



23710 State Road 213 N., Noblesville, IN 46060 U.S.A.  
 Phone: 1-800-CRAFTEC (272-3832) or local 317-984-4606  
 Fax: 317-984-5417

Top to Topless in 20 Seconds  
 www.craftecinc.com

## VINYL TONNEAU COVER ASSEMBLY INSTRUCTIONS

**BEFORE STARTING ASSEMBLY PLEASE READ THROUGH THE DIRECTIONS!**

There are variations noted for GM Sportside, Ford Flareside and Ranger Splash models.

**ANY BEDLINERS MUST BE UNDER THE RAIL MODELS. IF LINER GOES OVER FRONT RAIL, THIS MUST BE TRIMMED SO THE HINGE IS INSTALLED ON THE STEEL PORTION OF THE FRONT RAIL.**

### TOOLS REQUIRED

- 1/2" Wrench or Socket Set
- 7/16" Wrench
- Measuring Tape

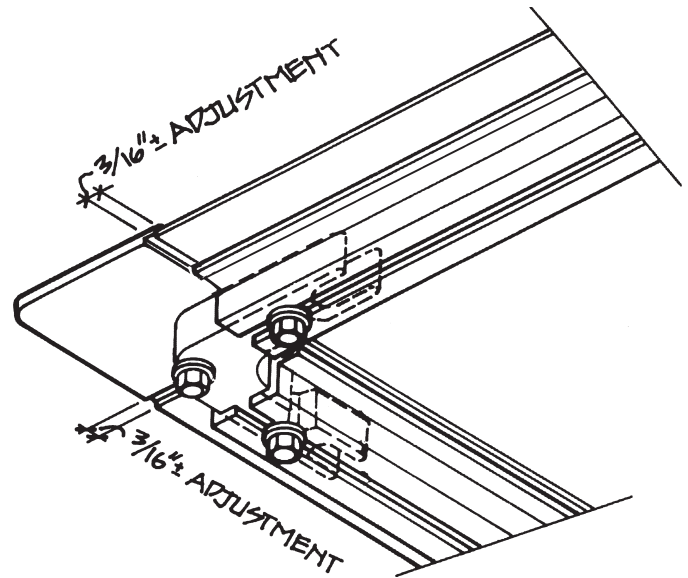

Soft top adjustment  
 Fig. 1

This cover is adjustable for the width and length to compensate for weather extremes. If the cover is too loose, the framework can be made longer and/or wider by loosening the corner bolts and moving the rails out on the corner brackets. This should be done equally on each side to keep the cover centered in the truck bed. EXAMPLE: 1/8" on the right side and 1/8" on the left side. **See Figure 1.**

**This cover's ultra low profile is designed so the majority of the frame work sits inside of box. Only 3/4" of aluminum will sit on bed rails.**

**1.** Assemble rails No. 2 and No. 4 by sliding 4" x 3/4" aluminum splice half way into 3/4" square section of each rail. Place 6" splice brace over splice with short leg of brace to out side of the rail. Align bolt holes with holes in 4" splice. Secure to rail with 5/16" x 3/4" thread rolling bolts. **See Figure 2.** The stick on numbers should be close together at splice.

**2.** Assemble rail No. 3 and No. 5 in same manner as rail No. 2 and No. 4. **See Figure 2.**

**3.** Slide 1st Bow Receiver into rail No. 3. **NOTE 1:** The round part of bow receiver slides into the round portion of rail. To ease installation of bow receiver into round slot of side rail, first lubricate round slot. Square nut slides into 3/4 x 3/4 square part of rail. **DO NOT TIGHTEN.** Next slide cover Shock Mount Clamp into 3/4 x 3/4 square part of rail, making sure ball part of stud

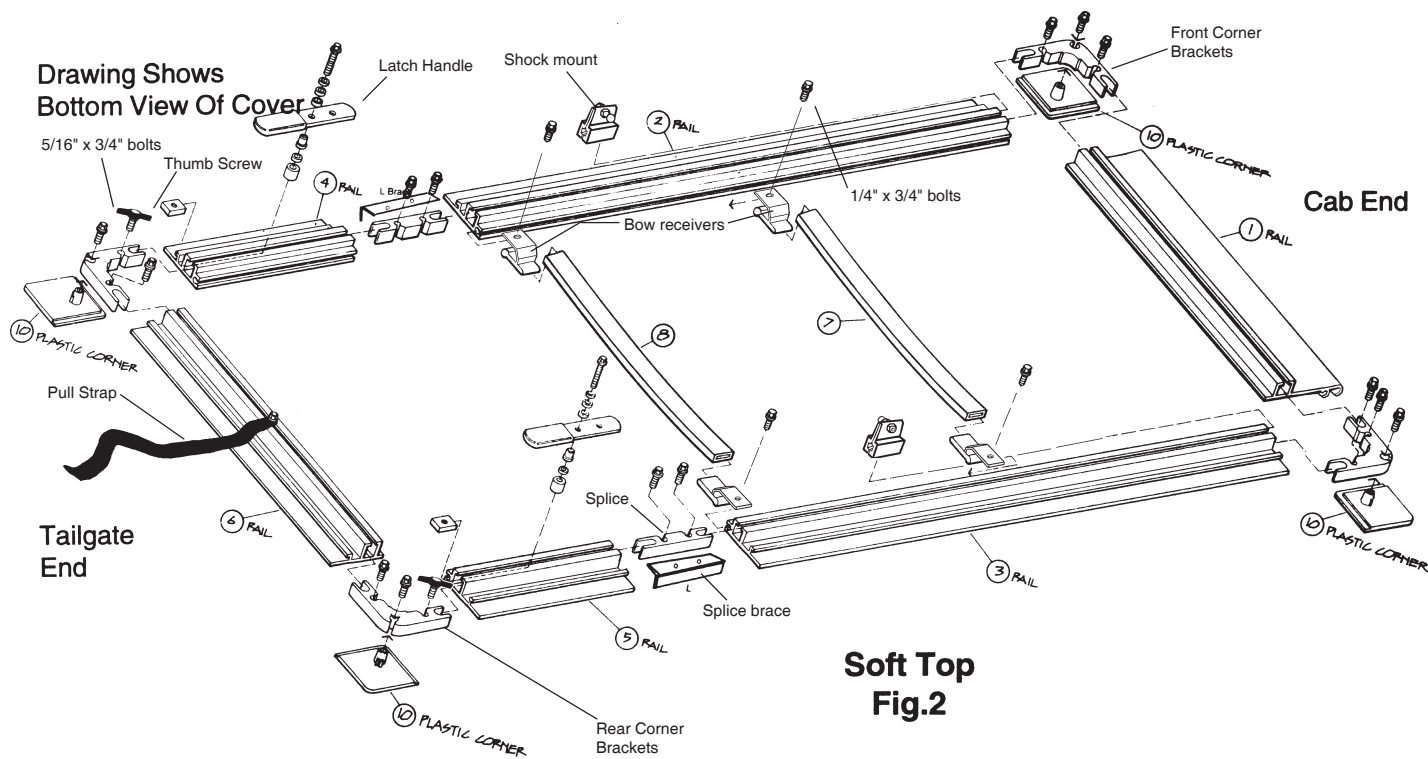

points to the inside of rail. **See Fig. 8.** Next slide 2nd Bow Receiver into rail the same way as 1st Bow Receiver. When Bow Receivers are installed in the rail, space them equally along the rail and tighten. **NOTE 2:** If the cover has 3 bows, a 3rd Bow Receiver will be placed in rail No. 4 and No. 5 in the same way as the others were. **See Figure 2 and Figure 8.** **NOTE 3:** 97 and up Ford Flareside, the side rails are the same length. Install splice into rails with rail numbers next to each other. The side rails will have a slight bow when assembled. The shock mount is placed into rails 2 and 3 first then one bow receiver. The other bow receiver is placed in rail 4 and 5 and then spaced evenly along rails.

4. Repeat process for rail No. 2 and rail No. 4.
5. Slide latch handle into 3/4" square portion of rails No. 4 and No. 5 and snug down to keep it from moving. Final adjustment will be made later. **See Figure 2 and Figure 10.**
6. Install rail No. 1 into rails No. 2 & 3 using 90½ 3/4" square aluminum corner brackets, and secure with 5/16" x 3/4" thread rolling bolts. **See Figure 2.** **NOTE:** These are the corner brackets without the thumb screws.
7. Slide bows onto Bow Receivers **NOTE:** Bows are numbered, lower numbers are placed at the front (cab end) higher numbers to the rear (tailgate end). **See Figure 2.**

8. Install Pull Strap and center in rear rail No. 6. Secure with 5/16" x 3/4" bolt and square nut provided. Install 90½ corner brackets marked rear into rail 6, using 5/16" x 3/4" thread rolling bolts. Install 90½ corner brackets into rails 4 & 5 and secure with thumb screws. **See Figure 2.**

9. Install "C" portion of hinge rail #11 into "C" portion of rail No. 1. **See Figure 7A.** **DO NOT** remove paper backing from tape at this time.

10. Trial fit frame work to the truck bed. Center the cover from side-to-side. Mark the location of the hinge rail No. 11 on the front of the truck bed. **NOTE:** An extra person is helpful to do this.

11. Remove cover from the truck. Remove hinge rail No. 11 from rail No. 1.

12. Locate 1/4" x 3/4" aluminum "L" brackets. Slide 4" portion of bracket into the 1/4" x 3/4" slot on both ends of hinge rail No. 11. **See Figure 4.** A piece of tape to hold these brackets in place may prove helpful at this time.

13. Clean front of bed with alcohol swab provided to remove all grease and wax. Check front bed rail for straightness, and correct if necessary. Remove backing from tape on hinge rail No. 11 and using marks found in Step 12, place hinge rail in position, pressing firmly to bond tape to bed front rail. Use additional clean rag and rubbing alcohol only if necessary to clean front rail.

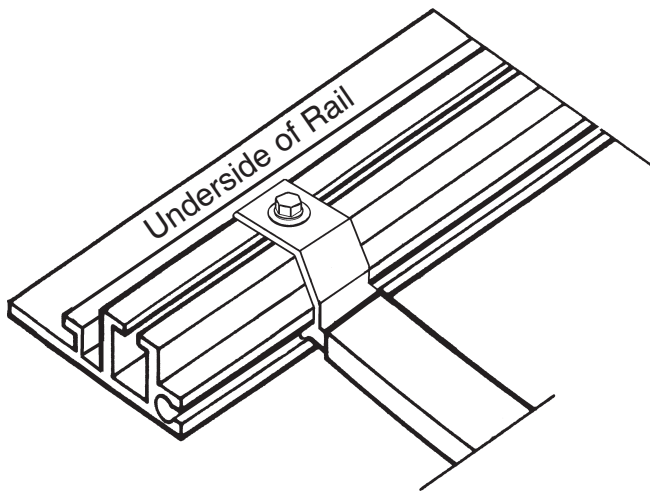

**Fig.3**  
Installing bow receiver

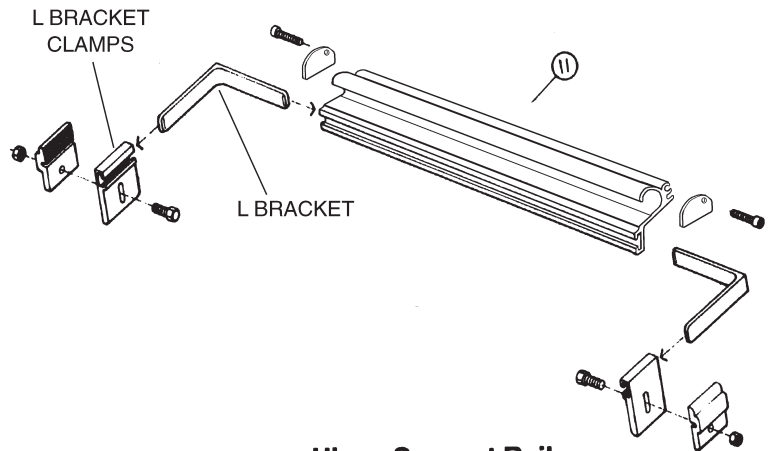

**Hinge Support Rail**  
**Fig.4**

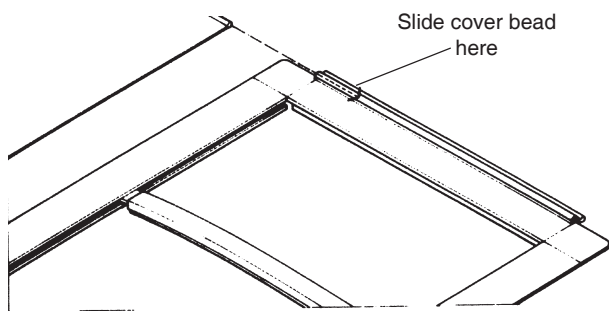

**Sliding Soft Cover In To Front Rail**  
**Fig.5**

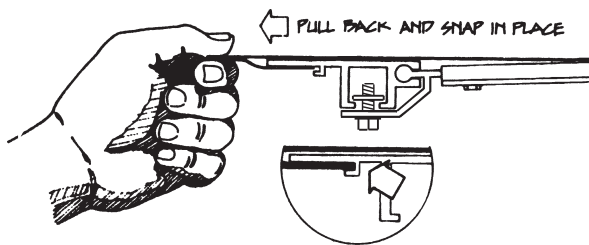

**Fig.6**

**14.** Slide "L" bracket clamps on to rear legs of "L" brackets. Adjust clamp under edge of the side of the truck bed and tighten. **See Figure 4.** **Note:** "L" Brackets should be parallel with the top of bed side and fully engaged into L Bracket clamp.

**NOTE #1:** 1988-1998 GM Sportside: Have special "L" bracket clamps that are provided and are bolted into the first inside fender bolt.

**NOTE #2:** 92-96 Ford Flareside: a 5/16" hole must be drilled 2" down from top rail and approximately 3" back from front of bed to mount

"L" bracket clamp. Secure with 5/16" x 1" carriage bolt provided.

**15.** Install plastic corners on each corner of the framework. **NOTE:** The notched corners go to the front of the framework. Secure this with 5/16" x 3/4" threaded rolling bolts provided. **See Figure 2.**

**16.** Next slide vinyl cover into the slot provide on rail No. 1. **See Figure 5.** **HELPFUL HINT:** A little liquid dish soap on the bead will make the vinyl slide easier. Once this is done, clip plastic over the edge of the sides and rear rail. Place the inner edge of the plastic strip between the small 3/16" lip and the under side of rail. If plastic does not fit into lip, adjust framework so that it does. **See Figure 1 and Figure 6.**

**17.** Install "D" shaped rubber weather seal on front plastic corners as shown in **Figure 11.** This seal is used to seal front corners of cover. If there is still a gap in the front, an additional seal may be applied to the truck bed to seal any gaps.

**18.** Position shock clamp on the edge of the bed and shock mount on cover at distance indicated in the chart and tighten. **See Figure 7 and Figure 9.** **Note:** Stroke shocks one or two times before installtion. **Big end of shock goes up.**

**NOTE #3:** GM Sportside: The ball stud is screwed into the 4th fender bolt from front of bed, on the inside of box. On 92-96 Ford Flareside and Ranger Splash you need to drill a hole for ball stud approximately 45" from front of box and down 2" from top of bed rail. Install ball stud and tighten.

## SHOCK MOUNTING CHART

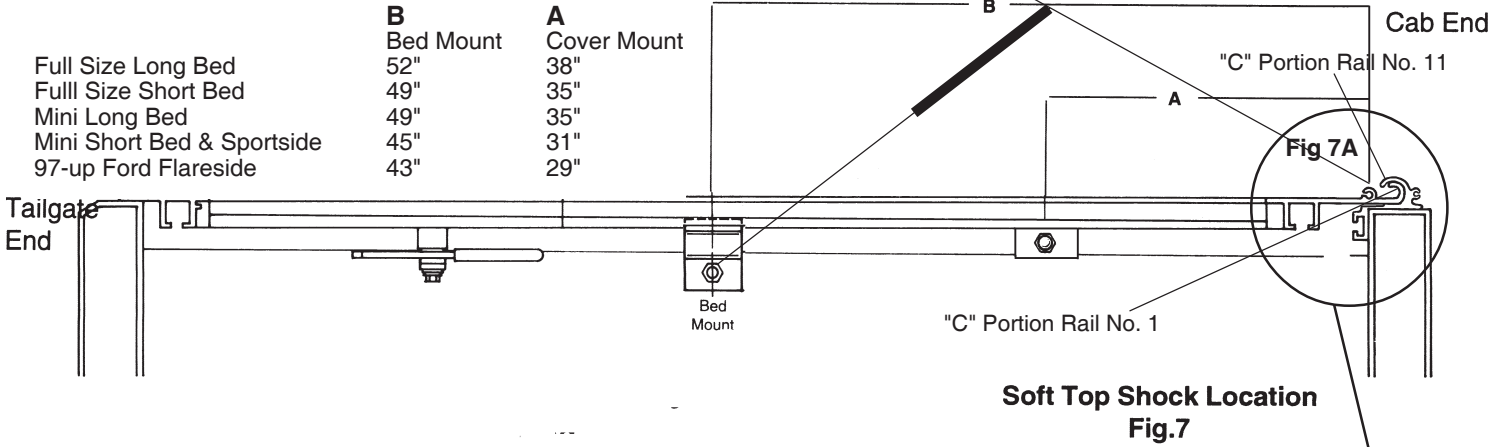

19. To install cover on truck hold cover up with rail No. 1 pointed down. Install "C" portion of rail No. 1 into "C" portion of rail No. 11, making sure "C" portion of both rails are fully seated from side-to-side. Lower cover slowly making sure there is no binding of the hinge. If binding occurs, raise cover back up and make sure hinge is seating properly. **See Figure 7A and 7B.**

20. Position latch handle so that there is no interference when turned under edge of bed rail. If height adjustment is needed, you may change location of plastic washers handle bolt. **See Figure 10.**

21. To remove complete cover from truck simply remove shocks from ball studs, tip cover straight up and pull back to disengage cover "C" channel from hinge "C" channel. Reinstall in reverse manner.

**NOTE:** To ease removal of shocks, place a small blade screw driver under "U" clip on shock end and pry up about 1/8" and pull shock off ball stud. You DO NOT need to remove "U" clip to remove shock from ball stud.

**NOTE:** To ease removal of bows, peel cover off framework, remove rear rail #6, push side rails apart and remove bow, reassemble in reverse order.

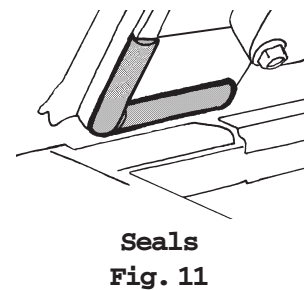
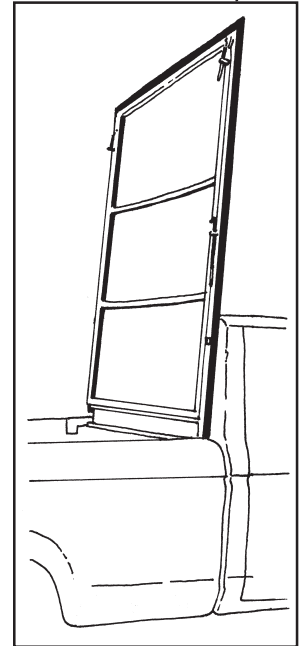
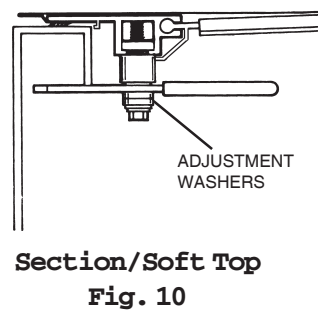
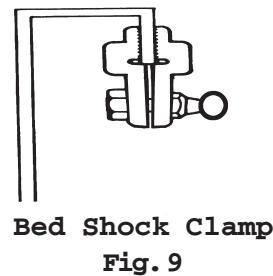
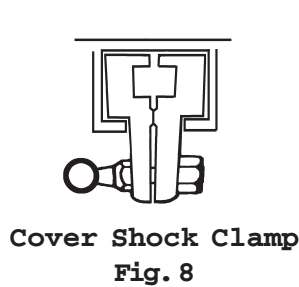

## IMPORTANT CARE INSTRUCTIONS:

### FAILURE TO FOLLOW THESE CARE INSTRUCTIONS WILL VOID WARRANTY

- Clean with soap and water **ONLY!**
- **WARNING:** Do not use any vinyl conditioners. They can damage the vinyl. Give clear instructions to any cleaning service not to use vinyl conditioners.
- **INSTALLERS:** Make sure customers receive these care instructions.