



SEN-06-1
 Fuel Level Sender
 (10-180 ohm for tanks 6" – 23" deep)

The kit includes the following parts:

Fuel sender (10–180 ohm)

Float

Screws (10-32 x 1/2" (qty 5))

Gasket

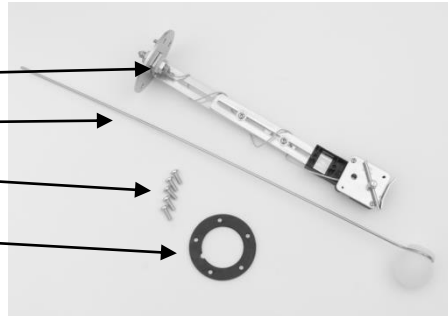

The SEN-06-1 is a 10-180 ohm fuel sender that can be adjusted to work with tanks ranging from 6"-23" deep. The sender has the standard SAE hole pattern and may work for most applications without drilling any additional holes. The steps below will guide you through sender installation and setup. Use care and take necessary precautions when working with a fuel tank that may have or have had some fuel in it. Double check all measurements and mounting spots before drilling or cutting.

Sender installation

First measure the depth of your tank and determine an appropriate mounting location.

When considering the mounting spot it is VERY important the float arm and ball are on the right side of the sender when looking at it from the front/pivot point. While the lower portion of the sensor can be rotated if necessary for clearance, making certain the float always sits on the right side of the pivot point will ensure correct readings; 10 ohms empty, 180 ohms full. Make sure there are no obstructions and that the float can move freely from full to empty and all the way through its range of motion.

Use the table and picture below to determine the critical lengths to help determine sender placement in the tank. From measuring the depth of your tank (dimension "A"), you can then locate the float arm pivot point from the top of the tank to the center of the float arm pivot (dimension "B"), and then find or determine the float arm length from center of pivot to center of the float ball (dimension "C").

Example: A 15" deep tank would require 7.5" from flange to pivot center, and float arm length 10" from pivot center to center of the float.

A	B	C	A	B	C	A	B	C
6	3	3.5	12.0	6.0	7.8	18.0	9.0	12.0
6.5	3.25	3.8	12.5	6.25	8.1	18.5	9.25	12.3
7.0	3.5	4.2	13.0	6.5	8.5	19.0	9.5	12.6
7.5	3.75	4.5	13.5	6.75	8.9	19.5	9.75	12.9
8	4	4.9	14.0	7.0	9.3	20.0	10.0	13.4
8.5	4.25	5.3	14.5	7.25	9.6	20.5	10.25	13.8
9.0	4.5	5.6	15.0	7.5	10.0	21.0	10.5	14.2
9.5	4.75	6.0	15.5	7.75	10.4	21.5	10.75	14.6
10.0	5.0	6.4	16.0	8.0	10.7	22.0	11.0	15.0
10.5	5.25	6.7	16.5	8.25	11.0	22.5	11.25	15.4
11.0	5.5	7.1	17.0	8.5	11.4	23.0	11.5	15.7
11.5	5.75	7.4	17.5	8.75	11.8			

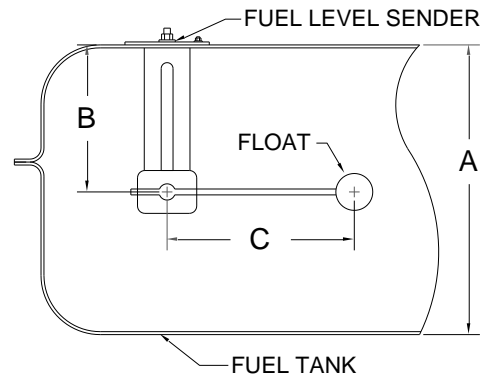

Preparing the sender hardware

For tanks from 6" - 15-1/2" an extension bracket will need to be removed from the sender. The procedure is:

- Remove two extension bracket screws and nuts
- Remove two sensor mounting screws (threaded into the plastic body)
- Remove the extension bracket
- Slide sender (plastic body) onto remaining bracket/arm
- Loosely install the two sensor mounting screws (into the plastic body)
- Slide sender up or down to the proper dimension from the table on previous page and tighten the screws



For tanks 16" to 23" no modifications or removal of brackets are required, just adjustments to the lengths. To adjust length:

- Loosen the two nuts and screws on the extension bracket
- Adjust lengths to the dimensions in the table on the previous page
- Tighten screws to secure parts in place

Installing the float arm

Before installing the float, this is the easiest point to install the gasket or ensure it is in the correct spot, so slide the gasket over the sender and up the bracket to the bottom of the flange so it is in position.

Loosen the screw at the pivot and discard the short piece of rod that is there. Insert the float rod to the proper length from the table above and tighten the screw to hold it in place. Use a side cutter or similar tool to trim the excess rod length, leaving about 1" past the pivot. ***Make sure float is on the right side of the pivot point or resistance values will be reversed and the gauge will read backwards.***



Installing in tank

If no holes exist in the fuel tank, you will have to cut a 1.7" hole in the top of the tank. You will also need to drill and tap holes for the mounting screws. Some fabrication may be required if it is a thin walled tank to provide enough material to facilitate mounting.

Install the gasket over the sender and up to the flange. Next slide the float arm and sender assembly through the hole in the tank. Align the bolt holes and secure the flange to the tank with appropriate hardware.

Note: you may want to test the sender with the gauge before installing into the tank.

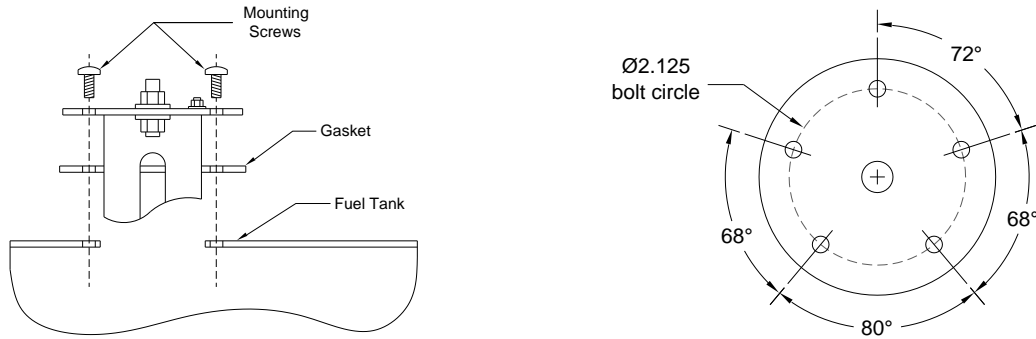

Wiring

The sender has two terminals on the top. The main, center connection is the resistance value that will connect to the fuel gauge. The smaller terminal off to the edge is the ground point. It is very important to have a good ground or the sensor will read erratically and the gauge will be incorrect. It is recommended to run a ground wire along with the sender wire and ground it at the gauge along with the fuel gauge ground.

You will also need to verify that the gauge can accept, or is set, to read a 10-180 ohm sender.

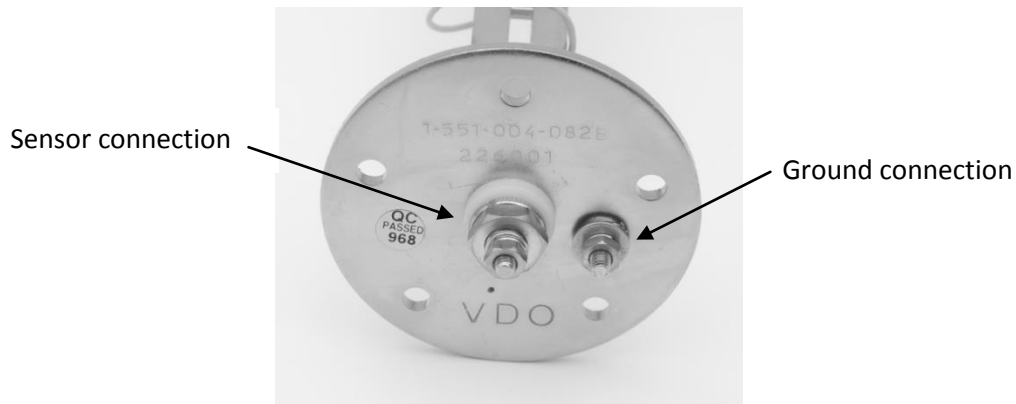

Troubleshooting

The sensor is a 10-180 ohm fuel sender. To verify sender resistance, disconnect the sender wire from the gauge and attach an ohmmeter to the sender wire and the other lead of the ohm meter to ground, or the ground point on the sensor. At empty with the float all the way down you should get about 10 ohms, with the float all the way up you should see about 180 ohms.

If the gauge is reading incorrectly double check connections and insure a good ground connection as well.

If readings seem off, double check the measurements performed during sensor installation.

Most fuel gauges have some averaging and may take some time to update the reading so be patient while testing. This is normal to avoid erratic readings with fuel "sloshing" in the tank.

If gauge reads backwards check and make sure the float arm is on the correct side of the pivot.

SERVICE AND REPAIR

DAKOTA DIGITAL offers complete service and repair of its product line. In addition, technical consultation is available to help you work through any questions or problems you may be having installing one of our products. Please read through the Troubleshooting Guide. There, you will find the solution to most problems.

Should you ever need to send the unit back for repairs, please call our technical support line, (605) 332-6513, to request a Return Merchandise Authorization number. Package the product in a good quality box along with plenty of packing material. Ship the product by UPS or insured Parcel Post. Be sure to include the RMA number on the package, and include a complete description of the problem with RMA number, your full name and address (street address preferred), and a telephone number where you can be reached during the day. Any returns for warranty work must include a copy of the dated sales receipt from your place of purchase. Send no money. We will bill you after repair.

Dakota Digital 24 Month Warranty

DAKOTA DIGITAL warrants to the ORIGINAL PURCHASER of this product that should it, under normal use and condition, be proven defective in material or workmanship within 24 MONTHS FROM THE DATE OF PURCHASE, such defect(s) will be repaired or replaced at Dakota Digital's option.

This warranty does not cover nor extend to damage to the vehicle's systems, and does not cover removal or reinstallation of the product. This Warranty does not apply to any product or part thereof which in the opinion of the Company has been damaged through alteration, improper installation, mishandling, misuse, neglect, or accident.

This Warranty is in lieu of all other expressed warranties or liabilities. Any implied warranties, including any implied warranty of merchantability, shall be limited to the duration of this written warranty. Any action for breach of any warranty hereunder, including any implied warranty of merchantability, must be brought within a period of 24 months from date of original purchase. No person or representative is authorized to assume, for Dakota Digital, any liability other than expressed herein in connection with the sale of this product.

⚠ WARNING: This product can expose you to chemicals including lead, which is known to the State of California to cause cancer and birth defects or other reproductive harm. For more information go to www.P65Warnings.ca.gov



4510 W. 61st St. North
Sioux Falls, SD 57107
www.dakotadigital.com

dakotasupport@dakotadigital.com Copyright 2011 - Dakota Digital, Inc.

Phone (605) 332-6513
Fax (605) 339-4106