



# G-Body Return-Less Style Fuel Plumbing Kit

Part Number: 526-23



Holley's GM G-Body Return-Less Style Fuel Plumbing Kit has the majority of parts and accessories for a complete plug and play fuel system kit. It includes everything to take the guesswork out and not only replaces but upgrades the original fuel system. Giving you all the flexibility while still maintaining a clean and easy OEM-like install.

## **Features:**

- Comes with everything needed to go from the fuel tank to the engine bay
- Prepares your 1978-1988 GM G-Body for EFI
- Simplifies your fuel system as a direct replacement
- Pump gas and E85 compatible
- Utilizes as many of the factory existing holes with no drilling required
- Includes enough nylon braided hose to go from the tank to the fuel rail
- Contains: AN fittings, 350 LPH EFI Fuel Pump Module, GM Style Filter/Regulator
- New hardware and clamps
- Pre-calibrated fuel level sending unit works with factory fuel gauge
- Most complete solution for your G-Body

## Overview/Parts List:

### General Layout for GM G-Body Return-Less Style Fuel System

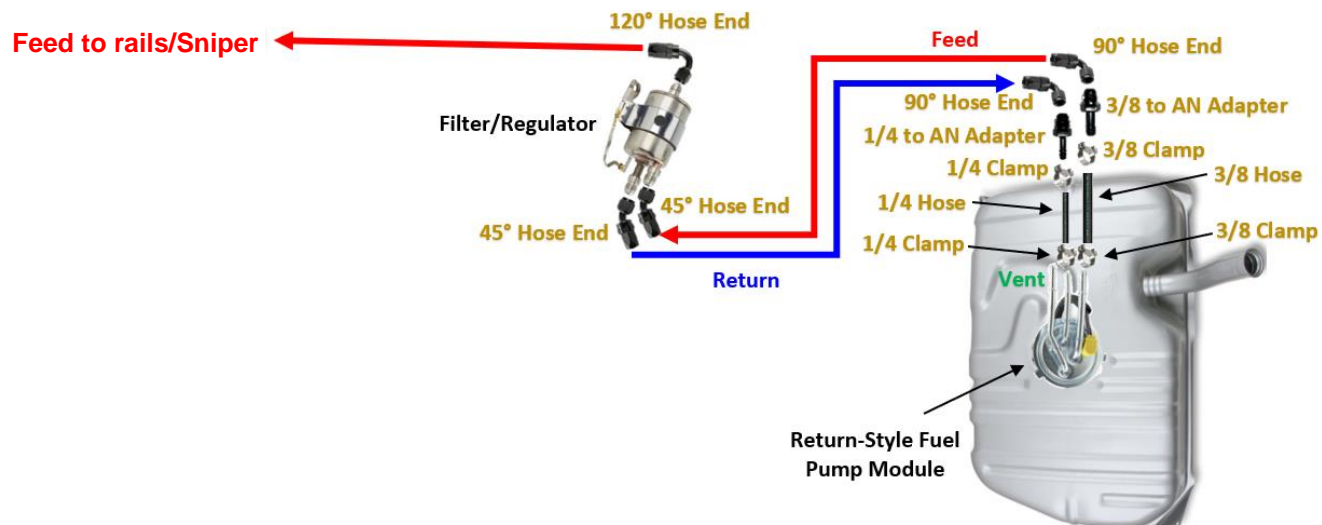

PICTURE	QTY.	DESCRIPTION	HOLLEY REPLACEMENT P/N
	1	Return-Style Fuel Pump Module 350 LPH	12-329
	1	Fuel Pump Module Pigtail	---
	2	3/8 Clamp	750006ERL
	1	3/8 Hose	750066ERL
	1	3/8 to AN Adapter	9002MRG
	2	1/4 Clamp	---
	1	1/4 Hose	---
	1	1/4 to AN Adapter	9000MRG
	3	90° Hose End	229006-BL
	3	45° Hose End	224506-BL
	1	Straight Hose End	220106-BL

	1	120° Hose End	231206-BL
	1	GM Style Filter/Regulator	162-591
	1	Nylon Braided Hose	842006
	5	5/8" P-Clamp	171010ERL
	5	Self-Tapping Frame Bolts	---
	1	1" Flame Guard	570010ERL
	1	Fuel Pump Relay Kit	40205G
	1	Split Wiring Loom	4505
	1	20 Amp Fuse and Fuse Holder	---

### **Recommended Parts to Connect the Fuel Injection System:**

**NOTE:** Some extra fittings are provided but depending on what type of engine is being used and how fuel is being delivered, additional fittings may be necessary to adapt to the fuel injection system such as for LS engines:

- **Earls O.E. Fuel Line EFI Quick Connect**

- -6 AN to 3/8" OEM Fuel Tube (FEED)
  - Part #: 751166ERL



## Installation Instructions:

### Read this manual before using this product.

**WARNING!** This instruction manual must be read and fully understood before beginning installation. If the instructions are not fully understood, installation should not be attempted. Failure to follow the instructions may result in subsequent system failure and could result in serious personal injury and/or property damage. Keep this manual.

For the safety and protection of you and others as well as your vehicle, only a trained mechanic having adequate fuel system experience should perform the installation, adjustment, and repair.

While undertaking any work involving the fuel system, it is particularly important to remember one of the very basic principles of safety: fuel vapors are heavier than air and tend to collect in low places where an explosive fuel/air mixture may be ignited by any spark or flame resulting in property damage, personal injury, and/or death. Extreme caution must be exercised to prevent spillage and thus eliminate the formation of such fuel vapors. All work involving this product and the fuel system generally **MUST** be performed in a well-ventilated area. Do **NOT** smoke or have an open flame present near gasoline vapors or an explosion may result.

Any components damaged due to failure to follow these instructions will not be covered by the warranty. Failure of any one component does not constitute, nor does it justify, warranty of the complete system. Individual service items are available for replacement of components.

Holley Performance Products cannot and will not be responsible for any alleged or actual engine or other damage, or other conditions resulting from misapplication of the fuel pumps and fuel pressure regulators described herein. However, it is our intent to provide the best possible products for our customer; products that perform properly and satisfy your expectations. Should you need information or parts assistance, please contact Technical Service at 1 (270) 781-9741, M-F, 8AM-6PM & Sat. 9AM-3PM CST. Please have the P/N ready when calling, thank you.

### Tools Required:

- 7mm Socket
- 1/2" Socket
- 13mm Socket
- 15mm Socket
- Ratchet
- 9" Extension
- Flat Head Screwdriver
- Rubber Mallet
- Masking Tape and Marker
- Pliers
- AN Wrenches (P/N: 230351ERL)
- Aluminum Vice Jaws (P/N: 1004ERL)
- Adjustable Wrenches
- Hose Cutting Shears
- Earl's Assembly Lube (P/N: 184004ERL)
- Fuel Container
- Jack and Stands



**NOTE: Due to manufacturers' discrepancies, use these instructions as a general guide as some things may differ from your certain application.**

### **1. Prepping the car**

- a.) Fuel tank will need to be removed, so have little to no gas in the tank.
- b.) If engine has been run within the past couple hours, let it cool down.
- c.) Clean surrounding areas around the fuel rail/fuel injection system so that no dirt can get into engine.
- d.) Ensure vehicle is parked on a flat, level surface.
- e.) Engage parking brake.
- f.) After relieving fuel pressure as mentioned below, remove negative (-) battery cable.
- g.) Safely lift and support the vehicle securely with jack stands, and wear appropriate eye and ear protection.

### **2. Relieving Fuel System Pressure**

- a.) **Ignition must be "off" and do not loosen any fuel system connections until relieving pressure as recommended in your automotive service manual.**
- b.) Relieving fuel pressure can be done in numerous ways depending on the fuel delivery system, here's some general ways:
  - i. **Throttle Body Injected Engines:** Remove fuel pump fuse from the fuse box, start the engine until it runs out of fuel and shuts off, continue by cranking engine over for 3 seconds to relieve any remaining fuel pressure, and lastly, turn ignition off and reinstall fuel pump fuse.
  - ii. **Port Injected Engines:** Disconnect the fuel tank harness connector, start the engine until it runs out of fuel and shuts off, continue by cranking engine over for 3 seconds to relieve any remaining fuel pressure, and lastly, turn ignition off and reconnect fuel tank harness connector.

### **3. Fuel Tank Removal**

- a.) Remove fuel cap behind rear license plate.
- b.) Disconnect Pink fuel sender wire connector and remove ground strap screw with **7mm socket**.

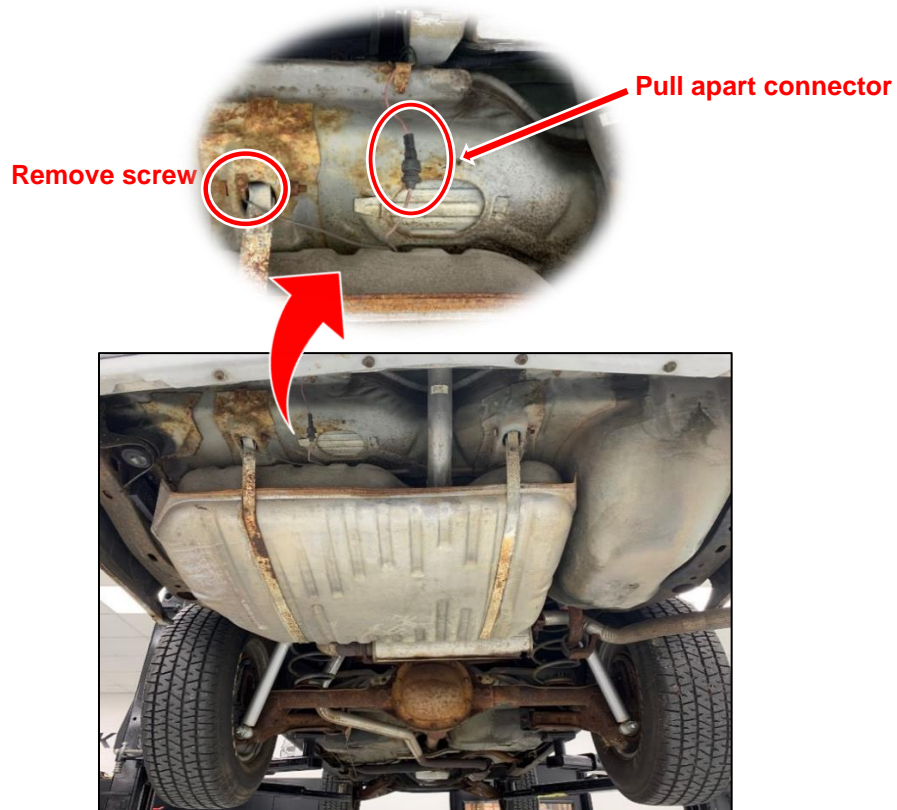

- c.) Remove fuel line clamp bolt with **1/2" socket** and disconnect all (x3) hoses by relieving clamps with **pliers**.

**NOTE:** Place fuel container underneath to prevent leakage onto floors.

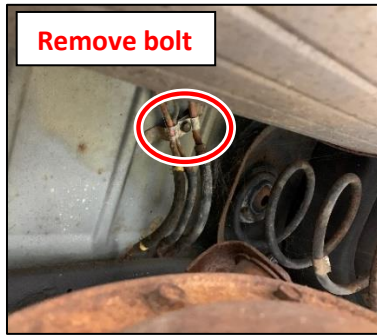

d.) Support fuel tank with a **jack** and use a **9" extension** with **15mm socket** to remove (x2) fuel tank strap bolts.

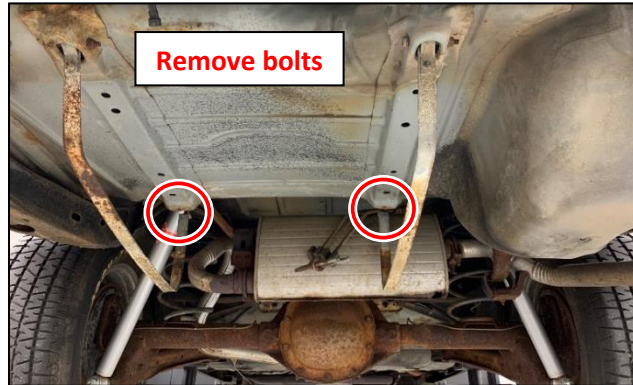

**NOTE:** Fuel Tank not shown for visual purposes.

e.) Slowly lower fuel tank and remove the 3 remaining clamps with **pliers** to detach hardlines to drop tank.



#### 4. Fuel Sender Removal

a.) Once tank is removed, clean surrounding areas around the fuel sender so that no dirt can get inside tank. With a **Flat Head screwdriver** and **Rubber mallet**, remove the lock ring by rotating it counter-clockwise.



## 5. Fuel Pump Module Install

a.) Lift up and remove the Fuel Sender as it will be replaced with an in-tank Fuel Pump Module.

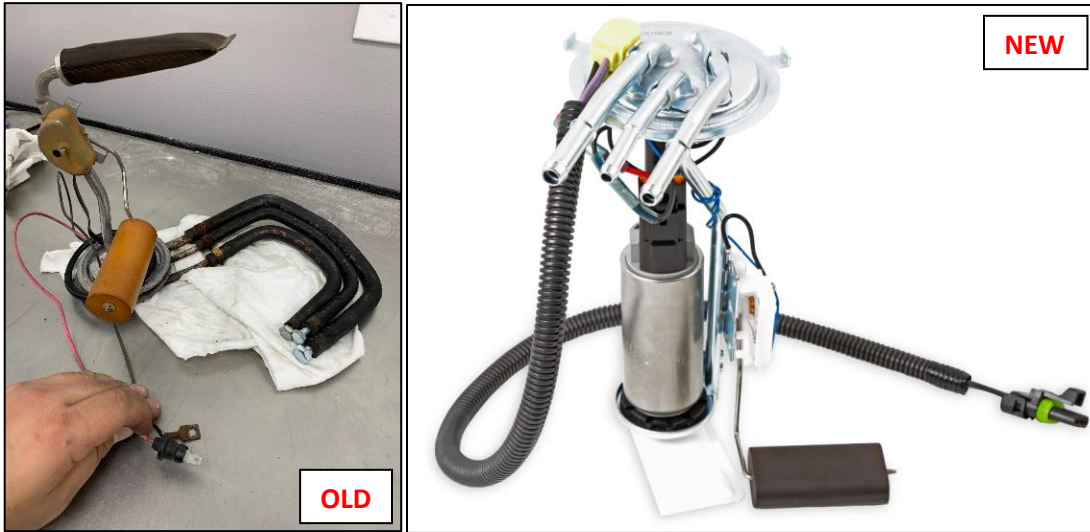

b.) OE Style Fuel Pump Module has Hose Barb inlets, so we will convert the 3/8" Feed and 1/4" Return to AN. Using the clamps, hose and the hose barb to AN adapter, tighten clamps with a **7mm socket**



**NOTE: Do the same for the 1/4 Return.**

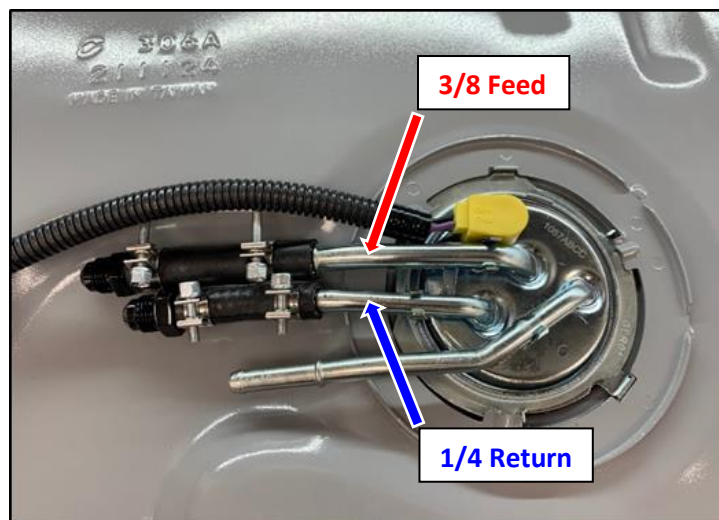

**NOTE:** For non-baffled fuel tanks, we recommend **Part #: 16-150**, 19mm Outlet Offset HydraMat, to greatly reduce the potential of air entering the fuel system and limit fuel starvation during hard cornering, braking acceleration, inclines, and low fuel conditions.

- c. If upgrading with the new 16-150 HydraMat, install HydraMat by aligning the “V” shape of the rubber grommet to arrow on the mat, press firmly to seat.

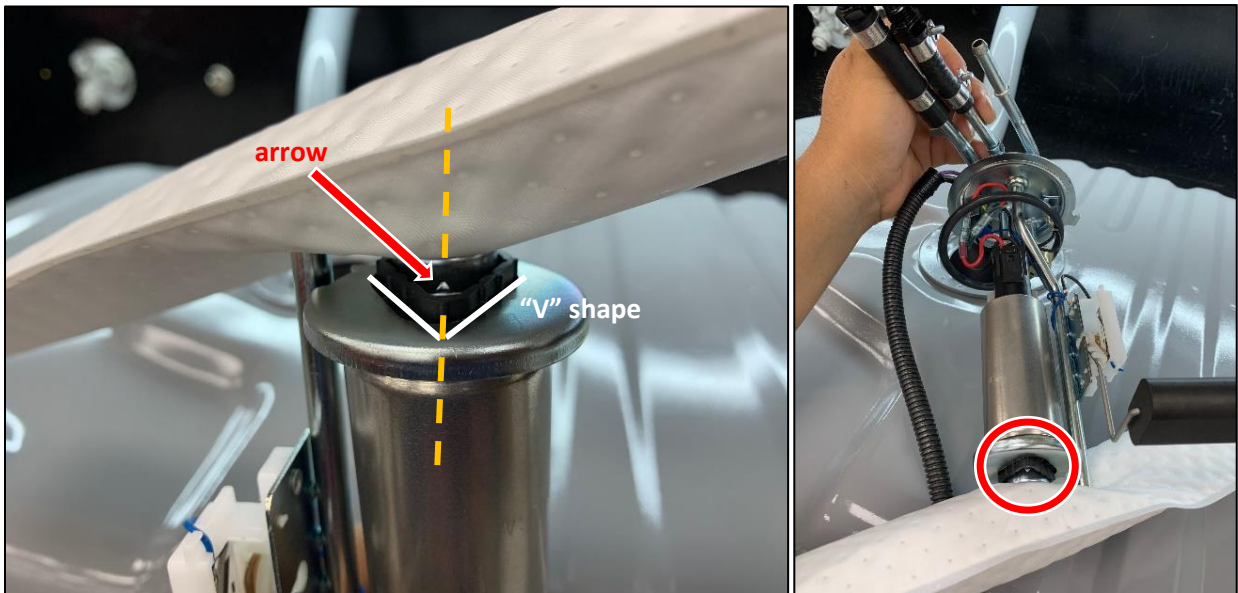

- d. If aligned properly, the HydraMat's short end points in the 10 o'clock position and the long end in the 4 o'clock orientation. This maximizes the effectiveness of the mat and allows the short end of the mat to be tucked underneath the internal wall inside the tank.

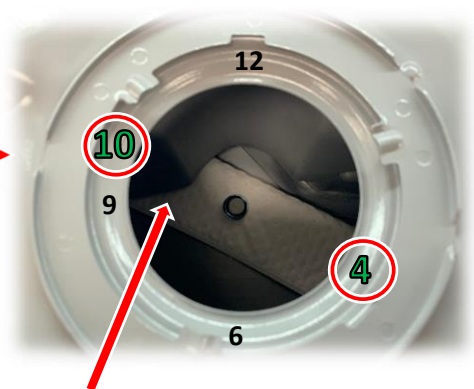
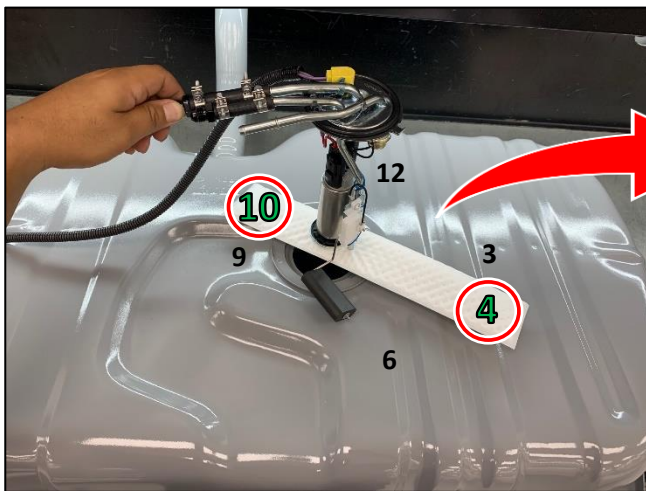

**Notice how the mat is tucked underneath**  
**NOTE: Pump not shown for visual purposes**



- e. Slide long end of the HydraMat first along with tucking in the fuel sender float arm into the hole entrance.  
**NOTE: Be cautious to not tear the HydraMat while inserting into tank.**

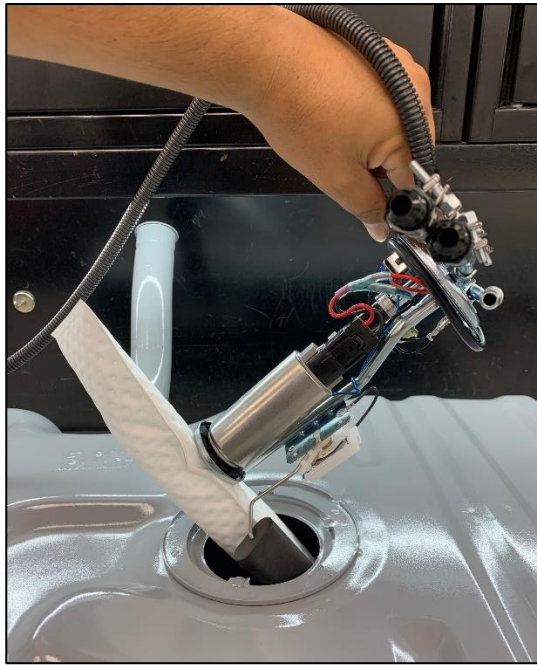

- f. Lubricate the lock ring's O-ring with **Earl's Assembly Lube**.

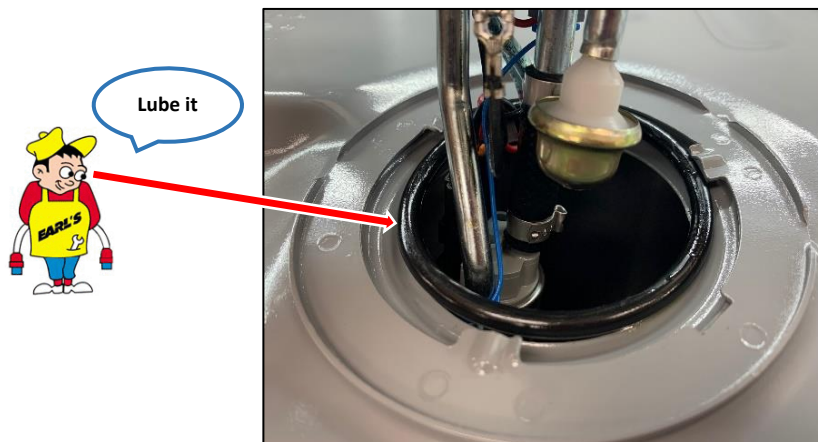

- g. Seat lock ring and secure by rotating it clockwise with a **Flat Head screwdriver** and **Rubber mallet**.



## 6. Factory Fuel Lines Removal

This kit replaces the factory fuel lines with Black Nylon Braided Hose. The factory fuel lines will need to be removed and new hardware and clamps are provided.

- a. Remove all bolts on passenger side frame rail that attach the fuel lines with a **1/2" socket**.

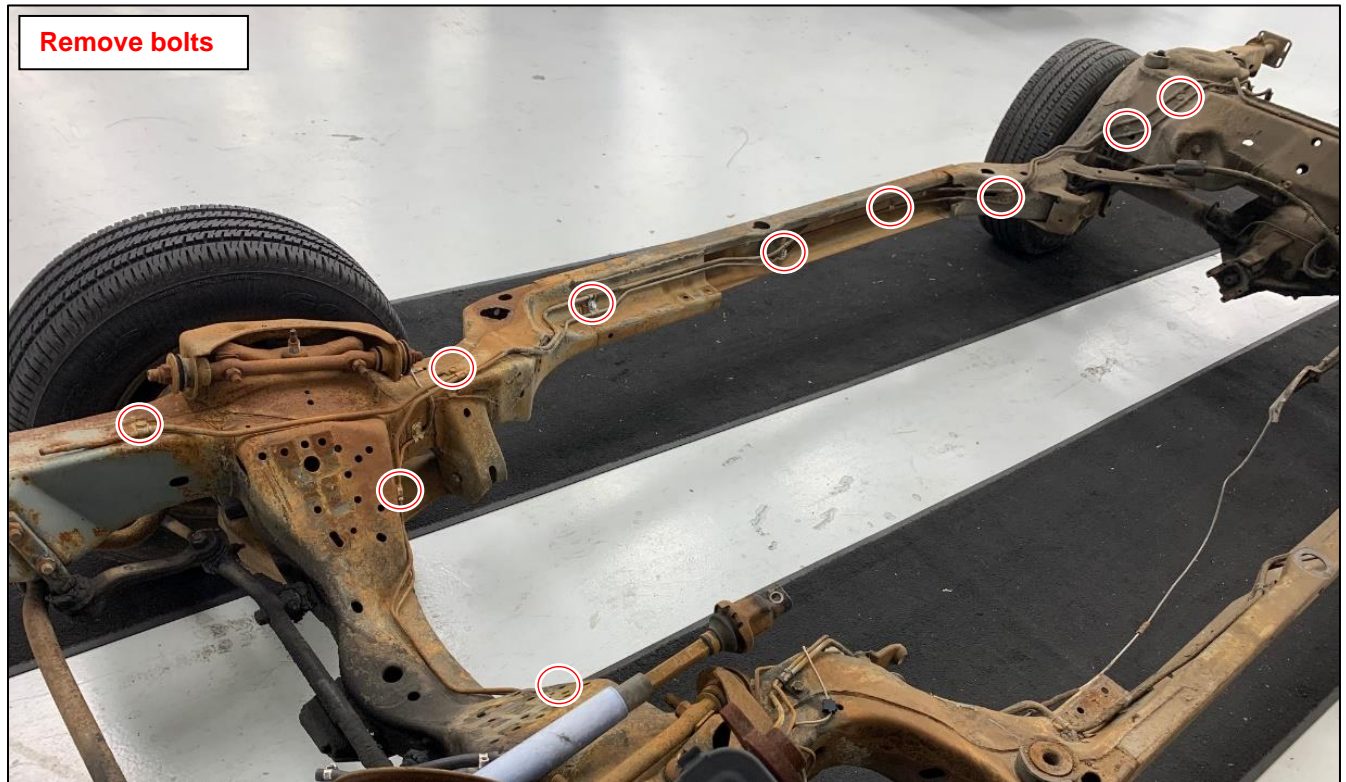

- b. Completely remove all bolts and factory feed and return lines.

**NOTE:** Due to age and condition variances, we noticed some frame bolts were rusted, so we provided new frame bolts that are self-tapping. They are not the same thread-pitch and will cut new threads, use as needed. If using, position screw straight, aligning with hole and turn 1-2 turns by hand. Use **13mm socket** to drive in new screw.



## 7. Mounting GM Style Filter/Regulator

- a. Note the locations of the ports to properly plumb the filter/regulator, where the long-extended fitting returns back to the fuel tank.



- b. Install 120° Hose End to "Feed to Engine" and two 45° Hose Ends on the other side where the long-extended fitting "Returns back to the tank" and the other is the "Feed from Pump".

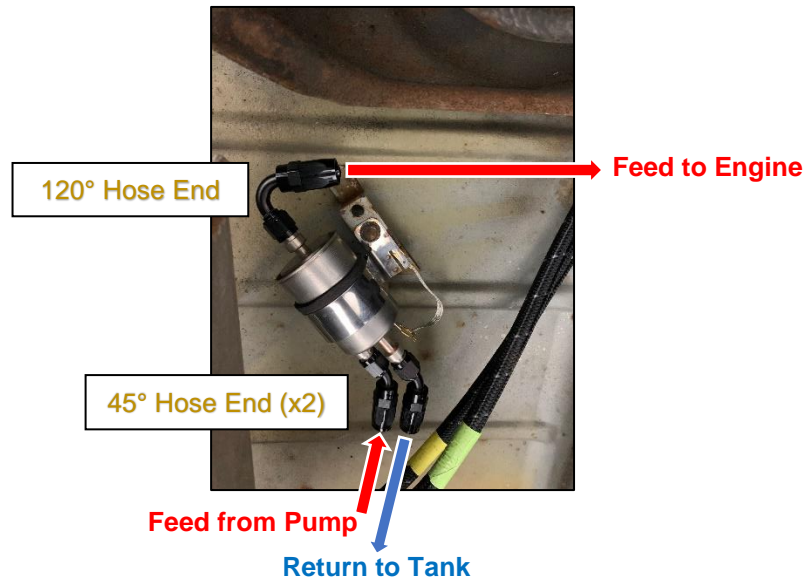

- c. Filter/Regulator's mounting tab mounts with existing fuel line tab and is in alignment with one another.

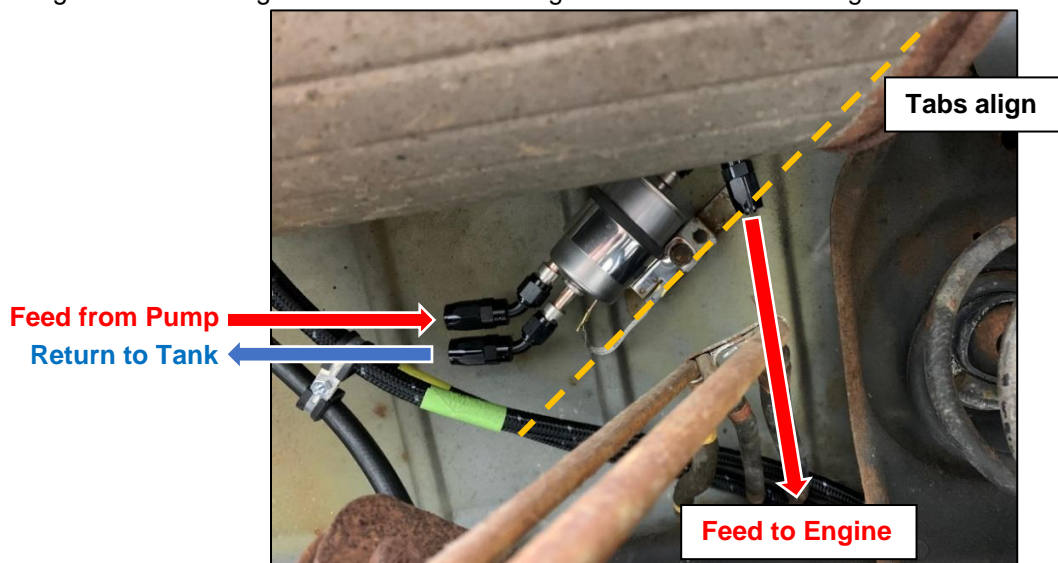

## 8. Assembling AN Hose

AN fittings and hose will replace the factory fuel lines, here we'll show a general way to assemble them:

- a. Cut the hose square to the required length with **Hose cutting shears** or equivalent.

 **TECH TIP:** Before cutting, wrap hose tightly with masking or electrical tape and cut through the tape. This helps prevent the braid from fraying and trim any frayed ends with cutting pliers.

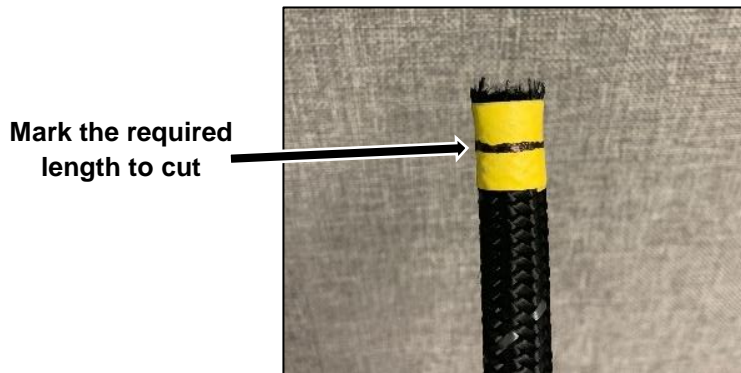

**Not Acceptable:** cut is not level, excessive fraying. Try again

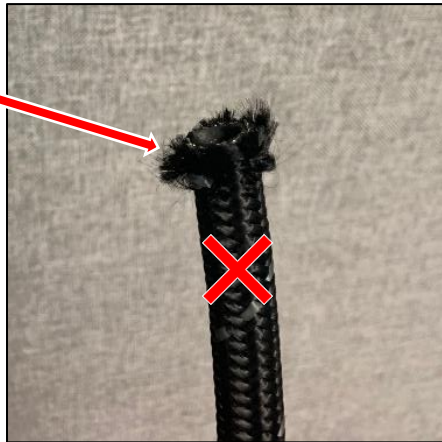

**Acceptable:** hose is cut square with little to no fraying

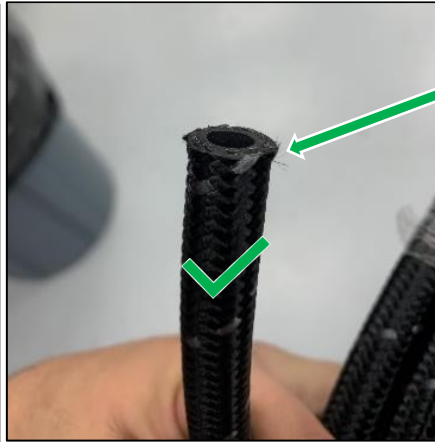

- b. Insert hose into socket by pushing and turning it clockwise until the hose butts against bottom of threads.

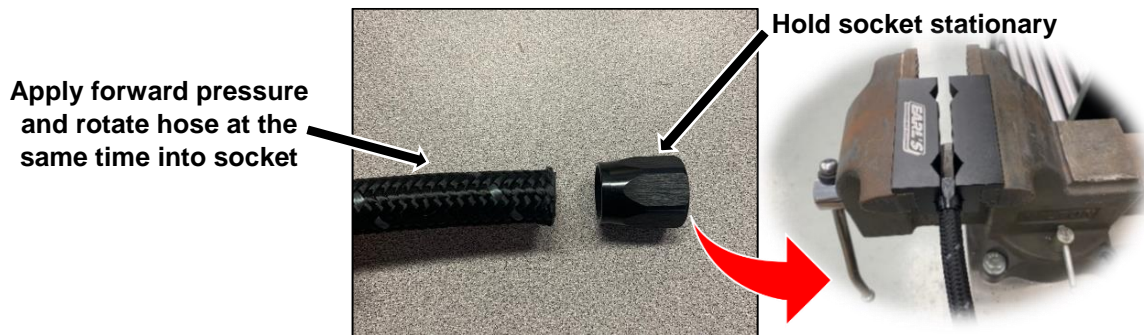

**Not Acceptable:** Keep pushing and twisting to remove gap



**Acceptable:** hose is bottomed out before threads

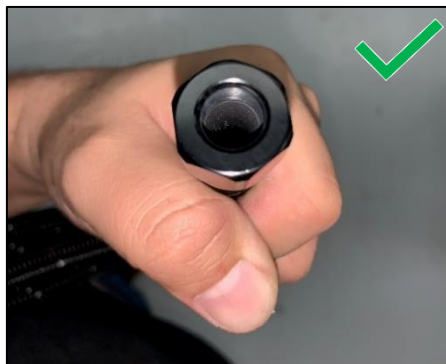

 **TECH TIP:** Wrap tape around hose right against bottom of socket, this will be your visual aid to detect any tendency of the hose to be pushed out as you complete the assembly.



c. Lubricate inside of the hose and the fitting's threads with **Earl's Assembly Lube**.

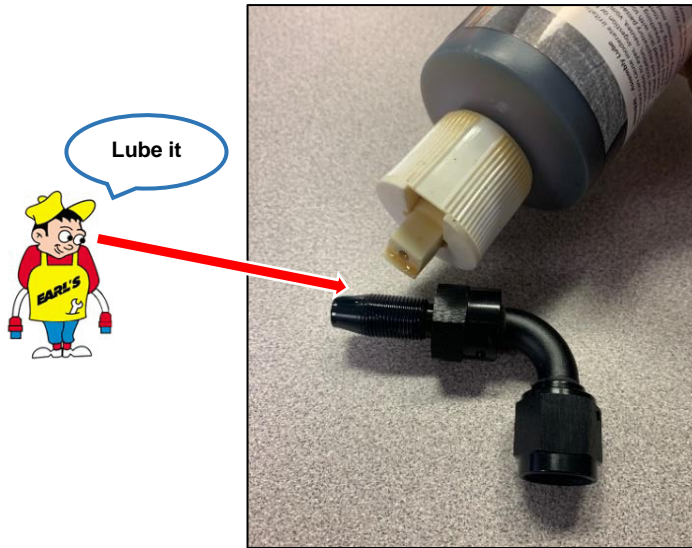

d. Holding the socket with **Aluminum Vise Jaws**, start the hose end by hand and then use **AN wrenches** or equivalent (tape on adjustable wrenches) to tighten the fitting assembly.

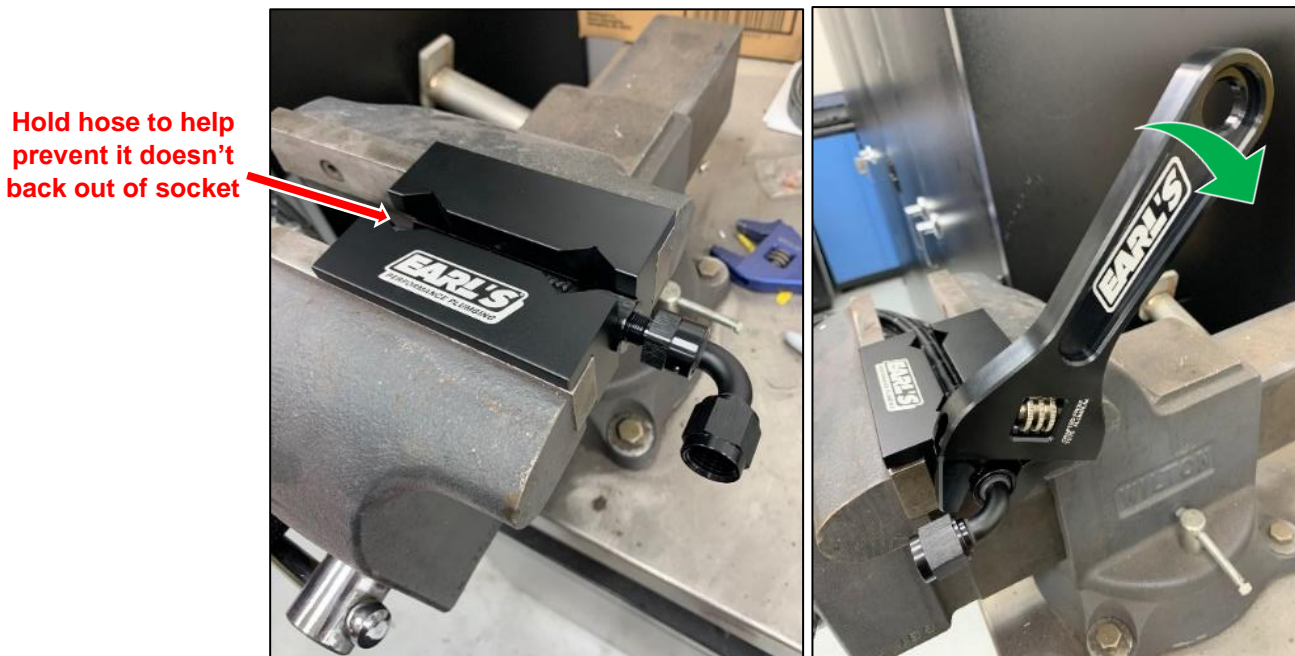



**TECH TIP:** Line up the flats on the hose end for that professional install while tightening, but don't loosen.

Tighten until socket must be within 0.060" or less of bottoming on the hose end.

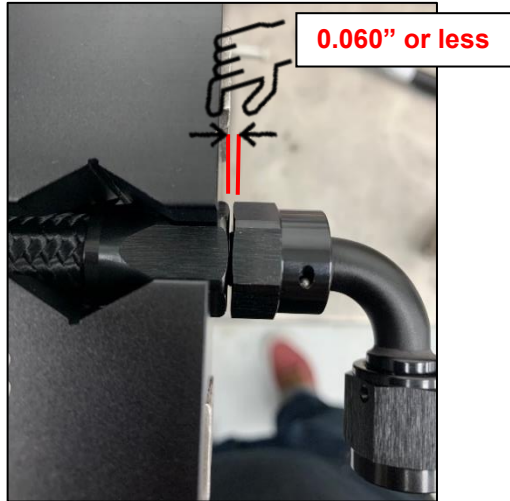

Check the tape to see if the hose end has pulled away from the hose, if it did back out more than ~1/16" out of the socket, try again by returning back to Step 12c.

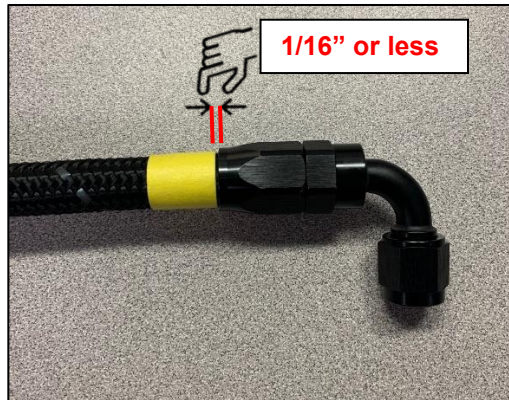

Remove the tape, and make sure your hose assembly is free of debris and thoroughly clean.



**NOTE:** Pressure test hose assembly to ensure no leaks. Further check the assembly by running the system at full pressure while you observe the hose, hose ends, and adapters for leaks.

**WARNING!** If metal cutoff wheel was used to cut hose, it is critical that you thoroughly clean the hose assembly and ensure it is free of any debris. Flushing the system prior to making the last connections to the fuel rails may be necessary to prevent any damage.

## 9. Routing Fuel Hoses

With factory fuel lines removed, route the new Feed and Return Black nylon braided hoses in the same location as the original lines. New 5/8" P-Clamps and Frame Bolts will be mounted using the same existing threaded hole locations. Thus, these will be a direct replacement and will keep the fuel hoses in the OE location.

- a. Using the General Layout in the Overview Section in Page 2 and the diagram below, route the new fuel hoses onto the frame with the supplied 5/8" P-Clamps and tighten frame bolts.

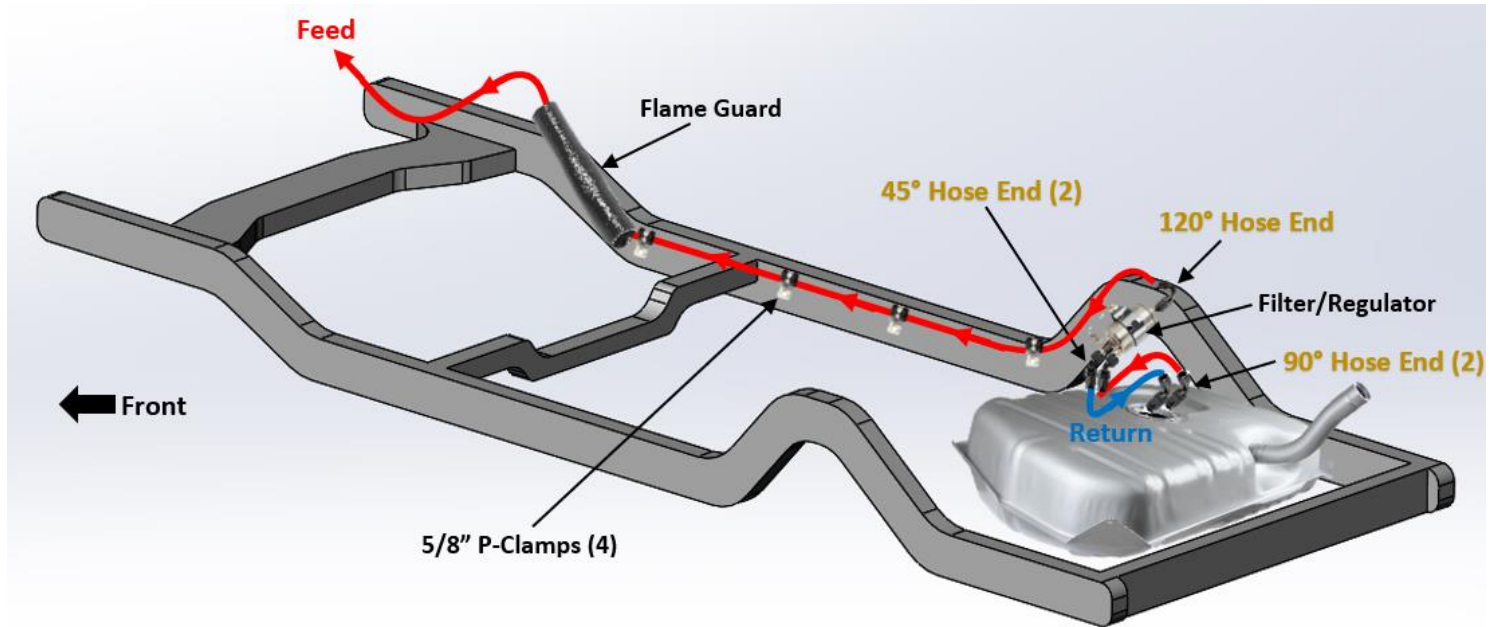

### A few guidelines to follow:

- Ensure the insulated clamps are snug on the fuel hose to avoid droop and abrasion
- Install Flame Guard over the feed hose near the exhaust manifold
- Be cautious to avoid suspension, lift and frame pinch points
- Keep hoses away from moving parts: axles, steering components, wheels, driveshaft, etc.
- Avoid heat sources: engine, exhaust, heater hoses, etc. which can cause vapor lock or worse, a fire
- Allow for bend radius, hose end length and offset to obtain length of hose required
- All fuel line connections must be leak proof

 **TECH TIP:** Label Feed and Return hoses to help distinguish which hose is which.



b. Reference the following photos to aid installation:

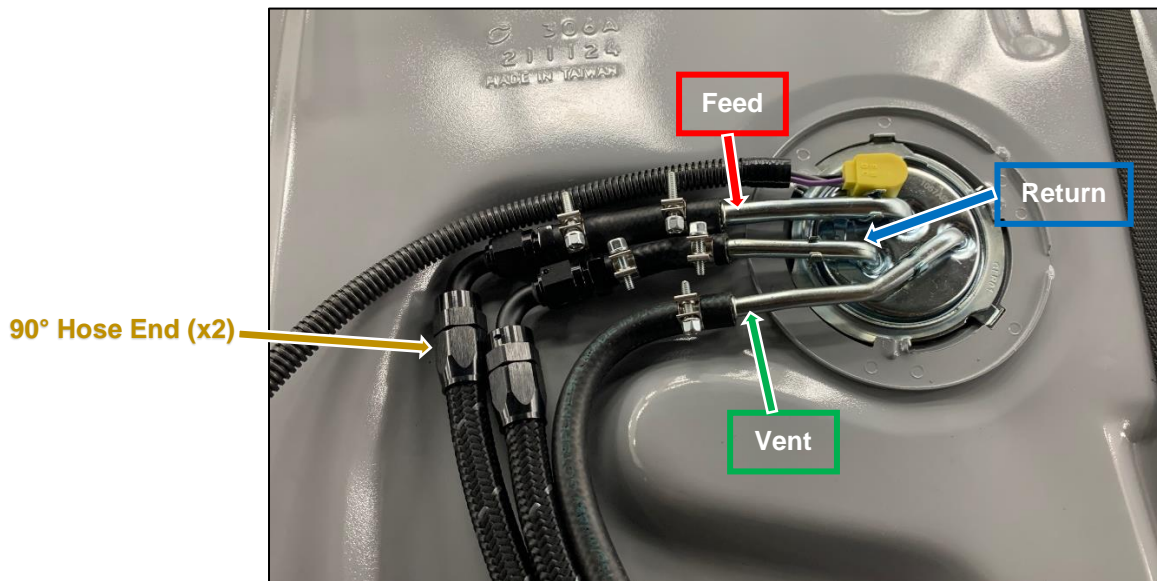
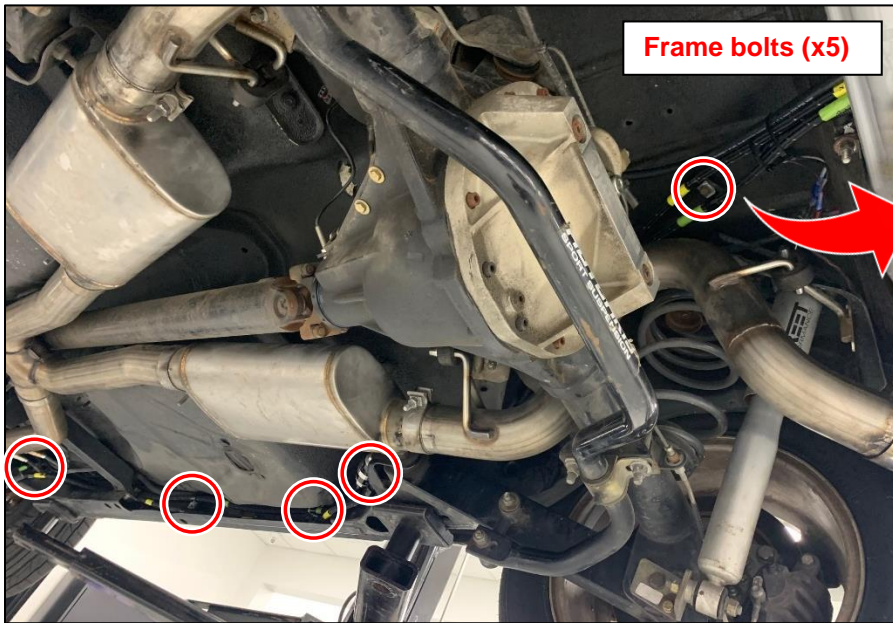
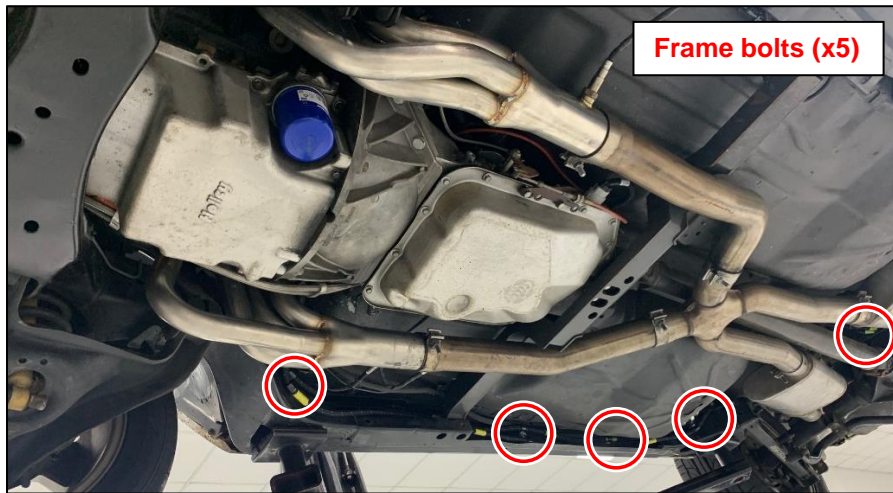

**NOTE:** The 5/16" vent hose can be replaced with 3 feet of **750055ERL** and clamps: **750005ERL** (not supplied).



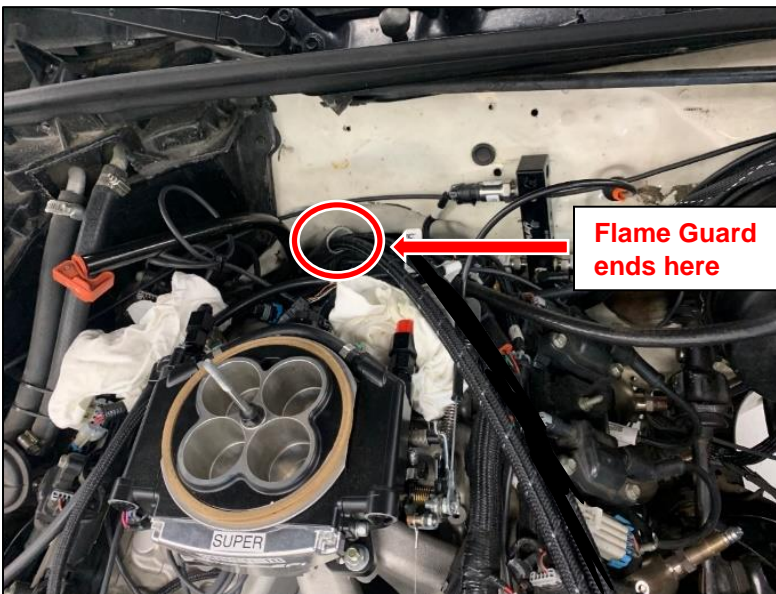
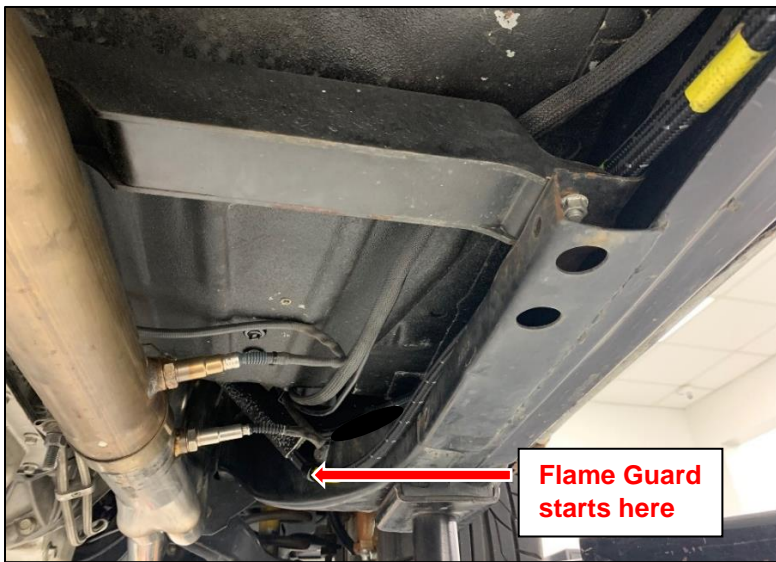
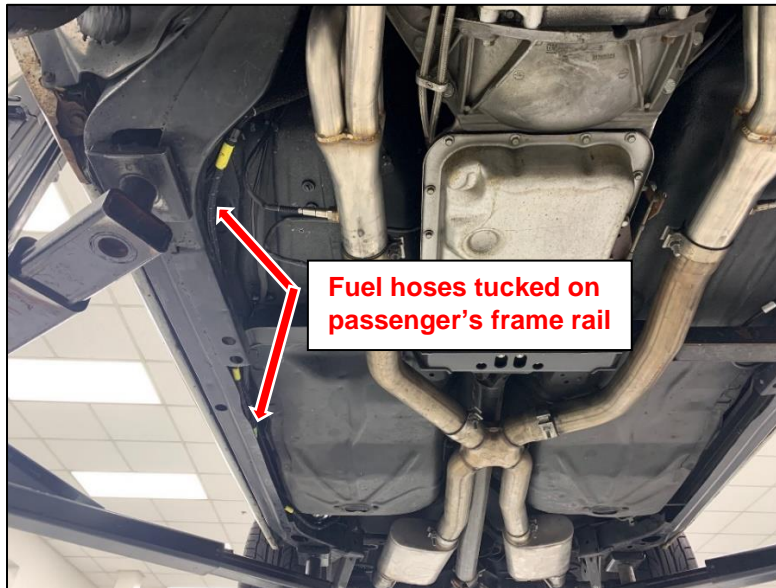

**NOTE:** Again, some extra fittings are provided but depending on what type of engine is being used and how fuel is being delivered, additional fittings may be necessary to adapt to the fuel injection system. Thus, we stopped at the engine bay to give as much flexibility to plumb the last connections onto the fuel rail.

## 14. Fuel Pump Wiring

Kit contains an Electric Fuel Pump Harness & Relay Wiring Kit. With couple modifications it can be a direct fit for your G-Body. A plug and play harness for the fuel pump module and an in-line fuse holder with the recommended 20 Amp fuse is included. Always crimp or solder connections and ensure surface is clean/grind where ground is connected. Cover it all up with the provided split wiring loom for that factory-look install and you're ready to go!

- a. Follow the wiring instructions supplied with Holley® P/N **40205G** and make the following modifications:

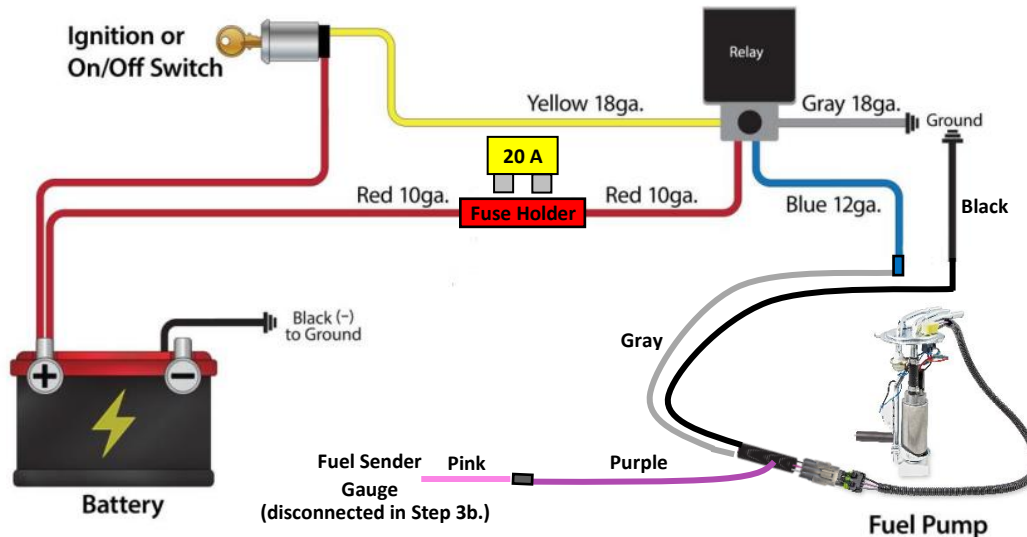

## 15. Inspect for Leaks

Confirm all plumbing and wiring of the fuel system assembly is complete, with enough fuel in the tank, reconnect battery, switch on the fuel pump but do NOT start the engine. Inspect all connections and components for leaks. If any leaks are found, immediately de-energize the system and repair the leak(s).

## 16. Tank Installation

Once all plumbing and wiring connections have been made, the tank installs in the reverse order of removal.

**WARNING! Any fuel that is spilled during any part of this installation must be immediately soaked up with shop towels/rags and removed from the vicinity of the vehicle.**

## 17. Final Inspection

When all leaks have been repaired and system is leak-free, cycle the key between the on-and-off positions a few times to build system pressure. At this point, ensure regulator is set to the desired pressure and adjust as necessary. Verify no leaks and then, start the engine, after running for a few minutes but before driving, check for any leaks. If all is good, congratulations, you did it and installation is complete! Enjoy some smiles per gallon!

**Holley® Performance Products, Inc.**  
1801 Russellville Road  
Bowling Green, KY 42101

Technical Support: 1-866-464-6553  
Phone: 1-270-781-9741  
[www.holley.com](http://www.holley.com)

© 2022 Holley Performance Products, Inc. All rights reserved. Tous Droits Réservés.

199R12458  
Date: 11-11-22