



Detroit Speed, Inc.
Rear Coilover Conversion Kit
2016+ Camaro
P/N: 042432, 042432-D

The Detroit Speed, Inc. 2016+ Camaro Rear Coilover Conversion Kit is a direct bolt-on assembly that completely replaces the OEM rear strut assembly. The kit uses a Detroit Speed/JRi all aluminum shock with "Detroit Tuned" valving. This kit includes helper springs and spring dividers if you choose to run a low ride height along with all necessary hardware. The kit allows ride height adjustment and easy rear spring changes.



Item	Description	Quantity
1	Upper Shock Mount Assembly, LH and RH	2
2	Coilover Shock	2
3	Coilover Spring	2
4	Helper Spring	2
5	Stacked Spring Divider	2
6	Lower Shock Tapered Spacer	4
7	Upper Shock Bushing	2
8	1/2"-20 x 2-1/2"L Socket Head Cap Screw	2
9	1/2"-20 Nylock Nut	2
10	1/2" AN Washer	2
11	Detroit Speed/JRi Spanner Tool	1
12	Torrington Bearing Set	1
13	Instructions	1

NOTES:

1. Since the Detroit Speed coilover kit replaces the magnetic ride control, you will need to purchase the X-inengineering Electronics GM shock simulator kit to keep the warning light off on the dash. Visit there site at www.xineering.com.
2. Detroit Speed recommends the Rear Coilover Tower Brace Kit (Detroit Speed P/N: 042433) when installing the Detroit Speed Rear Coilover Conversion Kit.

Installation Instructions:

1. With the vehicle safely up on jack stands, remove the rear wheels.
2. Remove the plastic lower control arm assembly covers from both sides of the vehicle by removing the push pins (Figure 1). **NOTE:** These will be re-installed so keep track of the left and right hand side cover.

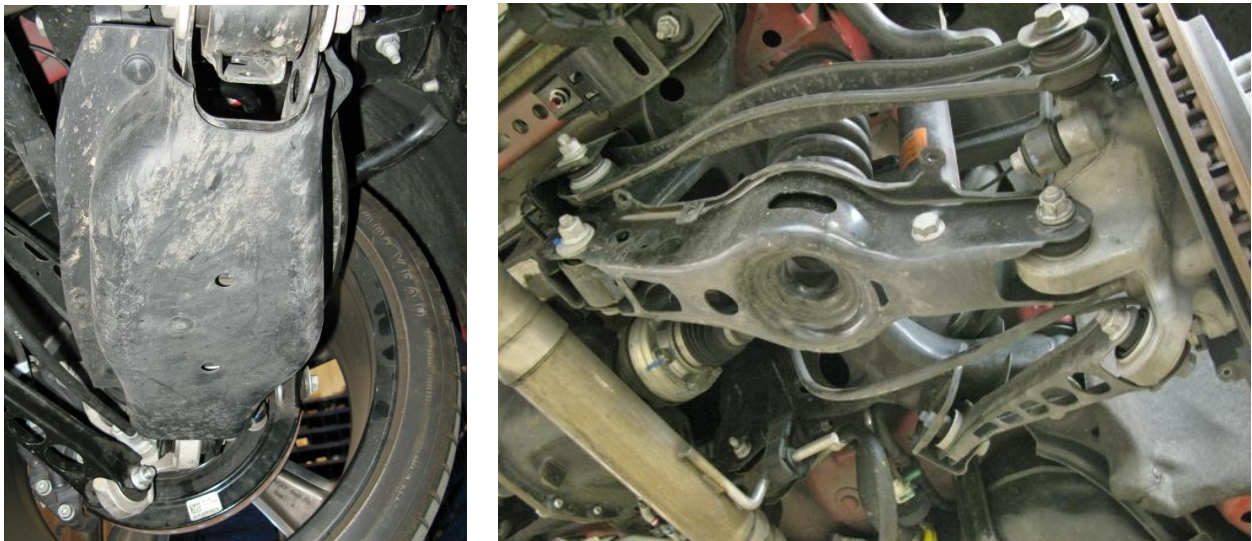

Figure 1 - Remove Lower Control Arm Covers

3. Disconnect the ride height sensor attached to both lower control arms (Figure 2). They should pry off the lower control arms and will be re-attached later.



Figure 2 - Disconnect Ride Height Sensor

4. Remove the retention bolt for the park brake cable from the rear upright on both sides of the vehicle (Figure 3). Loosen the park brake cables by pulling the cables out of the uprights. They do not need to come all the way out.

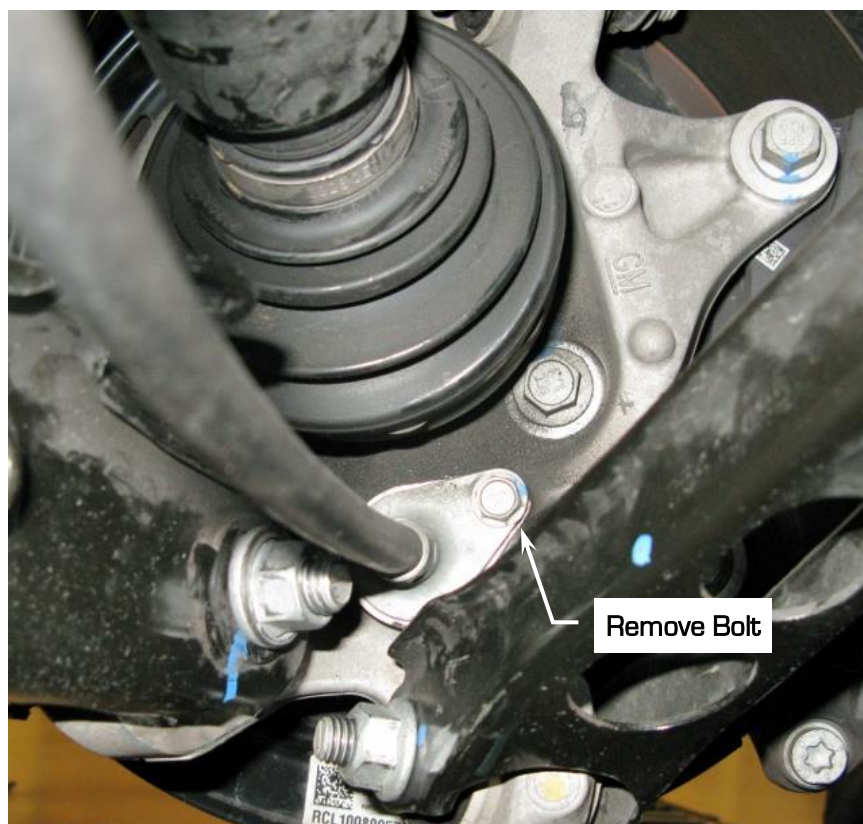

Figure 3 - Loosen Park Brake Cable

5. Disconnect the rear sway bar end links from the rear uprights on both sides of the vehicle using a 15mm wrench (Figure 4).



Figure 4 - Disconnect Sway Bar End Links

- Support the lower control arm assembly with a floor jack. Remove the lower shock bolt from the lower control arm using an 18mm socket. Release the floor jack to allow the lower control arm assembly to droop down.

NOTE: We removed the wheelhouse splash shield to better show the installation. They can be removed by removing the following fasteners (Figure 5).

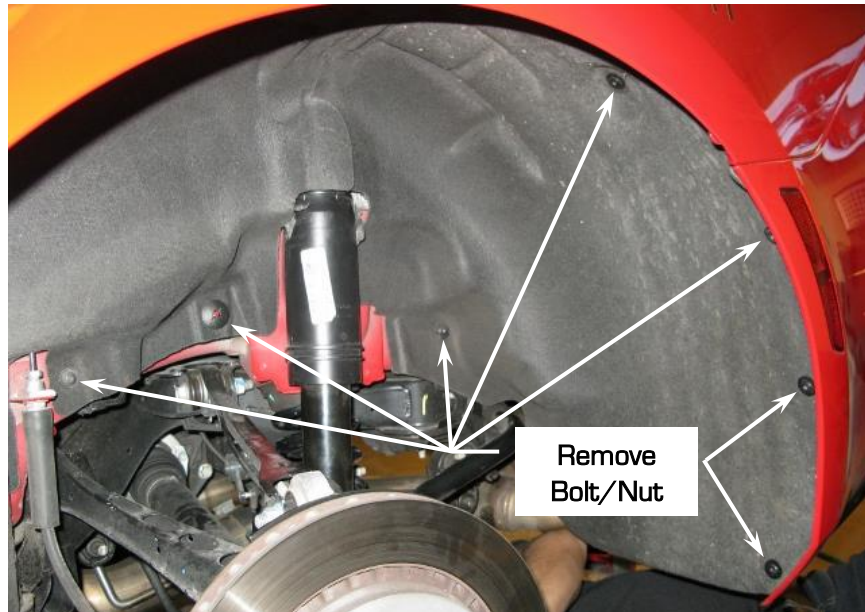

Figure 5 – Remove Shield (if necessary)

- Remove the 3 flange nuts that hold the upper shock mount to the vehicle using a 15mm socket. They are accessible through the wheel house (Figure 6). Save the flange nuts for reinstallation.



Figure 6 – Remove Upper Shock Mount Nuts

- Disconnect the magnetic ride control sensor. Lift up on the gray lock and pull the connector out (Figure 7 on the next page).



Figure 7 – Disconnect Magnetic Ride Control

9. The OEM shock can now be removed from the vehicle (Figure 8).



Figure 8 – Remove OEM Shock

10. With the lower control arm assembly supported with a floor jack, remove the outer bolt from the trailing link first from the upright using an 18mm wrench and socket. Next remove the lower control arm outer bolt from the upright using an 18mm socket and 15mm wrench (Figure 9). **CAUTION:** Be aware that the suspension is usually under some preload and can spring upward once the bolt is removed.

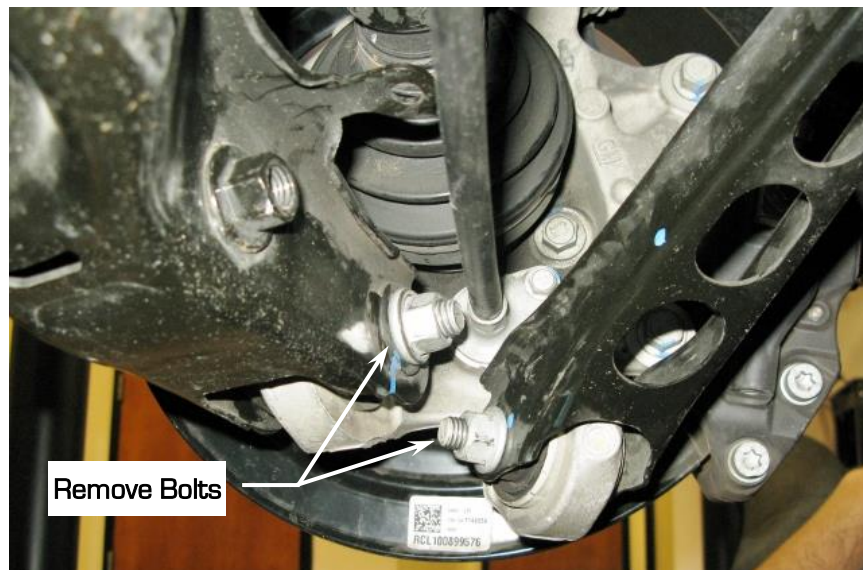

Figure 8 – Remove Suspension Bolts

11. In order to remove the coil spring, Detroit Speed recommends installing the lower shock bolt back into the lower control arm. You can then use a pry bar to push the lower control arm down to be able to remove the coil spring (Figure 9).

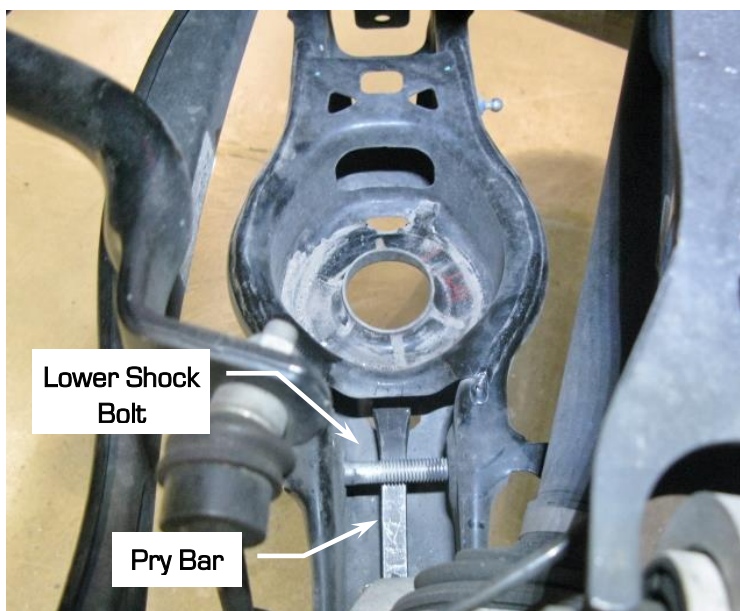

Figure 9 - Remove Coil Spring

12. Identify the left and right hand upper shock mount from the kit for each side of the vehicle. They can only be installed one way. **NOTE:** If you have also purchased the Detroit Speed Rear Coilover Tower Brace Kit (P/N: 042433), refer to these instructions before you install the Detroit Speed Rear Coilover Conversion Kit.
13. Bolt the correct upper shock mount to the vehicle using the OEM flange nuts that were used to hold the OEM shock to the vehicle (Fig. 10). Torque the flange nuts to 40 ft. /lbs.



Figure 10 - Install Upper Shock Mount

14. Next, install the helper spring on the shock. Thread the spanner nut up towards the upper shock mount to allow room to install the coilover spring and helper spring on the shock. Remove the spring seat from the shock by moving it off the shock mount with a rubber hammer and removing the retaining ring (Figure 11 on the next page).



Figure 11 - Remove Spring Seat & Retaining Ring

15. Install the Torrington Bearing set (Figure 12) up against the spanner nut before the coilover spring and helper spring are installed onto the shock. Install one thrust washer, followed by the roller bearing and then another thrust washer.



Figure 12 - Torrington Bearing Set

16. With the Torrington bearing set in place, slide the helper spring up onto the shock and against the Torrington bearing set and the spanner nut. Next, install the stacked spring divider with the short guide into the ID of the helper spring (Figure 13).

NOTE: The Detroit Speed Rear Coilover Kit allows you to lower the factory ride height by 1-1/2" or more from factory ride height. If you choose to lower your Camaro this far, Detroit Speed recommends using the provided helper springs and spring dividers. If you plan on lowering your ride height by 1" or less, the helper springs and spring dividers are not necessary. The purpose of the helper springs, is to prevent the coilover spring from losing its pre-load when the suspension is in full droop, such as when you raise the vehicle on jack stands and the rear suspension is hanging all the way down until the shocks reach full extension.



Figure 13 - Install Helper Spring & Divider

17. Next, install the coilover spring onto the shock and up against the spring divider. Install the spring seat back past the shock mount and re-install the retaining ring into the shock mount. Slide the spring seat back over the retaining ring in the shock mount so it locks in place.
18. Adjust the spanner nut down against the spring so there is pressure against the springs.
NOTE: For a starting point, Detroit Speed recommends moving the spanner nut down so there is 1" to 1-1/2" of threads showing between the end of the shock and the spanner nut, depending on where you prefer your ride height (Figure 14). You will still need to adjust the spanner nut when you do your final ride height adjustment.

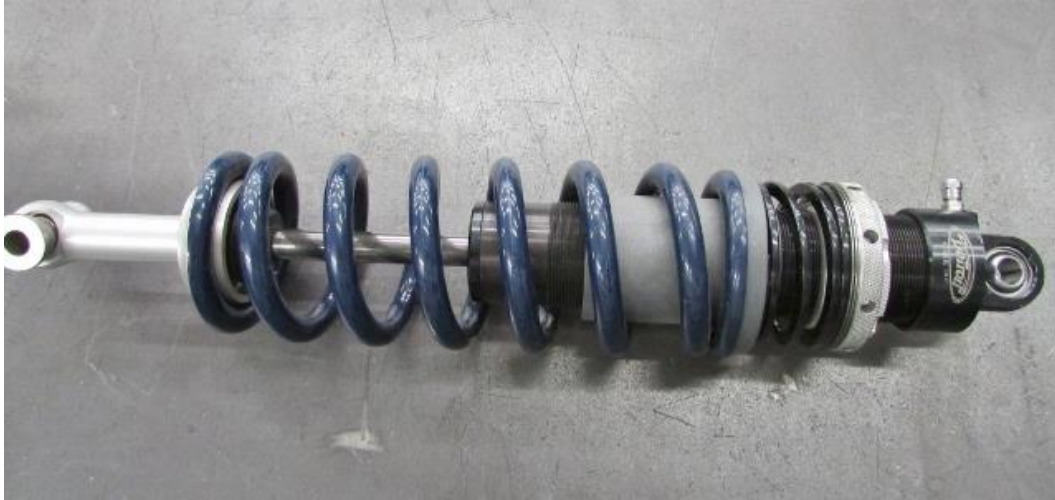

Figure 14 - Assembled Coilover Shock & Spring

19. Install the coilover shock assembly with the body side up, into the upper shock mount. Place one of the steel bushings over the provided 1/2"-20 x 2-1/2"L socket head cap screw. Position the body side of the shock into the upper shock mount and install the socket head cap screw and bushing through the upper shock mount and shock (Figure 15). **NOTE:** Make sure the shock valve is pointing outward from the vehicle.



Figure 15 - Install Coilover Shock

20. Apply anti-seize to the threads of the bolt and install one of the provided 1/2" AN washers and Nylock nuts onto the socket head cap screw and torque to 60 ft. /lbs.
21. Place 2 of the provided tapered spacers in the lower shock eyelet. Use a floor jack to bring the lower control arm into position on the lower shock eyelet. Make sure the two tapered spacers are in position and the adjustment window is facing rearward if you have the double adjustable shocks (Figure 16 on the next page). Re-use the original OEM bolt and nut and torque the lower shock bolt to 74 ft. /lbs. +90-105°.



Figure 16 - Install Tapered Spacers

22. Re-attach the lower control arm and trailing link to the upright (Figure 17). Torque the outer lower control arm bolt to 111 ft. /lbs. +90-105°. Torque the outer lower trailing link bolt to 74 ft. /lbs. +90-105°.



Figure 17 - Re-attach Lower Control Arm & Trailing Link

23. Repeat steps 6 through 22 for the opposite side of the vehicle.

24. Re-install the parking brake cable and retention bolt into both uprights. Re-attach the ride height sensors to the lower control arms on both sides of the vehicle. They should snap back in place.
25. Re-attach the rear sway bar end links to both uprights (Figure 18 on the next page). Using a 15mm socket, torque the bolts to 43 ft. /lbs.



Figure 18 - Re-attach Sway Bar End Links

26. Before the lower control arm assembly covers are re-installed, verify all the hardware is torqued (Figure 19). Re-install the lower control arm covers using the original push pins.



Figure 19 - Final Coilover Shock Assembly

27. Wire tie the magnetic ride control sensor and harness out of the way. **NOTE:** Detroit Speed recommends using the magnetic ride control shock simulator kit from X-ineering Electronics. Visit their site at www.xineering.com.
28. If you had removed the wheelhouse splash shields, re-install them at this time. Put the rear wheels back on and torque the lug nuts to proper OEM specs.
29. Set the final ride height with the following procedures using the coilover nuts. Lock the coilover jam nuts and set screws when finished.
- With the vehicle assembled with all components installed, adjust the vehicle ride height. Before adjusting the ride height, Detroit Speed recommends cleaning the threads of the shock. Once the threads are clean, Detroit Speed recommends applying dry bicycle chain lube to the threads of the shock body before adjusting the spanner nut and compressing the coilover spring. Allow the chain lube to dry before adjusting the spanner nut.
 - Detroit Speed does include a Spanner Tool (P/N: 031060) to adjust ride height however if you have the double adjustable coilover shocks (P/N: 042430-D), Detroit Speed does offer an Adjustment Tool available as P/N: 031061 if needed (Figure 20).



Figure 20 - Detroit Speed Spanner & Adjustment Tools

30. Have a professional alignment completed with the following specifications below for recommended alignment setting for performance street use (Figure 21) or track use on a street tire (Figure 22). **NOTE:** Increase negative camber for non-DOT racing tires.

Alignment Specifications	
Rear	
Camber	-0.50° (-0.25° to -0.75°)
Toe	0 (+/- .030")

Figure 21 - Specifications are listed as nominal with a range in parentheses

Alignment Specifications	
Rear	
Camber	-0.75° (-0.5° to -1.0°)
Toe	1/16" Toe-in (1/32" to 3/32")

Figure 22 - Specifications are listed as nominal with a range in parentheses

Single Adjustable Shock Adjustment Procedure

To change from the recommended “Detroit Tuned” valving, adjustments can be made independently to the rebound setting. The rebound is controlled by the knob at the lower shock mount (Shock is mounted body side up). The knob rotates clockwise (+) to increase the damping and counterclockwise (-) to decrease the damping (Figure 23a).



Figure 23a - Detroit Speed Single Adjustable Shock

To return to the Detroit Speed recommended settings, turn the knob clockwise (+) to full damping. Once at full damping, turn counterclockwise (-) to reach the recommended settings. Refer to Figure 23b for the recommended starting setting.

Rebound (Shaft Knob)..... 15 Open (counterclockwise, -)

Figure 23b - Detroit Speed Recommended Settings

Adjuster Operation

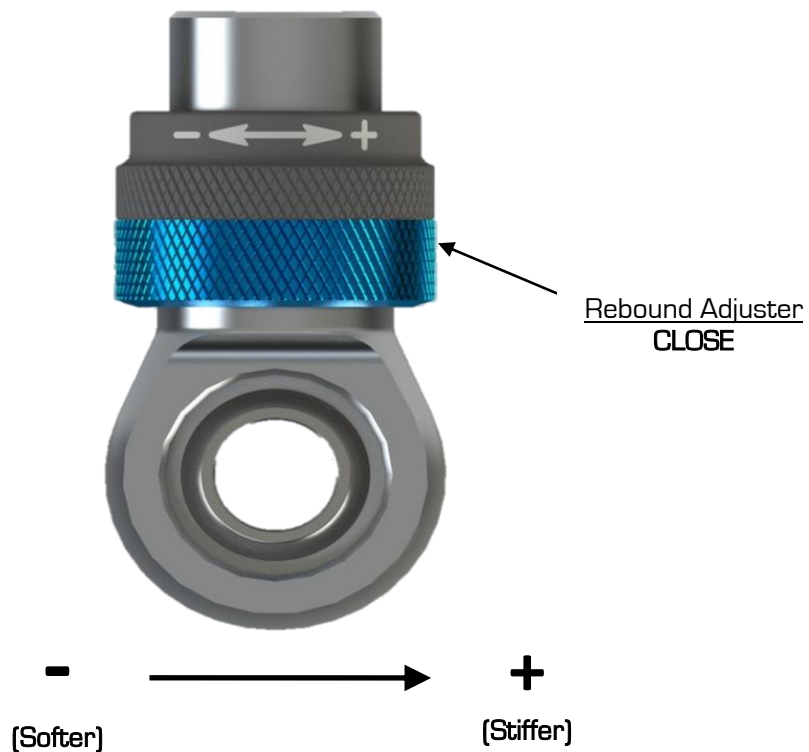

- **Adjuster (60-64 Clicks)**

The low-speed adjuster is a “clicker” style adjuster meaning that its adjustment is measured by detents located inside the blue adjuster knob. There are 16 clicks per 1 revolution of the knob. It uses a right-hand thread in its operation which means as you increase low-speed, the adjuster will move up on the eyelet. The recommended change for an adjustment is 8 clicks at a time. The low-speed adjuster’s reference position is **full stiff** (closed, or all the way up) and referred to -0 (-0 = full stiff, -64 = full soft).

- **Tuning Notes**

- **Racetrack**

- For more grip, soften the damping.
- For increased platform control, stiffen the damping.

- **Street**

- For a more comfortable ride, soften the damping

***DO NOT FORCE KNOB WHEN IT STOPS TURNING, YOU MAY DAMAGE THE ADJUSTER AND INTERNAL HARDWARE**

Double Adjustable Shock Adjustment Procedure

To change from the recommended “Detroit Tuned” valving, adjustments can be made independently to both the high and low speed settings. The rebound is controlled by the sweepers at the lower shock mount. The sweepers rotate clockwise (+) to increase the damping and counterclockwise (-) to decrease the damping (Figure 24a).



Figure 24a - Detroit Speed Double Adjustable Shock

When adjusting the low speed rebound start at full (+) position, when adjusting the high speed rebound start at full (-) position. To return to the Detroit Speed recommended settings turn the sweeper clockwise(+) to full damping for the low speed setting, and counterclockwise (-) to full damping for the high speed setting. Once at full damping, turn counterclockwise (-) for the low speed setting, and clockwise (+) for the high speed setting to reach the recommended settings. Refer to Figure 24b for recommended starting settings.

Low Speed Rebound (Sweeper)..... 15 sweeps (counterclockwise)(-)
 High Speed Rebound (Sweeper)..... 2 sweeps(clockwise)(+)

Figure 24b - Detroit Speed Recommended Settings

Adjuster Operation

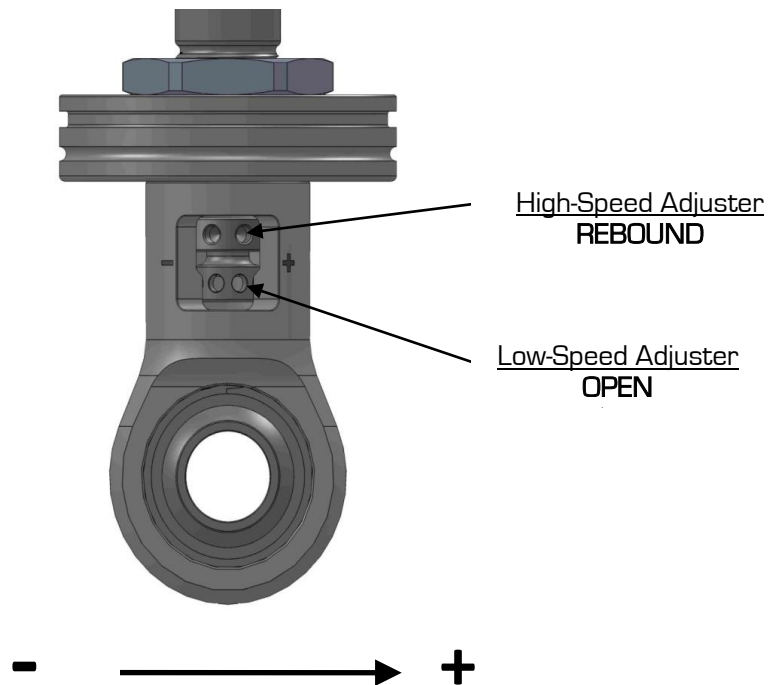

- **High-Speed Adjuster (12 Sweeps)**

The high-speed adjuster is a “sweep” style adjuster meaning that its adjustment is measured by the location of the adjuster in the eyelet window. It uses a left-hand thread in its operation which means; as you increase high-speed, the adjuster will move down in the window*. The high-speed adjuster’s reference position is **full soft** and referred to as +0 (+0 = full soft, +12 = full stiff).

- **Low-Speed Adjuster (25 Clicks)**

The low-speed adjuster is a “clicker” style adjuster meaning that its adjustment is measured by detent grooves located inside the high-speed shaft. It uses a right-hand thread in its operation which means; as you increase low-speed, the adjuster will move up in the window. The low-speed adjuster’s reference position is **full stiff** and referred to as -0 (-0 = full stiff, -25 = full soft).

**The low-speed adjustment does not change when adjusting the high-speed.*

Once again, we appreciate your business.

If you have any questions before or during the installation of this product please contact Detroit Speed at tech@detroitsspeed.com or 704.662.3272

Legal Disclaimer: *Detroit Speed, Inc. is not liable for personal, property, legal, or financial damages from the use or misuse of any product we sell. The purchaser is solely responsible for the safety and performance of these products. No warranty is expressed or implied.*