

**VELOCITY SERIES SUSPENSION**

Why own a muscle car you hate to drive? A great suspension is the key to a great driving car. That is why Ground Up created our Velocity Series Suspension Kits. Our Velocity line of suspensions offer you the chance to update and upgrade your suspension while maintaining your budget. Whether you are looking for an upgraded system, a stock replacement system or just a basic budget friendly system, Ground Up has you covered.



E-DIX69

**Value Front Suspension Kit**

This kit is perfect for your daily driver or restoration on a budget. It includes all high quality imported suspension parts.

- 2 Upper Ball Joints
- 2 Lower Ball Joints
- 4 Lower Control Arm Bushings
- 4 Upper Control Arm Bushings
- 2 Outer Tie Rods
- 2 Inner Tie Rods
- 2 Stabilizer End Links
- 2 Adjustor Sleeves
- 2 Sway Bar Bushings

E-DIX69 1968-74 All .....182.84 kit

No volume discount.



3-18119G



**Energy Suspension Hyperflex Kit**

These complete Hyperflex kits include all the bushings for the suspension, subframe and include a transmission mount.

Add G to the part number for black. Add R to part number for red.  
Example: 3-18119G is for 68-74 in black.

3-18119\_ 1968-74 Mono .....272.99 kit  
3-18118\_ 1968-74 Multi .....272.99 kit



DIX-69

**Deluxe OEM Front Suspension Kit**

This is the ultimate OEM suspension kit! Each kit includes the finest quality OEM components.

- 2 Upper Ball Joints
- 4 Lower Control Arm Bushings
- 2 Lower Ball Joints
- 4 Upper Control Arm Bushings
- 2 Outer Tie Rods
- 2 Stabilizer End Links
- 2 Inner Tie Rods
- 2 Adjustor Sleeves
- 1 Idler Arm

DIX-69 1968-74 All .....291.28 kit

Ships Oversized. No volume discount.



DJR-69

**Junior OEM Front Suspension Kit**

This kit is perfect for freshening up your front suspension! Each kit includes the finest quality OEM components.

- 2 Upper Ball Joints
- 4 Lower Control Arm Bushings
- 2 Lower Ball Joints
- 4 Upper Control Arm Bushings
- 2 Outer Tie Rods
- 2 Stabilizer Ends Links

DJR-69 1968-74 All .....185.14 kit

Ships Oversized. No volume discount.



6874SFK-P



**Polygraphite Complete Front End Kit**

For the ultimate in performance, install a polygraphite front end kit! This kit offers increased longevity and better performance than the stock rubber front end components. Kit includes upper and lower ball joints, inner and outer tie rods, tie rod adjusting sleeves, idler arm and control arm bushing kit and bump stops.

6874SFK-P 1968-74 All .....338.66 kit

End link kit sold separately. No Volume Discount. Ships Oversized.



6874FK-P

**Polygraphite Basic Front End Kit**

Polygraphite bushings used in this kit are the ultimate combination of polyurethane and graphite. You get performance and durability with superior lubricating qualities which provides smooth operation. Kit include upper and lower ball joints, outer tie rods, control arm bushing kit and lower bump stops.

6874FK-P 1968-74 All .....228.37 kit

Ships Oversized. No Volume Discount.

### Individual OEM Suspension Components

Unlike most other suspension components on the market, our line consists of quality OEM parts where available. You can see the difference when you start taking a look! US made rubber and sleeved bushings for a smooth installation, OEM "cast" steel tie rods and center links that feature grease fittings in the correct locations, adjustment sleeves and stabilizer links with correct "true" threads.



### Ball Joints

FA-487	1968-74 All Upper.....	22.95 ea.
FA-688	1975-79 All Upper.....	26.95 ea.
FA-993	1968-74 All Lower.....	22.95 ea.
FA-291	1975-79 All Lower.....	26.95 ea.



### Outer Tie Rods

Correct OEM cast steel outer tie rods. The highest quality original style suspension products on the market! Fits LH or RH.

ES-381	1968-74 .....	29.95 ea.
ES-441RL	1975-79 .....	29.95 ea.



### Inner Tie Rods

Correct OEM cast steel inner tie rods. The highest quality original style suspension products on the market!

ES-681	1968-74 LH/RH .....	29.95 ea.
ES-442L	1975-79 LH .....	34.95 ea.
ES-443L	1975-79 RH.....	34.95 ea.



### Adjustment Sleeves

OEM style adjustment sleeve for proper adjustment of tie rods.

ES-350	1968-74 LH/RH .....	14.95 ea.
ES-2004	1975-79 LH/RH .....	14.95 ea.



### Center Drag Links

DK-0142	1968-74 .....	95.99 ea.
DS-829	1975-79 .....	79.95 ea.

No Volume Discount



### Tie Rod Dust Boots

Correct tie rod end dust boots. Approx. 1-3/16" on bottom and 1-1/4" on top with a 1/2" hole.

ES-48DB	1962-79 4pc OE Style.....	23.95 kit
9-13101G	1962-79 2pc Poly Black.....	4.99 pr.
9-13101R	1962-79 2pc Poly Red.....	4.99 pr.



### DSE Tubular Adjustment Sleeves

Tubular tie rod adjustors improve the strength and integrity of your steering system over stock. The tubular design is stiffer than the OEM split clamp adjustor and weighs less.

DSE090101B	1968-74 Black .....	72.99 kit
DSE090101G	1968-74 Grey.....	65.95 kit

No Volume Discount



### Idler Arms

D-18718	1968-74 All .....	39.95 ea.
K-6186	1975-79 w/o Rally.....	32.95 ea.
BPX-9873	Bolts .....	3.95 pr.

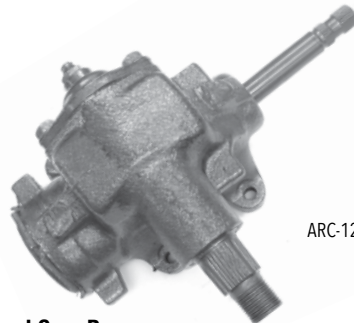

### Manual Gear Boxes

Complete remanufactured original Saginaw assemblies. No core charge.

ARC-12A	1968-69 24:1 Standard .....	289.95 ea.
ARC-12B	1970-76 24:1 Standard .....	289.95 ea.
ARC-12SF	1968-74 16:1 Quick.....	309.95 ea.

Use ATE-8869B coupler with ARC-12SF.

No volume discount. Ships UPS Oversized



### Power Steering Gearbox Kits

Our kit comes with steering box, GM steering coupler (rag joint) and correct attaching bolts. Will fit 1968-74 Nova. No core charge!

#### 1968-74 Nova

GBK-1F	Fast Ratio 3-3.5.....	293.14 kit
GBK-1SFF	Super Fast Ratio 2.5.....	318.68 kit

No volume discount. Ships UPS Oversized



### Manual Steering Box Kits

Our kit comes complete with the steering box, rag joint and correct bolts to mount the box to the frame. No core charge!

ARC-12AK	1968-69 24:1 Standard .....	327.48 kit
ARC-12BK	1970-76 24:1 Standard .....	327.48 kit
ARC-12SF	1968-74 16:1 Quick.....	309.95 ea.

No volume discount.

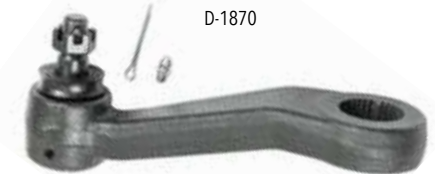

### Pitman Arms

OEM pitman arm.

DA-985	1968-74 Manual .....	75.95 ea.
D-1870	1968-72 Power.....	69.95 ea.
DPA-73	1973-74 Power.....	65.95 ea.
BX-64K	Nut w/ Washer for P/S.....	6.95 ea.



**1968-74 Control Arms**

OE style reproduction upper control arms with ball joint shaft and bushings. All control arms are powder coated in correct semi gloss black and are ready to install. Control arms are available individually or as a specially priced complete kit!

KAR-KIT	1968-74 Complete Control Arm Kit	389.97 kit
KAU-6L	1968-74 Upper LH only	109.99 ea.
KAU-6R	1968-74 Upper RH only	109.99 ea.
KAL-9L	1968-74 Lower LH only	124.99 ea.
KAL-9R	1968-74 Lower RH only	124.99 ea.

*Ships Oversized. No volume discount.*



**Tubular Control Arms**

These tubular control arms include everything you need to bolt them on and go. They are black powder coated for a nice looking and long lasting finish.

UCA6769-KIT	1968-74 Uppers & Lower	397.43 kit
-------------	------------------------	------------



**1966-67 Control Arms**

OE style reproduction control arms for your 1966-67 Nova. The upper control arms include upper ball joints and shafts with bushings already installed. Lower control arms include the lower ball joints and bushings already installed.

KAU-66L	1966-67 Upper LH	160.99 ea.
KAU-66R	1966-67 Upper RH	160.99 ea.
KAL-66L	1966-67 Lower LH	149.99 ea.
KAL-66R	1966-67 Lower RH	149.99 ea.



**Control Arm Shaft Kit**

New OEM shaft, bushings, washers & nuts.

FA-1019	1968-74 All	49.99 kit
FA-7479	1975-79 All	62.95 kit

DS-594



**Control Arm Shims**

DS-594	1/16"	2.95 ea.
DS-595	1/8"	2.95 ea.



**Upper Arm Bushings**

FB-149	1968-74	6.95 ea.
K-6144	1975-79	10.95 ea.



**Lower Arm Bushings**

FB-6076	1968-74 Round	19.95 pr.
---------	---------------	-----------

BPB-1430



**Lower Control Arm Bolt**

Original GM bolt with correct reduced body shaft and pointed end. Includes correct locking nut.

BPB-1430	1968-74 All	8.99 ea.
----------	-------------	----------



**Upper Control Arm Bolt & Washer Kit**

Correct heavy cup washers and correct OEM bolts for retaining upper bushings into arms.

BPX-8542	1968-74 All	19.95 kit
----------	-------------	-----------



**Control Arm Bumpers**

Correct upper and lower control arm bumpers.

DCE-2410	1968-74 Lower	7.95 ea.
DCE-9222	1975-79 Lower	12.95 ea.
DCE-4220	1968-74 Upper	7.95 ea.
DCE-2014	1975-79 Upper	8.95 ea.
DCE-4220K	1968-74 Kit (4)	23.85 kit



**Energy Suspension Control Arm Bumpers**

These polyurethane control arm bumpers offer increased performance and longevity over stock.

Add G to the part number for black. Add R to part number for red. Example: 3-2134G is for 67-81 in black.

9-9151_	1968-74 All Upper	10.99 pr.
9-9154_	1968-74 All Lower	19.99 pr.
ENGGIT-1_	1968-74 Upper & Lower Kit	27.88 kit

BPX-0918



**Control Arm Bolt Kit**

Correct OEM serrated bolts with special locking nuts.

BPX-0918	1968-74 All	20.99 kit
----------	-------------	-----------

DSE031713



**DSE Camber/Caster Kit**

This kit allows you to adjust camber easily with our one-piece slotted camber shims. Each shim is machined from 6061 aluminum and is then anodized black for durability. Includes four 1/16" shims, four 1/8" shims and two 1/4" shims.

**With DSE Subframe**

DSE031713	1962-74	98.99 kit
-----------	---------	-----------

**With OEM Subframe**

DSE031714	1968-74	98.99 kit
DSE031715	1975-79	98.99 kit

FSA-02



**Steering Arms**

OE style reproduction steering arms for your worn or missing originals.

FSA-02	1966-74	72.99 pr.
--------	---------	-----------

*Note: With 5 Lug Hubs*



DSE030101

**DSE Tubular Upper Control Arm Kit**

These DSE tubular upper control arms are a direct replacement for your stock control arms and offer better suspension geometry and more strength which equals better handling and performance. Everything needed to install these new control arms is included in this COMPLETE kit.

DSE030101 1968-74 All ..... 698.99 kit  
Installation should be followed by a professional alignment.  
Ships Oversized. No volume discount.



DSE031201



DSE031204

**DSE Tubular Lower Control Arm Kit**

These DSE tubular lower control arms are a direct replacement for your stock control arms and offer better suspension geometry and more strength which equals better handling and performance. Everything needed to install these new control arms is included in this COMPLETE kit.

DSE031201 1968-74 with  
Stock Springs ..... 724.99 kit  
DSE031202 1968-74 with  
DSE Coilover Springs ..... 709.99 kit  
Installation should be followed by a professional alignment.  
Ships Oversized. No volume discount.

**ENERGY SUSPENSION**  
Performance POLYURETHANE Components



**Polygraphite Control Arm Bushings**

These Poly Graphite bushings from Energy Suspension offer better handling than stock and are impervious to the elements. Add G to the part number for black. Add R to part number for red. Example. 3-3160G is for 62-67 in black.

3-3160_	1962-67 All.....	72.99 kit
3-3101_	1968-74 All.....	85.99 kit
3-3105_	1975-79 All.....	85.99 kit



DSE030201

**Delrin Lower Bushings**

These Delrin bushings eliminate deflection and greatly improve response. The steel outer housings can be welded to the control arm.

DSE030201 1968-74 All ..... 155.99 kit  
Works great for street cars as well as race cars.



DSE030401

**Urethane Upper Bushings**

These urethane bushings are designed as an upgrade over stock for improved handling.

DSE030401 1968-74 All ..... 61.99 kit



DSE030501

**DSE Jounce Rebound Bumpers**

These urethane bumpers can be used for jounce and rebound control for your stock control arms. The bumper dimensions are 1-9/16" tall and 1-5/8" base diameter. They are sold in pairs.

DSE030501 1968-74 ..... 17.99 pr.



DSE031005

DSE031006



DSE032102

**DSE Shock Upgrades**

The DSE subframe comes with base shocks, but it can be upgraded with the following:

**Double Adjustable Shocks**

Includes all features of the base shock plus installed independent compression and rebound adjustments with the simple turn of a knob. Low friction components provide responsive, consistent, fade free performance.  
DSE031005 Upgrade ..... 1560.99 pr.

**Remote Canister Monotube Double Adjustable Shocks**

Includes all features of base shock and double adjustable shocks. Incorporates a gas charged bladder design to provide both high frequency and low speed dampening control.  
DSE031006 Upgrade ..... 1547.99 pr.

**M2 Remote Canister Shock Mounts**

These billet aluminum M2 shock mounts are manufactured for securing your remote shock canisters to the vehicle.  
DSE032102 Mounts ..... 134.99 pr.



DBB-67K



**BUY'N SAVE**  
WITH KITS

**Body Mounting Kits**

Complete with everything you need to mount your body to the frame including correct rubber bushings with steel inserts and factory style OEM flanged head frame bolts with washers!

DBB-67K 1968-74 All.....55.17 kit

BPB-2230



**Body Bolt Kit**

Correct OEM body mounting kit complete with (4) correct body bolts, (4) correct large washers, (2) correct radiator support bolts, (2) bushing washers, (2) correct spacer washers and (2) nuts & lock washers.

BPB-2230 1968-74 .....24.95 kit



DCI-3025

**Body Mounting Bushing Kit**

Correct OEM style rubber bushings with steel inserts for mounting body to frame; complete with radiator support bushings.

DCI-3025 1968-74 .....39.95 kit  
DCI-892 1975-76 .....69.99 kit  
DCI-893 1977-79 .....69.99 kit



DRS-67H

**Radiator Support Bushings**

Complete kit with all bushings and hardware for mounting radiator support to car.

DRS-67H 1968-74 All .....21.52 kit

**Front Rad. Support**



**Middle**



**Rear**



DSE010201

DSE010801



**DSE Solid Body Mounts**

DSE solid body mounts provide a simple approach to eliminating the flex that occurs between the body and subframe connection. This will improve vehicle handling response by increasing chassis stiffness. CNC machined from billet aluminum and then hard coated. Stainless bolts sold separately.

DSE010201 1968-74 1/2 Height .....156.99 kit  
DSE010301 1968-74 Stock Height .....168.99 kit  
DSE010801 Stainless Bolts .....114.99 kit  
*No Volume Discount*

RFR-646



**Subframe Repair Plates**

Stamped steel plates for repairing your rusted or damaged subframe mounting points. Complete set of (6) includes radiator support.

RFR-646 1968-74 .....56.99 kit

3-4142G



**Poly Graphite Body Mounting Kit**

These polyurethane body mounts offer increased performance and longevity over stock bushings.

3-4142G 1968-74 All Black .....88.99 kit  
3-4142R 1968-74 All Red .....89.99 kit



DSE031401

**Front Sway Bar Kit**

Eliminate poor handling by installing one of these sway bars! It includes sway bar, brackets, bushings and end links to replace your old, small bar.

DZ2-1000	1962-67 All.....	184.99 kit
DAA-136	1968-74 1".....	184.99 kit
DAA-599	1968-74 All 1-1/8".....	197.99 kit

No Volume Discount. Ships Oversize 2.



DSE031401

**Detroit Speed Front Sway Bar Kit**

This larger than stock bar is powder coated black and comes with everything you need to bolt it on including greasable polyurethane bushings and end links.

DSE031401	1968-74 All 1-1/8" Hollow.....	259.99 kit
-----------	--------------------------------	------------

No Volume Discount. Ships Oversize 2.



DBB-6769K

**1968-74 Sway Bar Bushing Kits OE Style**

These kits come complete with front sway bar bushings, brackets and bolts.

DBB-6769K	1968-74 11/16" Bar.....	49.95 kit
DBB-671K	1968-74 1" Bar.....	49.95 kit

No volume discount.



DHB-69

**Sway Bar Bushings**

DHB-69	1968-74 Repro.....	12.95 pr.
DCI-679	1968-74 1-1/16" Bar.....	9.95 pr.



3-5202G



**Energy Suspension Sway Bar Bushings**

These polyurethane body bushings offer increased performance and longevity over stock.

Add G to the part number for black. Add R to part number for red. Example. 3-5202G is for 68-74 in black.

3-5202_	1968-74 11/16" bar.....	22.99 pr.
3-5203_	1968-74 13/16" bar.....	22.99 pr.



9-8125G

**Energy Suspension Sway Bar End Links**

These Polyplus sway bar end links will improve handling and steering response.

9-8125G	1968-79 Black.....	20.99 pr.
9-8125R	1968-79 Red.....	20.99 pr.



DSL-90

**Stabilizer End Links**

Complete kit for one car.

DSL-90	1968-79 All.....	14.95 kit
--------	------------------	-----------



BAR-1295

**Sway Bar Brackets**

Correct mounting bracket for front sway bar.

DBB-157	1968-74 Front 1-1/16.....	7.95 ea.
DBB-81R	1968-74 Rear OEM Bar.....	16.99 ea.
BAR-1295	Correct Front Bar To Frame Bolt.....	0.75 ea.
BAR-1295K	Correct Front Bar To Frame Bolts.....	2.55 kit



DCS-6080



**Coil Springs**

Brand new OEM replacement coil springs sold in matched pairs. These are not cheap aftermarket springs. These springs will restore your car to the original ride height.

DCS-6080	1962-67 6 cyl and V8 w/o AC except 327.....	75.95 pr.
DCS-6246	1962-67 All with 327.....	84.99 pr.
DCS-6246	1962-67 All Cars w/ AC.....	84.99 pr.
DCS-6320	1968-74 SB w/o A/C.....	109.99 pr.
DCS-0009	1968-74 SB w/ A/C.....	91.99 pr.
DCS-0009	1968-74 All BB.....	91.99 pr.

No Volume Discount



DSI-170

**Coil Spring Insulators**

Rubber insulators for the top of the front coils.

DSI-170	1968-79 All.....	17.99 pr.
---------	------------------	-----------



**DSE 2" Dropped Front Coil Springs**

These DSE 2" drop coil springs will lower the front of your car easily to give it a pro-touring stance. These springs will also provide great ride and handling.

DSE031115	1968-74 SB, LSX.....	212.99 pr.
DSE031118	1968-74 BB.....	258.99 pr.

Ride height may vary depending on weight differences of cars.



RSS-1625W

DSP-62

**Front Coil Spring Seat & Perch**

Reproductions of these commonly rotted out coil spring mounts.

RSS-1625W	1966-67 All Upper Seat.....	24.95 ea.
DSP-62	1962-67 Lower Perch.....	69.95 pr.

DPX-440

**GM Shock Kit**  
Complete kit featuring 4 gas charged shocks, correct front & rear hardware, grey paint & 4 shock ID decals.

DPX-440 1968-74 All Kit..... 128.60 kit  
NT-2005 1968-74 Front Only .....29.99 ea.  
NT-2201 1968-74 Rear Only .....29.99 ea.  
*No Volume Discount.*

**THIS IS AN EXCLUSIVE GROUND UP PRODUCT**

DSS-F72 DSS-R72

**Spiral Shocks**  
New GM licensed reproductions of the original spiral twist shocks in correct gray color.

DSS-F72 1968-74 All Front.....89.99 ea.  
DSS-R72 1968-74 All Rear.....89.99 ea.  
*No Volume Discount*

**GM Restoration Parts**

**NEW PRODUCT**

**THIS IS AN EXCLUSIVE GROUND UP PRODUCT**

**Koni Front And Rear Shock Kits**  
Are you looking for more performance from your Nova's shocks, and a smooth ride with improved ride and handling qualities? This Koni shock kit is the answer! Koni Classic shocks provide modern shock absorber technology for early muscle cars. Our kit includes: (2) front shocks, (2) rear shocks.

KONI6874X 1968-74 All..... 451.16 kit  
*No volume discount.*

KYB-68X-KIT

**KYB Excel-G Shock Kit**  
Are you looking for more performance from your shocks and a smooth ride? This KYB shock kit is the answer! They feature velocity sensing valving, hard chrome piston rods, twin tube design, low pressure nitrogen gas to prevent foaming of the oil, iron pistons & guide tubes. These shocks are great for normal to moderate driving! Our kit includes: (2) front shocks, (2) rear shocks and hardware.

KYB-68X-KIT 1968-74 All Front & Rear ..... 114.95 kit  
KYB-68F 1968-74 Front Only ..... 34.95 ea.  
KYB-64R 1968-74 Rear Only ..... 29.95 ea.  
*No Volume Discount*

DSR-384

**Shock Mounting Hardware**  
Correct GM rubber bushings, cup washer and nut for one shock.

DSR-384 1962-74 All Front.....7.95 kit

DR-041

**Shock Mounting Stud**  
Correct rear shock mounting stud.

DR-041 1968-74 Rear.....8.95 ea.

BPX-9715

**Shock Mounting Kit**  
Correct GM front shock mounting kit with (4) clips and (4) OEM bolts/washers.

BPX-9715 1968-79 All Front..... 7.99 kit

**ENERGY SUSPENSION**  
Performance POLYURETHANE Components

9-8101G 9-8101R

**Energy Suspension Upper Shock Bushings**  
These are sets of 4 correct front upper Polyurethane shock bushings. Bushings only. No hardware included.

9-8101G 1962-79 2pc Poly Black.....4.99 kit  
9-8101R 1962-79 2pc Poly Red .....4.99 kit

RSF-69F

**Factory Subframe**  
This is an OEM style Nova subframe which is an exact replacement for your rusty, dented, or bent original. There is no longer any need to waste money trying to repair your damaged original subframe. This subframe features factory style welds for an OEM appearance, extra bracing in the lower cross member to add strength while jacking the car (but completely invisible on the outside) and holes and brackets as original. This subframe is very hard to tell from OEM due to all of these correct details.

RSF-68F 1968 All..... 1139.99 ea.  
RSF-69F 1969-72 All..... 1139.99 ea.  
*Ships Truck Freight to a commercial address. No volume discount.*

RSM-1003B

**Coil Spring Upper Mounts**  
Replacement coil spring upper mounts which are located in the subframe. Weld-in.

RSM-1003B 1968-74..... 34.95 pr.

DSE060415

**DETROIT SPEED, INC.**

**DSE LS Engine Mounting Bracket Kit**  
This DSE LS engine mount bracket kit enables easy, no hassle installation of any LS engine into your new DSE hydroformed subframe. This kit mounts the engine in the proper location, provides the correct method of adapting the 3 bolt engine mounts to the 4 bolt LS engine and requires no fabrication. Complete with frame side engine mount stands, CNC aluminum adapter plates and polyurethane engine mounts.

DSE060415 1962-67 SB .....285.99 kit  
DSE060416 1962-67 LS.....306.99 kit  
DSE060401 1968-74 All .....324.99 kit



DTR-7412

**OEM Style Replacement Leaf Springs**

These are excellent OEM replacement leaf springs which will restore the proper rear ride height.

DTR-7910	1968-79 Mono Leaf .....	281.99 pr.
DTR-7412	1968-79 4 Leaf .....	199.95 pr.
DTR-7815	1968-79 5 Leaf .....	179.95 pr.

No Volume Discount. Ships Oversize 2.



DLK-69M

**Leaf Spring Mounting Kit**

This kit comes complete with (4) correct pads, (2) U-bolts and (4) T bolts with (8) nuts. Does one car.

DLK-67	1968-79 Mono.....	54.00 kit
DLK-69M	1968-79 Multi .....	50.80 kit



DSE041101

**Mono-to-Multi Leaf Conversion Kit**

Use this kit to convert your original mono-leaf spring to multi-leaf spring configuration. Kit includes: U-bolts, a hardcoated steel locating pad, aluminum spacers, washers & nuts.

DSE041101	1968-79.....	95.95 kit
-----------	--------------	-----------



DTR-4RBK

**Leaf Spring Rebuild Kits**

Leaf spring rebuild kit includes the correct hardware to disassemble the leaves and put them back together like new.

DTR-4RBK	1968-79 4 Leaf .....	36.95 kit
DTR-5RBK	1968-79 5 Leaf .....	41.95 kit



**Rear Sway Bar Kit**

This complete direct OEM replacement rear sway bar kit comes complete and ready to install with all brackets, bushings, hardware and sway bar. While not technically correct, this sway bar will fit and function as original and is excellent for street, strip, road racing and everything in between!

DSB-5814	1968-74 All 7/8" Bar.....	175.99 kit
----------	---------------------------	------------

*Ships Oversized. No volume discount.*

DSE041501



**DSE Heavy Duty Leaf Spring Shackle Kit**

Upgrade your rear leaf spring and shackle bushings with this heavy duty shackle kit from Detroit Speed. Your choice of polyurethane or Delrin bushings.

DSE041501	1968-74 Polyurethane.....	169.99 kit
DSE041502	1968-74 Delrin .....	324.99 kit

*No Volume Discount*



DSE041633

**DSE Rear Leaf Spring Suspension Kit**

This DSE rear leaf spring suspension kit works great with any DSE front suspension kit. These leaf springs improve handling due to the increased spring rate and are available in either a 2" or 3" dropped ride height. Includes DSE rear leaf springs, heavy duty shackle kit and Koni classic rear shocks.

DSE041633	1968-74 2" Drop.....	924.99 kit
DSE041636	1968-74 3" Drop.....	924.99 kit

*No Volume Discount. Ships Oversize 2. Ride height may vary depending on weight differences of cars.*



DSE031301



**DSE Speed Kit 1**

This exclusive DSE Speed Kit is a complete bolt-on suspension upgrade system designed for ease of installation with no modification to subframe.

This kit includes:

- Tubular Upper & Lower Control Arms
- Koni Classic Front Shocks
- Front 2" Drop Spring • Front Sway Bar

DSE031301	1968-74 SB,LSX .....	2224.99 kit
DSE031304	1968-74 BB .....	2224.99 kit

*Ships Oversized. No volume discount.*



DSE031303



**DSE Speed Kit 2**

Speed Kit 2 improves the handling and performance to the next level and offers ride height adjustment.

This kit includes:

- Tubular Upper & Lower Control Arms • Coil Conversion Kit
- Koni Aluminum Body Coilover Shocks • Coilover Springs • Front Sway Bar

DSE031350	1968-74 SB, LS Base Shocks .....	2549.99 kit
DSE031351	1968-74 BB, Base Shocks .....	2549.99 kit
DSE031350S	1968-74 SB, LS Single Adj Shocks .....	2999.99 kit
DSE031351S	1968-74 BB, Single Adj Shocks.....	2999.99 kit
DSE031350D	1968-74 SB, LS Double Adj Shocks...	3599.99 kit
DSE031351D	1968-74 BB, Double Adj Shocks .....	3599.99 kit

*Ships Oversized. No volume discount.*



DSE031352



**DSE Speed Kit 3**

Speed Kit 3 is the most advanced handling system that you can buy for your stock subframe and gives you the steering performance of today's modern cars.

This kit includes:

- Tubular Upper & Lower Control Arms • Coil Conversion Kit
- Idler Arm • Pitman Arm • Koni Aluminum Body Coilover Shocks
- Coilover Springs • Front Sway Bar • DSE 600 Gear w/ Rag Joint
- DSE Tie Rod Adjusters • Inner & Outer Tie Rod Ends

DSE031352	1968-74 SB, LS Base Shocks .....	3361.99 kit
DSE031353	1968-74 BB, Base Shocks .....	3361.99 kit
DSE031352S	1968-74 SB, LS Single Adj Shocks .....	3704.99 kit
DSE031353S	1968-74 BB, Single Adj Shocks .....	3704.99 kit
DSE031352D	1968-74 SB, LS Double Adj Shocks...	4305.99 kit
DSE031353D	1968-74 BB, Double Adj Shocks .....	4140.99 kit

*Ships Oversized. No volume discount.*



**ENERGY SUSPENSION**  
Performance POLYURETHANE Components



**Energy Suspension Rear Shackle Kits**

Be in control of your suspension while you're maneuvering through turns, doing drag-style launches and braking. Add G to the part number for black. Add R to part number for red.  
*Example. 3-2136G is for 68-74 in black.*

3-2134_	1968-74 Multi.....	125.99 kit
3-2136_	1968-74 Mono.....	125.99 kit

**Bushings Only**

3-2103_	1968-74 Multi.....	70.99 kit
3-2101_	1968-74 Mono.....	70.99 kit



**Energy Suspension Leaf Spring Pads**

These new Hyper-Flex polyurethane spring pads can take the abuse from performance suspensions and are impervious to any contaminants-**GUARANTEED!** Add G to the part number for black. Add R to part number for red.  
*Example. 3-6112G is for 68-74 in black.*

3-6112_	1962-79 Multi.....	27.99 kit
3-6113_	1962-79 Mono.....	24.99 kit



NRD-0045

**Leaf Spring Rear Shackle Kit**

Exact reproduction shackle kit complete with plates, bushings, bolts and nuts. Does 1 car.

NRD-0045	1962-79 All .....	59.95 kit
----------	-------------------	-----------



DSB-8R

**Rear Shackle Bushings**

Exact reproduction rear shackle bushings.

DSB-8R	1968-74 All .....	32.95 kit
--------	-------------------	-----------

BLS-1130

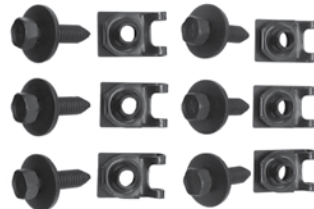

**Front Leaf Spring Bracket Hardware Kit**

Correct bolts and special clips for mounting front leaf spring brackets to car. This kit includes (6) OEM bolts and (6) J nuts.

BLS-1130	1968-79 All .....	16.95 kit
----------	-------------------	-----------

DSP-500



**Leaf Spring Perch**

Correct leaf spring perches for rear axle.

DSP-500	1968-74 Multi.....	69.95 pr.
DSP-501	1968-74 Mono.....	69.95 pr.

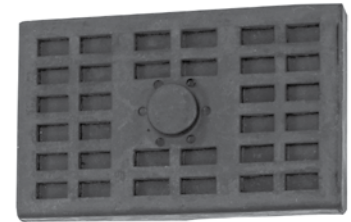

DTE-67

**Leaf Spring Pads**

Correct rubber pads for mounting springs.

DTE-7818	1968-79 Mono.....	6.95 ea.
DTE-67	1968-79 Multi.....	5.95 ea.



BBB-2743

**Front Leaf Spring Eye Bolt**

Correct OEM bolt with washers and special nut for mounting front leaf spring to car. 2 required.

BBB-2743	1968-74 All .....	3.95 ea.
----------	-------------------	----------

BPB-2949



**T-Bolt**

Correct T bolt & nut for mono leaf springs.

BPB-2949	T Bolt.....	6.95 ea.
----------	-------------	----------



BPB-4829

**U-Bolt**

Correct U-bolt & nuts for multi leaf springs.

BPB-4829	U Bolt.....	5.95 ea.
----------	-------------	----------

DSB-99



**Leaf Spring Eye Bushing**

Correct front eye bushing.

DSB-99	1968-74 All .....	19.95 ea.
--------	-------------------	-----------

NJX-283



**Leaf Spring Plates**

Correct lower leaf spring mounting plates.

NJX-283	1968-74 Multi.....	42.95 ea.
---------	--------------------	-----------

**DSE Mini Tub Kit**

This is a complete Detroit Speed & Engineering mini tub kit which includes all of the necessary parts for a complete project package. The original rear seat back and bottom frames must be slightly modified, but the rear seat can be used!

- DSE Deep Tubs
- Rear Shock Crossmember
- Rear Upper Shock Mounts
- Offset Shackles
- Adjustable Leaf Spring Pads
- Lower Shock Plates
- U-Bolts
- Mini-tub Installation CD
- Rear Leaf Springs
- Instructions

DSE041207	1968-74 with 2" Drop.....	1819.99 kit
DSE041208	1968-74 with 3" Drop.....	1819.99 kit
DSE041301	1968-74 Mini Tub Rear Shocks.....	239.99 pr.

**Delrin Upgrade**

Upgrade front and rear bushings to Delrin material.

DSE041503	1968-74 Mini-Tub Kit.....	294.99 kit
-----------	---------------------------	------------

A narrowed fuel tank is required. Ask your sales rep for details! These kits require a 3" axle tube. DSE041301 shocks required. Ships Oversized. No volume discount.



NEW PRODUCT: QA1 SUSPENSION



**QA1 Upper & Lower Tubular Control Arms**

QA1's Street & Race Control Arms. The street arms use a factory replacement ball joint and polyurethane pivot bushings. These work great on vehicles used primarily for cruising and long distance events. The race arms utilize a QA1 Low Friction Ball Joint and low friction, low deflection pivot bushings, providing the added performance needed for drag racing, pro-touring and hardcore street applications. Configured for QA1 Pro Coil Systems, these control arms feature powder coated tubular construction for increased strength and great looks. A bolt-in spring adapter is available separately to allow the control arms to be used with stock springs. All of the upper arms feature an offset cross shaft letting you quickly and easily adjust camber. All of these arms are designed to add 3-4 degrees of caster and 0.5 to 1 degree of negative camber when used together. Includes mounting hardware. Made in the USA.

**Street Arms**

QA1-52417	1968-74 All Upper.....	449.99 pr.
QA1-52419	1968-74 All Lower.....	629.99 pr.
QA1-52418	1975-79 All Upper.....	449.99 pr.
QA1-52420	1975-79 All Lower.....	629.99 pr.

**Race Arms**

QA1-52317	1968-74 All Upper.....	549.99 pr.
QA1-52319	1968-74 All Lower.....	649.99 pr.
QA1-52318	1975-79 All Upper.....	549.99 pr.
QA1-52320	1975-79 All Lower.....	649.99 pr.

No volume discount.



**QA1 Sway Bars**

QA1-52816

Give your chassis the stability it needs to keep your tires planted on the road. These sway bars are an easy bolt-on upgrade to help reduce body roll and handle corners better. For maximum strength and durability, QA1 sway bars are manufactured from either lightweight hollow-core (4130) chromoly steel or heavy duty solid-core (1045) cold formed steel. The bars are formed using precision CNC equipment for a true bolt-on installation, then gloss black powder coated for durability and corrosion resistance. Sway bars include new mounting components to replace old and worn out sway bar bushings and end links. Made in the USA.

QA1-52816	1968-74 All Front 1 1/4".....	249.99 ea.
QA1-52893	1975-79 All Front 1 3/8".....	259.99 ea.

No volume discount.



**QA1 Tie Rod Sleeves**

These QA1 Heavy Duty Tie Rod Sleeves are manufactured from solid steel hex stock then zinc plated for durable good looks and corrosion resistance. These are stronger than stock OE split sleeves and easier to adjust. Made in the USA.

QA1-5251	1968-79 All.....	57.99 pr.
----------	------------------	-----------

No volume discount.

**QA1**



QA1-GD401-10500C

QA1-GS401-10400A

**QA1 Front Coilover Shock Kits**

The QA1 Pro Coil System is a great option for anyone looking for fully adjustable ride height and valving control. Choose a spring rate and adjustability that fits your driving style, adjust the valving to match and you are on your way. These shocks also utilize a fully threaded body that allows you to adjust your ride height for the perfect stance or to finely tune the weight balance for superior handling. Specially designed for QA1's Pro Coil Systems, the American-made lightweight high travel springs have fewer coils and a smaller wire diameter, resulting in increased travel due to the larger distance between the coils. They reduce unsprung weight and react faster, optimizing suspension performance. Adjustable Pro Coil System Features: Available in MOD Series, independent compression and rebound double adjustable, simultaneous compression and rebound adjustable, or drag R Series adjustable. Lightweight Billet Aluminum Coilover Shocks High Travel Springs Easy, Bolt-In Installation Ride Height Adjustable, Made in the USA

SA = single adjustable DA = double adjustable DR = drag series adjustable MO = mod series

**Small Block Included spring rate: 400 Lbs, ideal for front axle weight between 1801-1900 Lbs.**

QA1-GS401-10400A	1968-74 SA.....	545.99 kit
QA1-GD401-10400A	1968-74 DA.....	705.99 kit
QA1-GR401-10400A	1968-74 DR.....	605.99 kit
QA1-MG401-10400A	1968-74 MO.....	1525.99 kit
QA1-GS401-10400C	1975-79 SA.....	545.99 kit
QA1-GD401-10400C	1975-79 DA.....	705.99 kit
QA1-GR401-10400C	1975-79 DR.....	605.99 kit
QA1-MG401-10400C	1975-79 MO.....	1525.99 kit

**Big Block Included spring rate: 500 Lbs, ideal for front axle weight between 2001-2100 Lbs.**

QA1-GS401-10500A	1968-74 SA.....	545.99 kit
QA1-GD401-10500A	1968-74 DA.....	705.99 kit
QA1-GR401-10500A	1968-74 DR.....	605.99 kit
QA1-MG401-10500A	1968-74 MO.....	1525.99 kit
QA1-GS401-10500C	1975-79 SA.....	545.99 kit
QA1-GD401-10500C	1975-79 DA.....	705.99 kit
QA1-GR401-10500C	1975-79 DR.....	605.99 kit
QA1-MG401-10500C	1975-79 MO.....	1525.99 kit

No volume discount.



**QA1 Stocker Star Shocks**

These stock mount adjustable front & rear shocks are available for your Nova. Available in double, single, Drag R Series and non-adjustable options, these shocks provide exactly the ride you want, high performance handling and great looks. These QA1 aluminum shocks are 100% dyno tested and serialized before leaving our factory. Made in the USA. Easy, bolt-in installation. NA = non-adjustable SA = single adjustable DA = double adjustable DR = drag series adjustable

QA1-TN703	1962-67 Rear NA.....	114.99 ea.
QA1-TS703	1962-67 Rear SA.....	159.99 ea.
QA1-TD703	1962-67 Rear DA.....	239.99 ea.
QA1-TN505	1968-79 Front NA.....	114.99 ea.
QA1-TS505	1968-79 Front SA.....	159.99 ea.
QA1-TD505	1968-79 Front DA.....	239.99 ea.
QA1-TN801	1968-79 Rear NA.....	114.99 ea.
QA1-TS801	1968-79 Rear SA.....	159.99 ea.
QA1-TD801	1968-79 Rear DA.....	239.99 ea.

No volume discount.



**QA1 Performance Handling Kits**

Want better handling for your 1967-1969 Camaro? Turn to QA1's handling suspension kits for the best ride that fits your needs. Available in three different levels of performance, these handling kits offer easy, bolt-in installation and seamlessly works with whatever OE component each piece attaches to. You can build your car in stages using our parts list as a road map to get to the level of performance you want and have the peace of mind knowing you won't have compatibility issues.

Level 1 Includes: Front non-adjustable Stocker Star shocks, front sway bar, tie rod adjuster sleeves.

Level 2 Includes: Front single adjustable Pro coil shock system, front sway bar, thrust bearing/spanner wrench kit, upper street control arms, lower street control arms, tie rod adjuster sleeves.

Level 3 Includes: Front double adjustable Pro coil shock system, front sway bar, thrust bearing/spanner wrench kit, upper race control arms, lower race control arms, tie rod adjuster sleeves, ball joint tool kit.

**Level 1 Kits**

QA1-HK01-GMX2	1968-74 w/ shocks.....	709.99 kit
QA1-HK01-GMX3	1975-75 w/ shocks.....	777.99 kit

**Level 2 Kits**

QA1-HK12-GMX2	1968-74 w/ shocks.....	1329.99 kit
QA1-HK03-GMX2	1968-74 w/o shocks.....	2714.99 kit
QA1-HK02-GMX3	1975-79 w/ shocks.....	2293.99 kit
QA1-HK12-GMX3	1975-79 w/o shocks.....	1397.99 kit

**Level 3 Kits**

QA1-HK03-GMX2	1968-74 w/ shocks.....	2714.99 kit
QA1-HK13-GMX2	1968-74 w/o shocks.....	1479.99 kit
QA1-HK03-GMX3	1975-79 w/ shocks.....	2763.99 kit
QA1-HK13-GMX3	1975-79 w/o shocks.....	1547.99 kit

No volume discount.

**NEW PRODUCT: QA1 SUSPENSION**



**QA1 Drag Race Suspension Kits**

Looking for a better launch, straight line stability and consistent performance? Turn to QA1's drag racing suspension kits for a full-vehicle upgrade that fits your needs. Available in two different levels of performance, these drag racing kits offer easy, bolt-in installation and seamlessly works with whatever OE component each piece attaches to.

**Level 1 Includes:** Front R series Stocker Star shocks, upper street control arms, lower street control arms, stock spring seat adapter, tie rod adjuster sleeves.

**Level 2 Includes:** Front Double Adjustable Pro Coil shock system, thrust bearing/spanner wrench kit, Upper race control arms, Lower race control arms, tie rod adjuster sleeves, ball joint tool kit.

**Level 1 Kits**

QA1-DK01-GMX2	1968-74 w/ shocks.....	1829.99 kit
QA1-DK11-GMX2	1968-74 w/o shocks.....	1169.99 kit
QA1-DK01-GMX3	1975-79 w/ shocks.....	1887.99 kit
QA1-DK11-GMX3	1975-79 w/o shocks .....	1227.99 kit

**Level 2 Kits**

QA1-DK02-GMX2	1968-74 w/ shocks.....	2454.99 kit
QA1-DK12-GMX2	1968-74 w/o shocks .....	1226.99 kit
QA1-DK02-GMX3	1975-79 w/ shocks.....	2503.99 kit
QA1-DK12-GMX3	1975-79 w/o shocks .....	1287.99 kit

No volume discount.

**DIRECT FIT!**

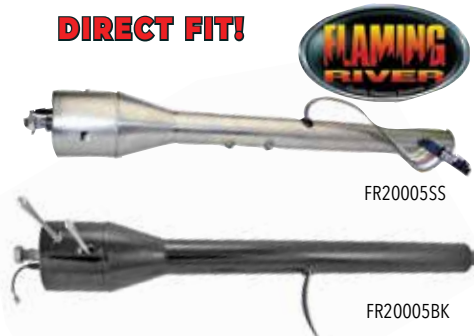

**Flaming River Tilt Steering Columns**

Flaming River offers replacement tilt steering columns for your Nova. They require no welded on attachments or extra relays. Modeled after the popular muscle car Tilt Key Columns, but still attractive enough to put in your street rod. Flaming River manufactures the column complete with a GM coded key assembly, wiring and ignition switch made from state-of-the-art, all new components. **Made in USA.**

FR20005	1962-1966, 1" DD Shaft, Paintable .....	544.99 ea.
FR20005BK	1962-1966, 1" DD Shaft, Black.....	713.99 ea.
FR20005SS	1962-1966, 1" DD Shaft, Polished .....	791.99 ea.
FR21010	1967, 1" 48 Spline Shaft, Paintable .....	621.99 ea.
FR21010BK	1967, 1" 48 Spline Shaft, Black .....	791.99 ea.
FR21010SS	1967, 1" 48 Spline Shaft, Polished.....	859.99 ea.
FR30009	1969-1974, 1" 48 Spline Shaft, Paintable..	897.99 ea.
FR30009BK	1969-1974, 1" 48 Spline Shaft, Black .....	991.99 ea.
FR30009SS	1969-1974, 1" 48 Spline Shaft, Polished..	1187.99 ea.

**Flaming River Steering Column Installation Accessories**

FRCA100	1964-66 Install Kit.....	345.99 kit
FRCA101	1967-68 Install Kit.....	285.99 kit
FRCA102	1969-72 Non-Key Column Install Kit.....	285.99 kit
FRCA110	1969-72 Key Column Install Kit .....	141.99 kit
FR20300	1969-72 Stramp Clamp.....	68.99 ea.
FR20101CH	1964-67 Floor Mount.....	148.99 ea.
FR20101AB	1968-72 Floor Mount.....	145.99 ea.
FR20118	All Wiring Adapter .....	23.95 kit



**Flaming River Column Kits**

Upgrade your old worn out steering column with this Ground Up Exclusive Flaming River tilt column kit!

FR-F69K-P	1969-74 Tilt Paintable.....	1070.07 kit
FR-F69K-BK	1969-74 Tilt Black .....	1154.67 kit
FR-F69K-PL	1969-74 Tilt Polished .....	1331.07 kit

No volume discount.



FR305FS

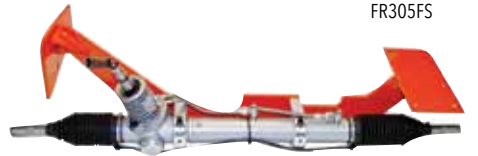

FR305KTPW

**Flaming River Rack And Pinion Conversion Kits**

The Quick Ratio Rack and Pinion Cradle Systems are a great upgrade. The true fixture welded mounting cradle fits between the frame rails and bolts in place using the original chassis location. The system installs easily using simple hand tools and provides Full Turning Radius with a much more responsive steering system than the original.

**Manual Kits Rear Steer**

FR305NC	1962-67 No Column .....	1013.95 kit
FR305KT	1962-67 Paintable Column .....	2230.99 kit
FR305KTPL	1962-67 Polished Column .....	2507.99 kit

**Manual Kits Front Steer**

FR305FSNC	1962-67 No Column .....	3114.99 kit
FR305FS	1962-67 Paintable Column .....	3579.99 kit
FR305FSMPL	1962-67 Polished Column .....	2847.99 kit

**Power Kits Rear Steer**

FR305KTPW	1962-67 Paintable Column .....	3279.99 kit
FR305KTPWPL	1962-67 Polished Column .....	2237.95 kit
FR305KTPWBK	1962-67 Black P/C Column .....	3370.99 kit
FR1610	Hose and Fitting Kit.....	364.99 kit

No volume discount. Not eligible for free shipping.



AAS-300112

AAS-AFBFHS

**Aldan American Coil Over Kits**

Aldan Road Comp kits are designed to convert your suspension to coil-overs. Aldan Phantom Series, single adjustable coil-overs deliver superior handling and ride quality for a drastic improvement over stock suspension. Aldan High tensile, high travel coil-springs provide greater consistency over stock springs. Aldan's rear bolt-on shock absorber kit includes 2 TrueLine Series shocks, 2 brackets, 2 T-Bars and hardware. Uses OEM shock mounting locations. TrueLine adjustable shock absorbers are designed to work with factory and aftermarket springs to add a more consistent, smoother ride.

**Complete Front & Rear Kits**

AAS-300176	1962-67 SB.....	1342.99 kit
AAS-300177	1962-67 BB .....	1342.99 kit
AAS-300112	1968-74 SB.....	910.99 kit
AAS-300113	1968-74 BB .....	910.99 kit

**Front Coil Over Kits**

AAS-300174	1962-67 450lb Springs .....	949.99 kit
AAS-300175	1962-67 550lb Springs.....	949.99 kit
AAS-AFBFMS	1968-74 450lb Springs .....	518.99 kit
AAS-AFBFHS	1968-74 550lb Springs .....	518.99 kit
AAS-AGFMS	1975-79 450lb Springs .....	518.99 kit
AAS-AGFHS	1975-79 550lb Springs .....	518.99 kit

**Rear Shock Kits**

AAS-300178	1962-67 All .....	392.99 kit
AAS-100110	1968-74 All .....	392.99 kit
AAS-100113	1975-79 All .....	392.99 kit

**Parts & Tools**

Thrust bearings aka Torrington bearings make it easier to adjust spring tension and ride height when installed at the base of a coil spring and coilover spring seat. Includes 2 thrust bearings and 4 steel washers. 2.5 in. inner diameter, 3.225 in. outer diameter.

AAS-ALD-27	Bearings & Spanner Wrench.....	67.99 kit
AAS-ALD-26	Bearings Only .....	39.99 kit
AAS-ALD-1	Spanner Only .....	28.99 ea.



APS-6153

**Concourse Series "Banjo" Style Power Steering Pumps**

These are brand new banjo style power steering pumps with correct reservoir, inlet and outlet fittings.

**NO CORE CHARGE!**

APS-6086	1967-68 All V8 .....	175.95 ea.
APS-6153	1969 SB .....	179.95 ea.
APS-6151	1969 BB .....	179.95 ea.
APS-6165	1970-72 All V8 .....	179.95 ea.

*No Volume Discount*



APS-6000R

**Power Steering Pumps Replacement Style**

Completely rebuilt second design power steering pumps. These pumps will differ in appearance from our originals, but will fit and function the same. **NO CORE CHARGE!**

APS-6000R	1969-74 All .....	99.95 ea.
-----------	-------------------	-----------

*No volume discount.*



ADR-077

**Power Steering Pump Cap**

Your choice of black plastic or metal power steering pump cap.

ADR-077	All Plastic .....	8.95 ea.
---------	-------------------	----------



APC-42

**OE Power Steering Pump Cap**

OE style reproduction metal cap.

APC-42	1962-68 .....	19.95 ea.
--------	---------------	-----------



ASP-509

**Power Steering Pump Pulleys**

ADP-61	1968 BB Driver .....	44.95 ea.
ASP-509	1962-74 1 Groove .....	36.95 ea.
ASP-3847	1968 1 Groove, SHP 396/375, 427 .....	155.95 ea.
ASP-107	1969-74 2 Groove w/ AC .....	44.99 ea.
ASP-1395	1969-74 1 Groove SHP .....	49.99 ea.
23-28	Pulley Nut .....	3.95 ea.



AFP-513

CPF-580

**Power Steering Pump Fitting**

OE style reproduction of the very difficult to find power steering pump fitting which is usually missing on remanufactured pumps.

CPF-580	1962-79 All .....	11.99 ea.
AFP-513	1967-69 All .....	34.95 ea.

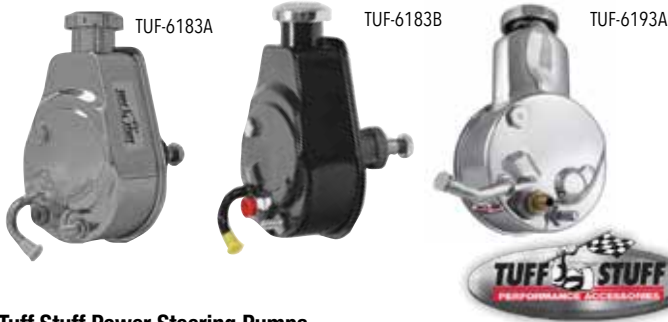

**Tuff Stuff Power Steering Pumps**

GM Saginaw style pumps feature all new components reservoir, pump assembly, cap & dipstick and hardware when it applies. Rated at 1200 PSI rated to work with most gearbox systems.

TUF-6197A	1968 All Chrome Banjo Style .....	235.99 ea.
TUF-6197B	1968 All Black Banjo Style .....	186.99 ea.
TUF-6198A	1969 Non V8 Chrome Banjo Style .....	235.99 ea.
TUF-6198B	1969 Non V8 Black Banjo Style .....	186.99 ea.
TUF-6191A	1969 SB Chrome Banjo Style .....	235.99 ea.
TUF-6191B	1969 SB Black Banjo Style .....	186.99 ea.
TUF-6195A	1969 BB Chrome Banjo Style .....	235.99 ea.
TUF-6191B	1969 SB Black Banjo Style .....	186.99 ea.
TUF-6193B	1970 All V8 Black Banjo Style .....	186.99 ea.
TUF-6183A	1970-74 All V8 Chrome .....	221.99 ea.
TUF-6183B	1970-74 All V8 Black .....	174.99 ea.
TUF-5559	Universal Inline Filter .....	32.99 ea.

*No volume discount.*



PSKIT-69FBB

**BUY'N SAVE WITH KITS**

**Power Steering Conversion Kits**

Are you tired of getting a workout every time you want to turn a corner? Ground Up makes it easy to convert to power steering with these power steering conversion kits! We have taken all the guesswork out of selecting the parts required to convert with this all in one solution. Includes: Banjo style pump, Pump cap, Brackets, Hardware, Pulley nut, Pressure hose and the return hose kit.

PSKIT-69FSB	1969 SB w/o AC .....	314.86 kit
PSKIT-69FSBAC	1969 SB w/ AC .....	321.30 kit
PSKIT-69FBB	1969 BB w/o AC .....	282.87 kit
PSKIT-69FBBAC	1969 BB w/ AC .....	289.30 kit
PSKIT-702XSB	1970-72 SB w/o AC .....	307.67 kit
PSKIT-702XSBAC	1970-72 SB w/ AC .....	314.10 kit
PSKIT-702XBB	1970-72 BB w/o AC .....	275.68 kit
PSKIT-702XBBAC	1970-72 BB w/ AC .....	282.11 kit

*These kits fit engines with a long water pump.*

*No volume discount.*

**Power Steering OEM High Pressure Hose**

New correctly bent OEM high pressure hoses with correct fittings.



ARK-62X 1962-67 All V8 .....89.99 pr.



CPX-6616 1968 All V8.....26.95 ea.



CPX-6602 1969 All V8.....26.95 ea.



CPX-584 1970-79 6 Cyl .....27.95 ea.  
 CPX-586 1970-72 All V8 .....29.95 ea.



CPX-577 1973-74 All V8 .....27.95 ea.



**BUY'N SAVE WITH KITS**



ARK-678F

**Power Steering Hose Kits**

This kit comes with OEM high pressure hose, low pressure return tube, hose and correct clamps

ARK-678F	1968 All V8 .....	38.17 kit
ARK-69F	1969 All V8 .....	39.96 kit
ARK-586	1970-72 All V8.....	40.72 kit
ARK-577	1973-74 All V8.....	39.02 kit

No Volume Discount

NPX-16



**Power Steering Return Hose**

Complete with correct pre-bent flared tube, OEM hose and correct clamps.

NPX-16	1964-72 All V8 .....	17.95 kit
CPS-038	OEM Return Hose .....	2.95 pr. ft
CPN-512	OEM Clamps Screw Type .....	1.95 ea.

BSB-1970



**Power Steering Hardware Kits**

Our kits feature all correct hardware to attach power steering brackets to engine. A MUST!

G-4804	1967 SB (13 pc.) .....	16.99 kit
G-4805	1967 BB (13 pc.).....	16.99 kit
G-4917	1968 SB 327 (14 pc.) .....	16.99 kit
G-4918	1968 BB 396 (13 pc.).....	16.99 kit
BSB-69SB	1969-72 All SB.....	12.99 kit
BSB-1969	1969 BB .....	19.99 kit
BSB-1970	1970-72 All BB.....	12.95 kit

ASC-128



**Power Steering Hose Retaining Clip**

Correct clip for retaining hose to steering box.

ASC-128	All V8.....	12.95 ea.
---------	-------------	-----------

**Power Steering Brackets**

Original style reproduction and original GM brackets.



ASB-366

ASB-366 1965-68 SB Cradle.....49.95 ea.  
For use with short water pump.

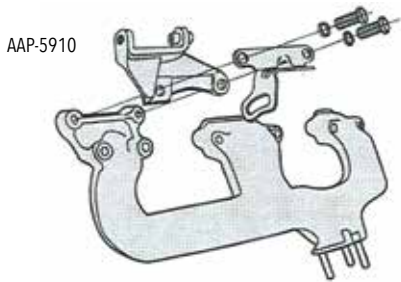

AAP-5910

AAP-5910 1964-68 SB Upper Adjustor (to manifold)..... 29.95 ea.  
For use with short water pump. Not for use with Ramshorn exhaust manifolds.



ASB-383

ASB-383 1966-67 L-79.....39.95 kit  
For use with short water pump.



ASB-184

ASB-184 1968 SS396 Cradle.....64.99 ea.  
For use with short water pump.



ASB-186

ASB-186 1968 396 Adjustor.....39.99 ea.  
For use with short water pump.



AQW-1418

AQW-1418 1969 All BB (3 piece) ..... 64.99 kit  
Works with original long water pump & P/S pump.



ASB-3941

ASB-3941 1969-74 All SB Cradle..... 25.95 ea.  
For use with long water pump.



ASB-874

ASB-874 1969-74 SB Rear Support.....35.95 ea.  
For use with long water pump.



AAB-2610

AAB-2610 1969-76 SB Adjustor.....35.95 ea.  
For use with long water pump.



ASB-422

ASB-422 1969-74 All BB Cradle.....32.95 ea.  
For use with long water pump.



ASB-931

ASB-931 1969-74 All BB (adjuster).....24.95 ea.

**BUY'N SAVE WITH KITS**



ASB-7KIT

**1970-74 Big Block Power Steering Bracket Kit**

Complete kit with cradle, adjustment brackets and hardware.

ASB-7KIT 1970-74 All BB\* ..... 63.77 kit  
Will work on most BB engines with long pump. May need some modification.



ASB-9KIT

**1969-72 Small Block Power Steering Bracket Kit**

Complete kit with all three brackets.

ASB-9KIT 1969-74 SB ..... 88.07 kit

**BUY'N SAVE WITH KITS**



GBK-1F

**Power Steering Gearbox Kits**

Now you can add on one of these awesome "close ratio" gear boxes to get better handling out of a stock style box. Our kit comes with steering box, steering coupler (rag joint) and correct attaching bolts. Will fit 68-74 Nova.

**NO CORE CHARGE!**

GBK-1F 3 - 3.5 Fast..... 293.14 kit  
 GBK-1SFA 2.5 Super Fast ..... 326.33 kit  
 No volume discount. Ships UPS Oversized  
 Note: Saginaw 600 Gear Box.

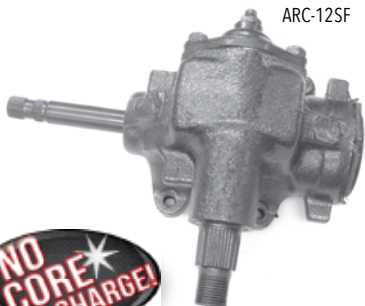

ARC-12SF

**Manual Steering Boxes**

Complete remanufactured original Saginaw assemblies. Choose from standard or quick ratio. **NO CORE CHARGE.**

ARC-12A 1968-69 24:1 Std.....289.95 ea.  
 ARC-12B 1970-74 24:1 Std.....289.95 ea.  
 ARC-12SF 1968-74 16:1 Quick..... 309.95 ea.

Note: Use ATE-8869B coupler with ARC-12SF.  
 No volume discount. Ships UPS Oversized.



D-1870

**Pitman Arm**

OEM pitman arm.

**Manual Steering**

DA-985 1968-74 ..... 75.95 ea.

**Power Steering**

D-1870 1968-72 ..... 69.95 ea.  
 DPA-73 1973-74 ..... 65.95 ea.



BX-64K

**Pitman Arm Nut**

Correct nut with washer.

BX-64K 1968-74 ..... 6.95 ea.

ATE-8871



**Steering Coupler**

Complete joint for connecting column to box. 1968-69 with manual steering features fine spline and 1970-74 with manual steering features coarse spline.

ATE-8869A 1968-69 Manual..... 49.95 ea.  
 ATE-8869B 1970-74 Manual..... 49.95 ea.  
 ATE-8871 1968-74 Power..... 49.95 ea.



ATJ-411

**Steering Coupler Bolt**

Correct OEM bolt for coupler.

ATJ-411 1968-74 All .....6.99 ea.



BSB-757

**Steering Box Bolt**

Complete with correct thick washer and bolt.

BSB-757 1968-74 All ..... 4.99 ea.



DSE090204

**600 Steering Gear**

DSE's 600 steering gearbox provides you with rack and pinion performance with a bolt-in steering gear. Choose from paintable finish or ceramic coated.

- All new, not rebuilt!
- Increased steering feel due to low friction gear design!
- Precision rack and pinion valve technology!
- Late model performance car feel!
- Quick ratio 12.7:1!
- Original power pitman arm may be used!
- 6 pounds lighter than stock!

DSE090204 1968-74 Bare .....794.99 ea.  
 DSE090204C 1968-74 Coated ..... 1093.95 ea.

Note: Part number DSE 090205 rag joint and DSE 091202 hose kit are required with this box. Ships Oversize. No Volume Discount.

DSE090205



**DSE Steering Coupler**

Correct steering coupler for use with 600 box.

DSE090205 1968-74 .....98.99 ea.  
 No Volume Discount



DSE091202

**DSE Power Steering Hose Kit**

Includes fittings to convert your steering gear to -6 AN fittings. High quality stainless steel hoses are Teflon lined to handle the high pressure demands of the steering system. The hoses come with pre-cripped stainless steel fittings to attach to the -6 AN fittings at the steering gear. Each kit includes 30 inches of hose length that can be routed and cut to length at the pump end.

DSE091202 1968-74 ..... 194.99 kit  
 No Volume Discount