

FUEL TANKS

XTR-70A

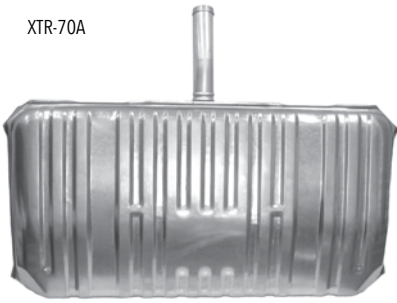

Fuel Tanks

The same fuel tanks in our kits above available separately.

OEM Tanks

XT-70A	1970-72 w/o EEC	219.99 ea.
XT-70E	1970-72 w/ EEC	219.99 ea.
XTR-306A	1987-88 17 Gal Carb	169.99 ea.
XTR-306C	1985-88 17 Gal Fuel Injection	169.99 ea.

Import Tanks

High quality shiny zinc plate Imports, great quality at a great price.

XTR-70A	1970-72 w/o EE	139.99 ea.
XTR-70E	1970-72 w/ EEC	139.99 ea.

Ships Oversize 2. Not eligible for free shipping.

XTS-70A



Stainless Steel Fuel Tanks

These stainless steel fuel tanks are shiny enough for any show car and rust proof enough for any daily driver! Installation is easy because this tank is a direct Bolt-in replacement for your OEM tank.

XTS-70A	1970-72 w/o EEC	239.99 ea.
XTS-70E	1970-72 w/ EEC	239.99 ea.

Ships Oversize 2. Not eligible for free shipping.



HOL-19-107



HOL-19-444



HOL-526-10

1970-88 Sniper Fuel Injection Fuel Tanks

Converting the carbureted fuel system on your car or truck over to EFI can be a daunting task. We have made this conversion easy with our complete tank and fuel system kits! The heart of a fuel system begins with the fuel tank. When converting to EFI, it is crucial that you do not contaminate your new parts with dirt, rust, and sludge from an old fuel tank. Sniper fuel tanks are designed to meet or exceed the quality of your factory fuel tank. Sniper tanks are made from steel with a galvanized finish that are manufactured to the OEM specifications for your Monte Carlo.

HOL-19-107	1970-72 550HP	611.99 ea.
HOL-19-407	1970-72 750HP	662.99 ea.
HOL-19-144	1978-88 550HP	593.99 ea.
HOL-19-444	1978-88 750HP	649.99 ea.
HOL-526-10	1970-77 EFI Fuel System Install Kit.....	237.99 ea.

No Volume Discount. Ships Oversize. Not eligible for free shipping.

XTC-149



XTC-33

Fuel Tank Caps

OEM caps designed to work with original tanks only. Repro caps designed to work with import tanks only.

XTC-149	1970-72 OEM Vented	11.95 ea.
XTC-33	1970-72 OEM Non-Vented	9.95 ea.
XTC-06	1970-72 Import Tank	9.95 ea.
XTC-06	1970-74 Deep Tangs	9.95 ea.

NH-4381



Fuel Tank Insulation

Correct foam insulation which is glued to the top of the fuel tank to prevent squeaks and rattles, and tar paper which goes between the tank and the straps.

NH-4381	1970-72 All	13.99 kit
NH-UNI	All Universal 36x21" Pad	19.99 ea.

FUEL TANK HARDWARE



BPX-4755

Fuel Tank Hardware

Correct OEM bolts and clips.

BPX-4755	1970-72 All	12.95 kit
----------	-------------------	-----------



XTD-1630

BTB-56



XTD-10B



Fuel Tank Door

Correct spring loaded fuel tank door.

XTD-1630	1970-72 Door	22.95 ea.
XTD-10B	Door Bumper	1.95 ea.
BTB-56	Door Bolt.....	1.25 ea.



ELC-516



ELC-1438T



BLC-056

Fuel Line Clips

Correct clips for attaching fuel lines to frame.

ELC-1516	5/16" Line	3.99 ea.
ELC-516	5/16" w/ Tab	3.99 ea.
ELC-038	3/8" Line	4.99 ea.
ELC-1438	1/4" - 3/8" Line.....	4.99 ea.
ELC-1438T	1/4" - 3/8" w/Tab.....	3.99 ea.
BLC-056	Correct Bolt	0.50 ea.



AXP-3800

AXP-1438

Fuel Tank Hose Kits

Correct GM hose and pinch clamps.

AXP-3800	All 3/8"	4.95 kit
AXP-1438	All 3/8" - 1/4"	6.95 kit

FUEL FILTER



AAC-427



AAC-455

Fuel Filters

Original GM AC Delco

AAC-427	Q-Jet Short Style	4.95 ea.
AAC-455	All Holley Brass	5.99 ea.



HOL-12834

Holley Chrome Fuel Pumps

Mechanical pumps designed to work with stock or mildly modified engines. Free-flow output of 80 GPH (SB) or 80-130 GPH (BB). Body castings can be rotated 360-degrees to ease mounting in difficult places. Heavy duty construction can withstand long periods at high RPM. 1/4" (SB) 3/8" (BB) pipe thread inlet and outlet ports.

HOL-12834	Small Block.....	93.99 ea.
HOL-12835	Big Block.....	93.99 ea.

Note: Not compatible with methanol or alcohol. Cannot be used with fuel injection systems.



QF-30-350QFT

Quick Fuel Technology Fuel Pumps

For the street cruiser, it's tough to beat the simplicity and reliability of a mechanical fuel pump. Quick Fuel Technology's mechanical pumps flow 110 gallons per hour and utilize lightweight aluminum housings. They feature integrated shutoff valves that are preset at 6.5- to 8 psi, eliminating the need for a separate pressure regulator. For added installation flexibility, the pump casting can be rotated to accommodate various plumbing configurations. 3/8" NPT threads. Gasoline only.

QF-30-350QFT	Small Block	101.99 ea.
QF-30-454QFT	Big Block	110.99 ea.

No Volume Discount.



QF-30-125-1QFT



Quick Fuel Technology Electric Fuel Pumps

QFT's electric fuel pumps are perfect for combinations that are neither stock nor all out race cars. These pumps flow more than enough fuel to support between 400-750 hp. Mounting hardware and brackets are included.

- 125 GPH Flow Rate
- 14 PSI Maximum Pressure
- Features 3/8" NPT Inlets and Outlets
- Draws 4 Amps or Less at Full Load
- For Carbureted Gasoline Applications Only

QF-30-125-1QFT	Pump Only	117.99 ea.
QF-30-125-1RQFT	Pump/Regulator.....	134.99 ea.

No Volume Discount.



HOL-12-426

Holley Electric Fuel Pumps

Holley is proud to introduce the all new Holley Mighty Mite™ electric fuel pumps! They're big on performance, but small in size! They're quiet, easy to install and work with gas, diesel, blended alcohol and E85!

12 volt operation. 25 gal/hr flow. Good for up to 300HP naturally aspirated. Simple 2 wire hookup. Self-priming and regulating. Quiet operation - 65db. Hose barbs fit 5/16" Fuel Hose. Made in the USA

HOL-12-426	All 25 GPH 1.5-4 PSI.....	50.99 ea.
HOL-12-427	All 32 GPH 4-7 PSI.....	50.99 ea.

No Volume Discount.



HOL-12-803BP

Holley Fuel Pressure Regulator

Holley fuel pressure regulators are designed to precisely control the fuel pressure from the fuel pump to the carburetor. Too much fuel pressure for a given needle and seat assembly will overload and may cause flooding or drivability problems. Each Holley fuel pressure regulator is fully adjustable so regulating the fuel pressure to your engine's needs is simple.

12 volt operation. Preset to 7psi. 3/8" NPT ports (1 in, 1 out, 1 bypass or return). Used in systems with a return line back to the fuel tank

HOL-12-803BP	All Carbureted.....	88.99 ea.
--------------	---------------------	-----------

No Volume Discount.



GCS-S4297

GCS-S9245

GCS-S9407

GCS-S9177

Chrome Inline Fuel Filters

Choose from a variety of show quality chrome fuel filters to dress up your engine.

Carburetor

GCS-S9407	Bronze Element, 3/8", Chrome.....	10.99 ea.
GCS-S9177	Paper Element, 3/8", Chrome.....	7.99 ea.
GCS-S9177BK	Paper Element, 3/8", Black.....	7.99 kit
GCS-S9245	Glass Element, 3/8", Chrome.....	10.99 ea.
GCS-S9212BK	Paper Element, 5/16", Black	7.99 ea.

Not for fuel injection.

Red Top High Capacity Chrome Fuel Filters

Show quality chrome plated fuel filter with paper element and pipe fittings.

GCS-S4297	Small.....	39.99 ea.
GCS-S4295	Large.....	39.99 ea.



ACE-395



ACE-4867

ACE-9599

Fuel Pump Hardware

AJE-395	All Activating Rod	14.95 ea.
ACE-9599	All SB Plate.....	10.99 ea.
ACE-4867	Fuel Pump Bolts.....	7.95 kit



AXP-3800

AXP-6400

Fuel Pump Hose Kit

Correct GM hose for connecting fuel pump to main fuel line. Complete with correct "colored" pinch clamps.

AXP-3800	All 3/8" (3 pc.).....	4.95 kit
AXP-1438	All 3/8"-1/4" (6 pc.).....	6.95 kit
AXP-6400	All 3/8" 90 degree bend	11.95 kit



AFT-238

Fuel Line Brace

Correct factory installed brace for carb line.

AFT-238	1970 L-78, LS-6.....	15.95 ea.
---------	----------------------	-----------

EXHAUST MANIFOLDS

AXD-69



Exhaust Manifolds SB

New GM restoration manifolds. These brand new manifolds are sold in matched pairs and come with GM cast numbers.

AXD-69	1970-72 SB non-SMOG 3932376 / 3942529	359.95 pr.
AXD-69S	1970-72 SB with SMOG 3946826 / 3942527	379.95 pr.

No Volume Discount. Ships Oversize. Not eligible for free shipping.

AXD-396



Exhaust Manifolds BB

New GM restoration manifolds. Sold in matched pairs with GM cast numbers (3909879-3916178). Correct for most Monte Carlos.

AXD-396	BB non-SMOG 3916178 / 3909879	379.95 pr.
AXD-396S	BB with SMOG 3916178 / 3909879	379.95 pr.

No Volume Discount. Ships Oversize. Not eligible for free shipping.



EHS-128



EHS-471



EHS-473

Upper Heat Stove

Works in conjunction with the air heat tube to preheat the air cleaner thermo-sensor. This item mounts on the right hand (passenger side) exhaust manifold. Manufactured to original specifications featuring the correct zinc plating.

EHS-471	1970-76 Small Block	9.99 ea.
EHS-473	1970-77 V8	19.99 ea.
EHS-128	1970-77 Heat Stove Tube.....	13.99 ea.



Exhaust Gaskets & Donuts

XG-20	Riser Gasket 2" SB.....	1.95 ea.
XG-225	Riser Gasket 2.5" BB	1.95 ea.
XD-400	Donut 2" SB.....	3.95 ea.
XD-500	Donut 2.5" BB.....	4.95 ea.
XE-152	Extension 2" SB.....	12.99 ea.
XE-153	Extension 2.5" BB	15.99 ea.
GCS-S7501	Collector Gaskets, 2.5"	21.99 kit
GCS-S7502	Collector Gaskets, 3"	21.99 kit
GCS-S7503	Collector Gaskets, 3.5"	21.99 kit
GCS-S7504	SB Manifold Gaskets	32.99 kit
GCS-S7507	BB Manifold Gaskets, Round Port	42.99 kit
GCS-S7508	BB Manifold Gaskets, Rectangle Port	42.99 kit

ALI-2228



Exhaust Stud Kit

Correct studs for mounting exhaust pipe to manifold. Our kit comes complete with 3 long & 3 short studs and 6 correct locking nuts.

ALI-2228	All SB - BB.....	24.99 kit
----------	------------------	-----------



Heat Riser Valves

Correct valve for pre-heating engine on cold start.

AHR-1190	Valve SB 2".....	49.95 ea.
AHR-1180	Valve BB 2.5".....	69.99 ea.



N-660

Heat Riser Spacers

Takes the place of the heat riser for increased flow.

N-660	Spacer SB	54.95 ea.
N-733	Spacer BB.....	46.99 ea.

APB-1382



OEM Exhaust Manifold Bolts

Correct head marked and colored bolts for mounting exhaust manifolds to block.

APB-1382	SB w/ Washers (24 pc.).....	27.99 kit
APB-1821	BB Flanged Head (16 pc.).....	23.99 kit
APB-3506	BB Loose Washer (32 pc.).....	26.99 kit



EXL-200

Exhaust French Locks

This kit is a correct set of four stainless steel stamped french locks for corners of exhaust manifold as installed by factory.

EXL-100	1970-77 SB	14.95 kit
EXL-200	1970-73 BB*.....	14.95 kit

**Not for flanged bolts.*

XET-321



Detail

Exhaust Tips Stock

Reproduction exhaust tips featuring correct GM part numbers for your 1970-72 Monte Carlo SS. Beautiful triple chrome finish.

XET-321	1970-72 2.5" w/ Numbers.....	59.95 pr.
NX-766	1970-72 2.5" w/o Numbers.....	49.95 pr.
XET-3213	1970-72 3" w/ Numbers	59.95 pr.
NX-7663	1970-72 3" w/o Numbers.....	49.95 pr.

No Volume Discount.



EVT56



EVT49

Pypes Exhaust Tips

Add the finishing touch to your exhaust system with a set of triple chrome plated tips from Pypes! All tips are slip fit.

EVT54	2.5" OE style.....	100.99 pr.
EVT56	3" OE style.....	115.99 pr.
EVT49	2.5" Angle Cut.....	38.99 pr.
EVT50	3" Angle Cut.....	48.99 pr.

EXHAUST SYSTEMS

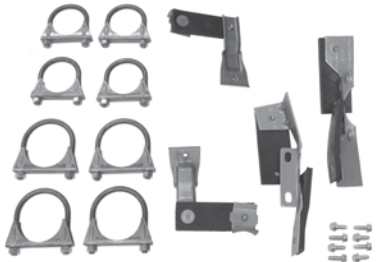

XHP-642

Exhaust Hanger Kits

Complete with all necessary hardware to install your new OEM style exhaust system.

XHP-642 1970-72 OM 89.99 kit



DGU14S

Downpipes

If you are using stock manifolds, you will need a pair of these downpipes to connect to the system. 409 Stainless steel.

DGU14S 1970-77 SB 152.99 pr.
DGU20S 1970-77 BB 140.99 pr.



PVR10S

Collector Reducers

These act as connectors from your header collectors to intermediate pipes for a clean look.

PVR10S 3" Header to 3" Pipe 84.99 pr.
PVR13S 3.5" Header to 3" Pipe 84.99 pr.
PVR16S 3" Header to 2.5" Pipe 84.99 pr.
PVR19S 3.5" Header to 2.5" Pipe 84.99 pr.



Turn Downs

These universal downturns are perfect for off road applications when tail pipes are not desired.

PVD10 2.5" 409 Stainless 59.99 pr.
PVD13 3" Aluminized 72.99 pr.

XMH-64A

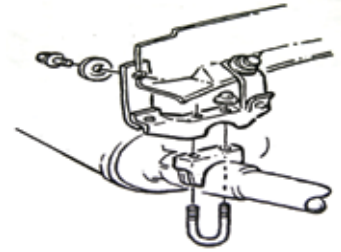

XPH-69CH

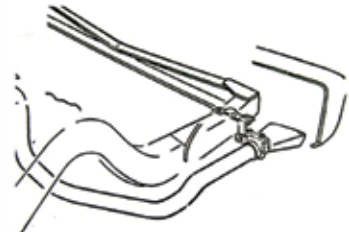

XPH-70CH

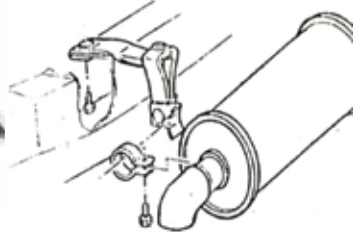

XPH-68CH

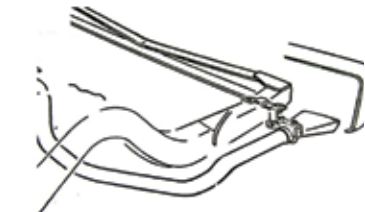

XPH-70SS

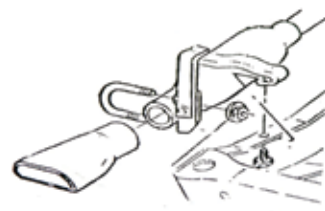

Exhaust Hangers

Factory reproduction exhaust hangers are a great way to finish off your restoration. Can be used with exhaust size 2 inch, 2^{1/4} inch, 2^{1/2} inch or larger.

XMH-64A 1970-72 Muffler Hanger 51.99 pr.
XPH-69CH 1970-72 Tail Pipe Hanger 41.99 pr.
XPH-70CH 1970-72 Tail Pipe Hanger 41.99 pr.
XPH-68CH 1970-72 Tail Pipe Hanger 41.99 pr.
XPH-70SS 1970-72 Tail Pipe Hanger* 61.99 pr.

* Correct for LS3, LS5 and LS6 Super Sport



HKR-11051HKR

Hooker Dual Exhaust Cut-Out Kits

The choice is yours – Tease the Street or Please the Track with Hooker's new "Street-Tease" exhaust cut-outs! Good and "old" ideas improved with new materials, that's what we have here! These cut-outs will provide years of worry free use with a mixture of stainless steel and aluminum. The materials will keep the elements out, and the sound, well that's up to you, with a flip of the toggle or a push of the remote button.

- TIG-welded T-304 stainless steel tubing for a clean and weather resistant finish
- 6061 aircraft aluminum motor and valve bracket
- Instant performance gains when opened
- Stainless tip can be positioned for any direction of exhaust
- Simple 12v cigarette lighter plug-in for main power supply
- Welding Required

HKR-11051HKR	Dual 2.5" Kit.....	434.99 kit
HKR-11052HKR	Dual 3" Kit.....	434.99 kit

No Volume Discount.



HKR-8501-1HKR

HKR-8501-4HKR

HKR-8501HKR

Hooker Cast Iron LS Exhaust Manifolds

Hooker cast iron exhaust manifolds have been designed to hug close to the engine block so they fit into a wide variety of replacement and engine-swap applications. Their contoured design aims the exhaust directly at the exit port for improved flow. Being cast iron means they will provide years of leak-free performance with less under hood noise than traditional headers. Plus, their shorty design means you can route exhaust tubing close to your frame/floor pan for maximum ground clearance. "Hook" up your GM LS engine with Hooker cast iron manifolds today!

- Intended for all GM LS (except LS7 and LS9) engine swap applications where durability, quiet operation, emissions compliance and leak-free sealing is desired
- Cast from Hi-Silicon-Moly Ductile Iron to provide durability and corrosion resistance
- 2.25-inch outlet diameter
- Free-flowing for good performance and catalytic converter efficiency
- Recommended for strong performance on engines making up to 500 horsepower



HKR-8501-1HKR	Silver Ceramic Coated	440.99 kit
HKR-8501-3HKR	Black Ceramic Coated.....	440.99 kit
HKR-8501-4HKR	Titanium Ceramic Coated.....	440.99 kit
HKR-8501HKR	Natural Cast Finish	330.99 kit
HKR-8510HKR	Natural Cast Finish Turbo*.....	487.99 kit

*For use with a turbo charger. No Volume Discount.



FLOW-17119

Flowmaster American Thunder Dual Exhaust Systems

With easy fit in mind, these systems are mandrel bent for maximum performance and include specially selected mufflers. American Thunder systems deliver a moderate to aggressive interior and exterior tone.

- Mandrel bent 16 gauge aluminized tubing
- Includes hangers and hardware for easy installation
- Made in the USA

Below includes Super 40 Series Mufflers; Moderate to Aggressive Sound

FLOW-17119	1970-72, 2.5", Aluminized, Dual Rear Exit.....	561.99 kit
------------	--	------------

Below includes Super 40 Series Mufflers; Aggressive & Powerful Sound

FLOW-817409	1970-72, 2.5", Stainless, Dual Rear Exit.....	635.99 kit
FLOW-17200	1970-72, 3", Aluminized, Dual Rear Exit.....	703.99 kit
FLOW-817200	1970-72, 3", Stainless, Dual Rear Exit.....	856.99 kit



FLOW-15819

Flowmaster Pre-Bent Tail Pipes

These 16 gauge mandrel bent pipe kits are designed to fit perfectly onto your vehicle with all the quality and performance that you would expect from Flowmaster.

- Premium Flowmaster Quality
- Mandrel bent 16 Gauge Tubing • Rear Exit

Aluminized Steel

FLOW-15802	1970-72 2.5" Rear Exit	159.99 pr.
FLOW-15818	1970-72 3" Rear Exit	183.99 pr.
FLOW-15819	1970-72 3" Rear Exit	173.99 pr.
FLOW-15817	1978-88 3" Rear Exit	153.99 pr.

409 Stainless Steel

FLOW-815802	1970-72 2.5" Rear Exit.....	204.99 pr.
-------------	-----------------------------	------------

No Volume Discount.



FLOW-81068

Flowmaster Downpipes

Flowmaster's manifold downpipe kits are designed for the person who wants to use a Header-back exhaust system while using the factory exhaust manifolds. Utilizing mandrel bent 409S stainless steel tubing and high quality flange gaskets, Flowmaster's manifold downpipe kits are designed for the perfect leak free fit.

- Pipes designed to be used without heat riser
- 2.50 in manifold downpipe
- Mandrel bent 16 gauge 409 stainless steel tubing

FLOW-81068	1970-74 Small Block.....	157.99 kit
FLOW-81071	1970-74 Big Block	157.99 kit

No Volume Discount.



FLOW-814111

Flowmaster Scavenger Series Elite Shorty Headers

Flowmaster's Scavenger Series Elite shorty headers are designed to replace the restrictive factory manifolds. These high quality headers are manufactured from stainless steel and are ceramic coated for maximum durability. They feature 1-3/4 in primary tubes, 3/8 in thick laser cut flanges and factory collector connections, ensuring a direct-fit, leak free installation. Like all Flowmaster products, the benefits include improved throttle response, power and engine efficiency.

- 3/8" laser cut flanges
- Dyno tuned for maximum performance
- High temperature ceramic coating
- 409 stainless steel construction



FLOW-814111 1970-77 Big Block 1-3/4" Primary.....732.99 kit
No Volume Discount.



FLOW-814110



FLOW-814114

Flowmaster Scavenger Series Elite Long Tube Headers

Scavenger Series Elite long tube headers deliver maximum performance and are suited to the enthusiast who wants the best. Like all Flowmaster products the benefits include improved throttle response, power and engine efficiency. Designed for an easy fit these headers include gaskets and necessary hardware for easy installation.

- Ball & socket collector
- Ceramic coated
- 0.375 thick laser cut flanges
- 3 inch collector outlet



FLOW-814110 1970-77 SB 1-5/8"732.99 kit
FLOW-814114 1970-74 BB 2"732.99 kit



FLOW-814116

Flowmaster LS Swap Headers

Flowmaster's Scavenger Series Elite headers feature heavy duty 3/8 in laser cut flanges, 16 gauge stainless steel primary pipes and gasket free ball flange exhaust connectors. These full length headers provide an exact fit and increased performance. Please note these headers are not emissions legal and are designed for off-road use only.

- Gasket free ball style collectors
- Ceramic coating
- Stainless steel construction
- Collector included
- Dyno tuned for maximum performance



FLOW-814116 1970-72 All 1-3/4" Primaries, 3" Exit.....732.99 pr.
No Volume Discount.



FT-11108FLT

Flowtech Mid-Length Headers

Flowtech headers are the perfect combination of performance and value. Flowtech Mid-Length headers are precision engineered using mandrel bent tubing, formed collectors and 5/16" flanges with sealing rings for a leak-free seal.

- Tuned-length primary tubes for street performance
- Mandrel-bent tubing for smooth exhaust flow
- Light weight & sturdy 16 gauge tubing
- Mandrel-formed Power Plenum collector for low back pressure
- Sturdy, leak-tested O-Ring port seals
- Engineered for an easy, trouble-free precision fit
- Includes all mounting hardware and premium gaskets



Small Block

FT-11108FLT 1970-88 Black Paint 1-1/2" Tubes 2.5" Collector.....169.99 pr.
FT-11102FLT 1978-88* Black Paint 1-1/2" Tubes 2.5" Collector.....174.99 pr.

*Features O2 oxygen sensor bung. No Volume Discount.



FT-49100FLT

Flowtech Afterburner Headers

Flowtech's Afterburner Turbo Chamber Headers represent the first new major design change in exhaust technology in decades. This design combines the race-proven 4 into 1 design with the torque managing capabilities of a Tri-Y header. The turbo chamber helps smooth out exhaust turbulence for increased performance and a broad power curve.

- Horsepower and torque increased over conventional header design
- Big 3" secondary collector for reduced back pressure
- Tuned-length primary tubes combine with velocity tube to smooth out exhaust pulses
- All hardware and premium gaskets included for a complete installation
- Patented velocity tube increases cylinder scavenging

FT-49100FLT 1970-88 Black Paint 1-5/8" 3" Collector.....267.99 pr.
FT-49100-1FLT 1970-88 Silver Ceramic 1-5/8" 3" Collector.....453.99 pr.

No Volume Discount.



FT-11100FLT



FT-11000FLT

Flowtech Long Tube Headers

Flowtech headers are the perfect combination of performance and value. Flowtech long tube headers are precision engineered using mandrel bent tubing, formed collectors and 5/16" flanges with sealing rings for a leak-free seal. All mounting hardware and gaskets are included for a simple installation. This header is coated in a high heat resistant black paint for a stealthy appearance. Instant performance gains when opened.

- Tuned-length primary tubes for street performance
- Mandrel-bent tubing for smooth exhaust flow
- Light weight & sturdy 16 gauge tubing
- Mandrel-formed Power Plenum collector for low back pressure
- Sturdy, leak-tested O-Ring port seals
- Engineered for an easy, trouble-free precision fit
- Includes all mounting hardware and premium gaskets



Small Block

FT-11100FLT	1970-88 Black Paint 1-5/8" Tubes 3" Collector.....	171.99 pr.
FT-31100FLT	1970-88 Silver Ceramic 1-5/8" Tubes 3" Collector.....	363.99 pr.
FT-11104FLT	1970-88 Black Paint 1-5/8" Tubes 3" Collector.....	169.99 pr.

Big Block

FT-11130FLT	1970-74 Black Paint 1-3/4" Tubes 3" Collector.....	195.99 pr.
FT-11132FLT	1970-74 Black Paint 1-7/8" Tubes 3.5" Collector.....	228.99 pr.

No Volume Discount.

Flowtech Block Hugger Headers

Flowtech Block Hugger headers are ideal for street rods where fit and finish is really important. Block Huggers make performance and style easy for engine swaps, and with our new Hugger Toobs you can hook up to an existing system with ease.

- Computer-controlled mandrel-bent tubing for smooth exhaust flow
- Sturdy 16 gauge tubing
- Easy installation - can be used with stock motor mounts
- Precision die-cut exhaust port flanges
- Engineered and tested for a leak-proof seal
- All necessary hardware included for a complete installation

Small Block

FT-11000FLT	1970-88 Black Paint 1-5/8" Tubes 2.5" Collector.....	191.99 pr.
FT-31000FLT	1970-78 Silver Ceramic 1-5/8" Tubes 2.5" Collector.....	373.99 pr.

Big Block

FT-11030FLT	1970-88 Black Paint 1-3/4" Tubes 2.5" Collector.....	198.99 pr.
FT-31030FLT	1970-78 Silver Ceramic 1-3/4" Tubes 2.5" Collector.....	502.99 pr.

Big Block Tight Fit

FT-11701FLT	1970-88 Black Paint 1-3/4" Tubes 2.5" Collector.....	233.99 pr.
FT-11701-1FLT	1970-88 Silver Ceramic 1-3/4" Tubes 2.5" Collector.....	347.99 pr.
FT-11701-7FLT	1970-88 Stainless 1-3/4" Tubes 2.5" Collector.....	347.99 pr.
FT-11701-2FLT	1970-78 Chrome 1-3/4" Tubes 2.5" Collector.....	347.99 pr.

No Volume Discount.



HKR-2451HKR

HKR-2455-2HKR

Hooker Competition Headers

Hooker Competition headers offer the best value in the high performance header market. Designed for the value-conscious buyer who is running either a "stock" or "mildly-modified" engine, these headers offer premium features at a very competitive price. Made of durable 16 gauge mild steel tubing, header design utilizes a long transition collector to reduce back pressure and increase exhaust flow. A perfect sealing surface is assured with the 5/16" machined flanges, with welded O-ring seals. Experience has proven that this flange size is ideal to maintain header integrity and be pliable enough to seal each exhaust port. Tubing is mandrel-bent to maintain metal strength and provide consistent tube diameter at radii to maximize performance.

- All necessary hardware included for a complete installation
- Designed for easy, trouble-free fit
- Industry's best welds for durability
- Long transition collector for decreased back pressure
- Tuned-length primary tubes for street performance



Hooker Long Tubes

Small Block

HKR-2451HKR	1970-77 Black Paint 1-5/8" Tubes 3" Collector.....	215.99 pr.
HKR-2451-1HKR	1970-77 Silver Ceramic 1-5/8" Tubes 3" Collector.....	473.99 pr.
HKR-2451-3HKR	1970-77 Black Ceramic 1-5/8" Tubes 3" Collector.....	564.99 pr.
HKR-2451-2HKR	1970-77 Stainless 1 5/8" Tubes 3" Collector.....	685.99 pr.

Big Block

HKR-2455-1HKR	1970-74 Silver Ceramic 2" Tubes 3.5" Collector.....	467.99 pr.
HKR-2455-3HKR	1970-74 Black Ceramic 2" Tubes 3.5" Collector.....	564.99 pr.
HKR-2455-2HKR	1970-74 Stainless 2" Tubes 3.5" Collector.....	758.99 pr.

No Volume Discount.



FLOW-15938

Flowmaster Header Collector Ball Flange

This header collector kit takes the place of three bolt flange type connections and allows for a leak free and gasket free ball flange type connection.

FLOW-15938	1970-88 All 2.5" to 2.5".....	113.99 kit
FLOW-15925	1970-88 All 2.5" to 3".....	113.99 kit
FLOW-15925	1970-88 All 3" to 3".....	113.99 kit

No Volume Discount.