



VHX

Analog / Digital Gauge System

INSTALLATION AND OPERATION MANUAL

Please read this before beginning installation or wiring.

IMPORTANT NOTE! This system has an odometer preset option that is only available for the first 100 miles of operation. See odometer preset section for instructions and setup information.



4510 W. 61st St. N., Sioux Falls SD 57107
Phone: (605) 332-6513 Fax: (605) 339-4106
www.dakotadigital.com
dakotasupport@dakotadigital.com

Thank you for purchasing a VHX system from DAKOTA DIGITAL. VHX is a loose acronym for Vehicle Hybrid Instrument Systems. Representing the latest electronic dashboard technology for the street rodder, car, and truck enthusiast alike, the VHX system combines modern digital electronics with a traditional look to give the driver up-to-date and accurate information on the operation of his or her vehicle. Fully lit needles, backlit faces, and highly visible LCD message centers are a few features that make the VHX lineup stand out from other aftermarket instrumentation. The VHX system boasts excellent daytime visibility and while under computer control, fully backlit and dimmable for nighttime driving. Monitoring solid state sensors with microprocessor technology and driving precision stepper motors, the VHX dashboard gives the driver unparalleled accuracy. User-customizable display feedback and additional features not typically found on any other brand or type of instrumentation are standard in the VHX system. Digital accuracy and solid state reliability will give you, the driver, quality service for miles down the road that includes a limited lifetime warranty on a product engineered and manufactured in the USA!

VHX INSTRUMENT SYSTEM FEATURES

Digital LCD displays

- Each of the six analog gauges can be displayed here as well as additional functions listed below. Features are available on either display (L or R).

Mileage readings

- Million mile odometer
- Two (A/B) re-settable trip mileage (0-9999.9)
- Re-settable service mileage (0-9999 countdown)

Performance readings

- High speed recall. This is reset at power up and can also be manually reset.
- High rpm recall. This is reset at power up and can also be manually reset.
- 0-60 mph (0-100kmh) time.
- ¼ mile time. This is reset at power up and can also be manually reset.
- ¼ mile end speed (trap speed). This is reset when the ¼ mile time restarts.

Hour meter

- Resettable hours (0-999.9)

English/metric conversion

- Alternate speed and temperature can be displayed in LCD display.

Built-in Indicators

- Left/Right Turn signal indicators
- High Beam indicator
- Check Engine indicator
- Brake warning indicator
- 4x4 indicator
- Wait to Start indicator
- Cruise control indicator
- Gear position indicator which displays full gear word with use of Dakota Digital **GSS-2000** (purchased separately)

Special outputs

- Shift output to activate external light
- Selectable 2000ppm or 4000ppm speed output for cruise or ECM

Demonstration mode

- Holding Switch 2 while turning on the key will start the system going through a preset sequence of readings. To exit the demo mode, turn the key off. You may also wire up a separate switch to power the gauges for demo mode without powering the entire vehicle.

Auxiliary gauge readings in LCD message displays with expansion bus interface modules (BIM)

TYPICAL VHX DISPLAY LAYOUTS

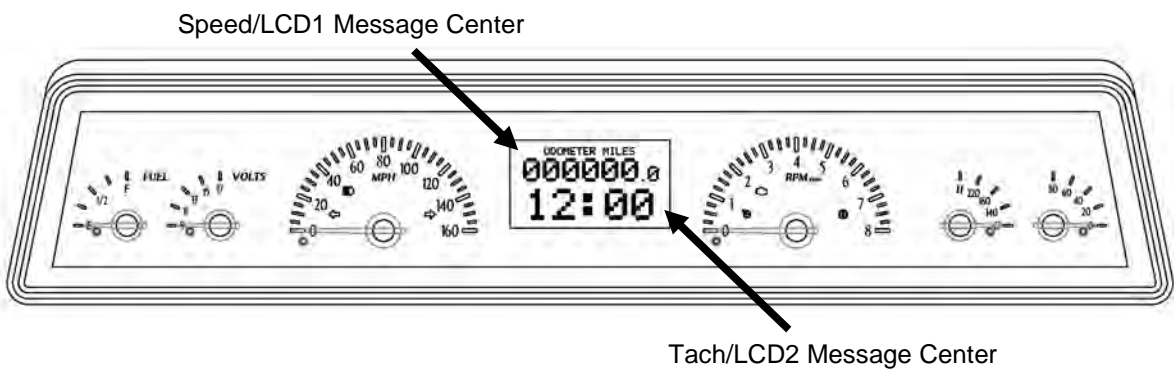
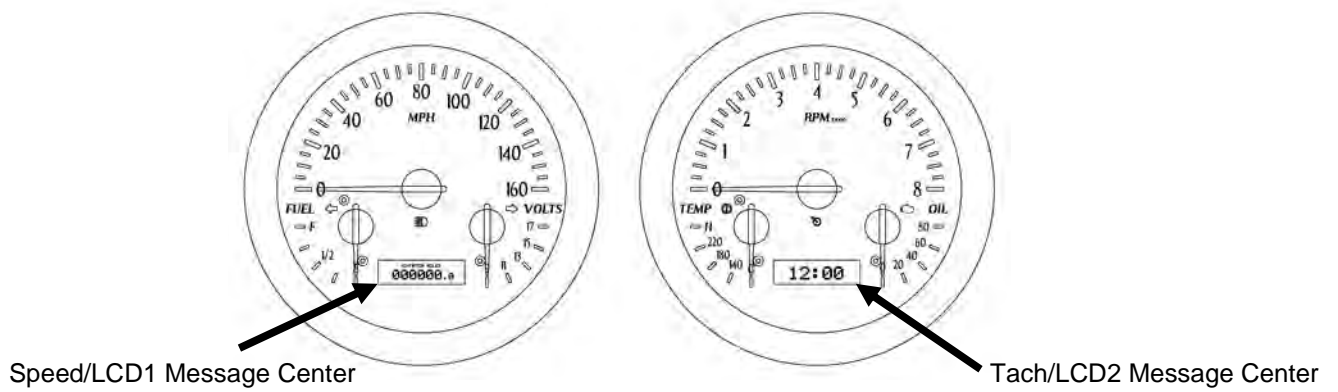
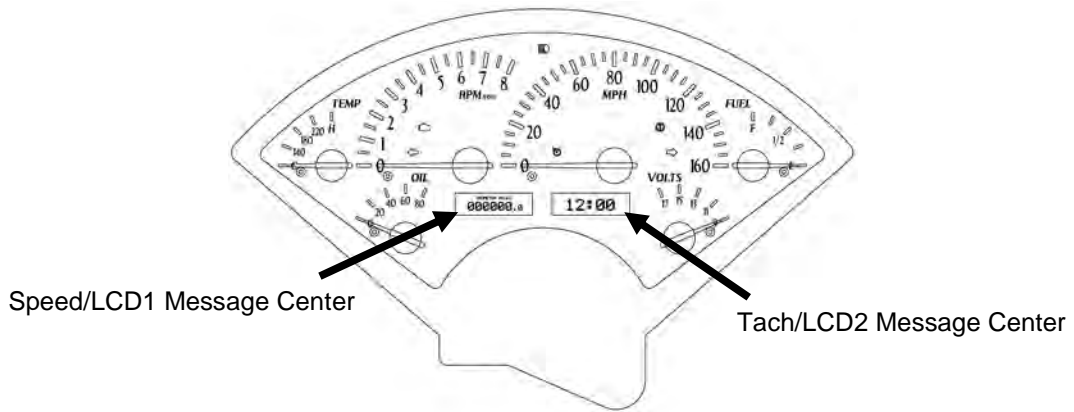

WARNING

These are precision instruments and must be handled with care. Do not disassemble gauges.

CARE AND CLEANING

Never open the system or attempt to remove the needles as the calibration of the instrument system could be thrown off. All systems are calibrated and tested before they leave Dakota Digital.

The clear lens on the front of the VHX system can be cleaned with a mild soap and water solution or common glass cleaners. Use a soft cloth such as a micro-fiber for wiping the lens clean.

MOUNTING SYSTEMS

Most VHX systems and kits will come with a separate instruction sheet with mounting details. Follow this sheet for mounting the actual display system in the dash, and then refer to this manual for wiring and operation instructions.

CONTROL BOX MOUNTING

Once the display panel is in place, mount the control box within reach of the supplied networking cable (approximately three (3) feet). If a longer cable is required, replacement CAT5 cables are available online as well as local electronics stores. Choose a mounting location that will allow you access to wire all of the inputs on either side of the control box. Double sided tape, hook and loop fasteners or screws in the two tabs on the case work fine for securing the control box under the dash.

When selecting a mounting location, avoid placing the control module next to or just opposite of the firewall from ignition components, ie: Ignition coil, HEI, etc. Ignition components can emit tremendous amounts of electrical noise, affecting the operation of electrical components which can cause erratic operation.

******If you are purchasing a longer network cable to connect the display system to the control box please make sure to get a CAT 5, CAT5E, or CAT6 "patch cable" and NOT a "cross over" cable. Replacement cable should be seven feet or less.***

WIRING

While the control box contains several connections, the wiring is straightforward. Depending on how many auxiliary functions you want displayed, not every terminal will be used in most applications. On the pages that follow, we describe the function of each terminal, what they do, and how to wire them.

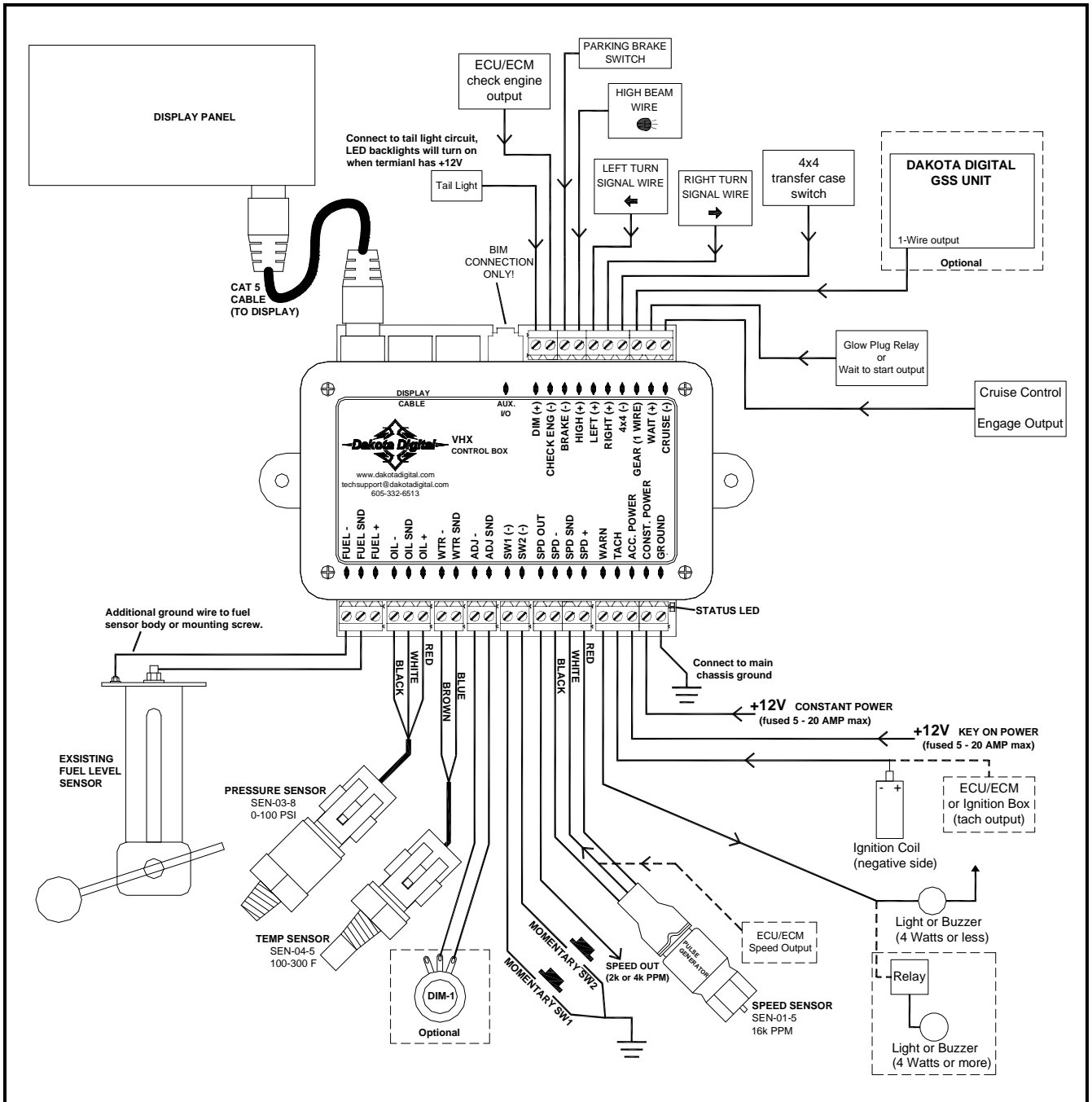

TERMINAL DESCRIPTIONS

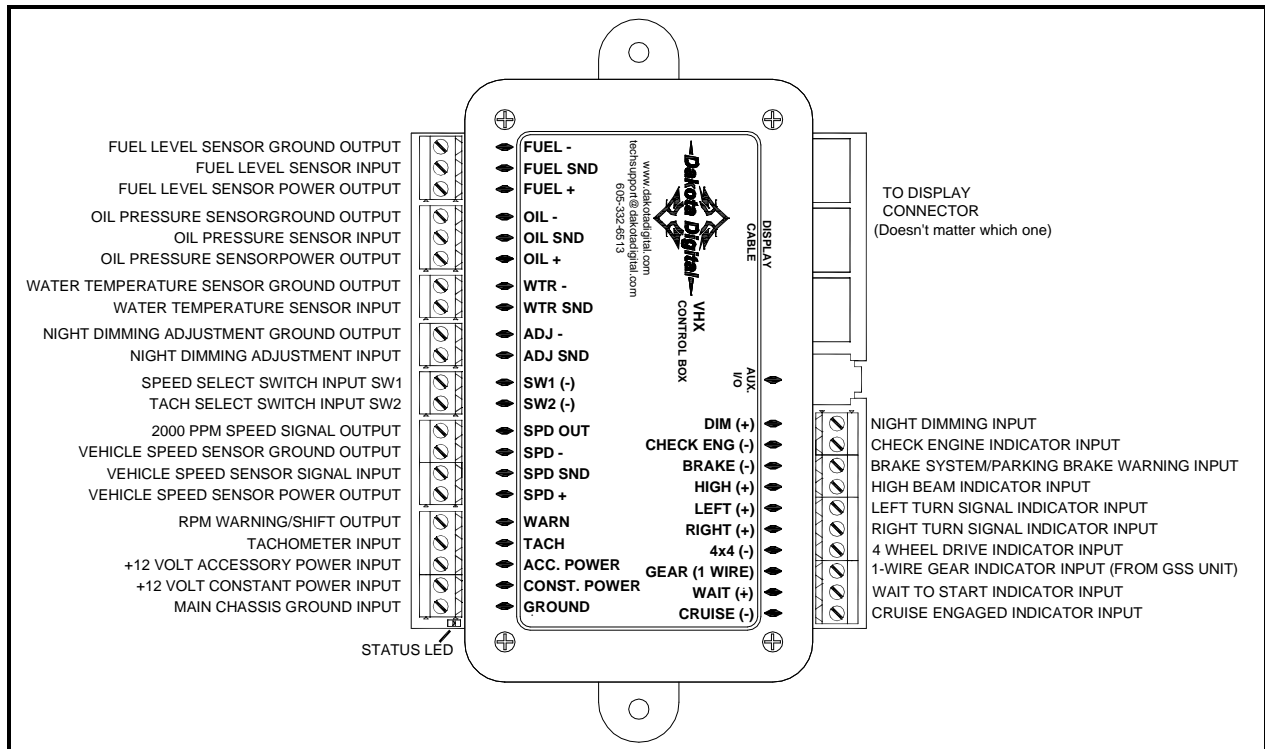

STATUS LED

This LED is located at the corner of the control box, next to the GROUND terminal. The LED is used for diagnostics and for a quick visual check if power is present.

- A steady flash, on and off, about twice a second indicates the system is powered and operating normally.
- On steady indicates low power, below 9V, at the POWER terminals, or that the system is in DEMO mode.
- A short flash once every four seconds indicates the CONSTANT POWER terminal is powered and the system is in stand-by mode.
- Not flashing or lighting indicates loss of power or ground.

GROUND

This is the main ground for the display system. A wire should be run from this terminal to the vehicle's main chassis ground. Use 18 AWG or larger wire to ensure sufficient grounding.

Proper vehicle grounding is extremely important for any gauges (or electronics) to operate correctly. The engine block should have heavy ground cables to the battery, frame, firewall, and body. **Failure to properly ground the engine block or the control box can cause incorrect or erratic operation.**

CONST. POWER

Connect the CONST. POWER terminal to a +12V power from the fuse panel that is "hot" all of the time, or a fused wire (5-20 amp) direct to battery power. This terminal should have power all of the time. The constant +12V supply source should be a fused 5 - 20 amp circuit, the system draws less than 1 amp, so sharing an existing constant power circuit will generally be fine. Use 18 AWG wire to ensure the system receives a sufficient power feed. This terminal keeps the clock memory as well as returning the needles to zero when the system is shut off.

ACC. POWER

Connect the ACC. POWER terminal to accessory +12V power from the fuse panel or vehicle wiring harness. This terminal should have power when the key is on or in the 'accessory' position. In addition to turning on the display system, this is also where the voltmeter gauge senses the vehicle electrical system voltage. The accessory +12V supply source should be a fused 5 - 20 amp circuit, the system draws less than 1 amp, so sharing an existing accessory circuit will generally be fine. Use 18 AWG wire to ensure the system receives a sufficient power feed.

***** Never connect any power terminal to a battery charger alone. The system needs to have a 12 volt battery connected to it. Battery chargers have an unregulated voltage output that will cause the system to not operate properly and may cause damage to the control box.**

TACH

Connect the TACH terminal to the ignition system. •On vehicles using a separate ignition coil, connect to the negative side of the coil. The negative side of the coil will be the wire that goes to the points or electronic ignition module. •For GM HEI ignition equipped engines, connect to the terminal marked "TACH" or on some systems, a single white wire with a spade terminal on it. •On some aftermarket ignition systems, connect to the TACH output terminal. •On computer controlled ignition systems consult a service manual for the wire color and location. •With a magneto system, connect to the kill wire for the tach signal. **Do not connect the TACH terminal to the secondary, or high voltage, side of the ignition coil.**

To ensure that the ignition system does not interfere with any other dashboard functions, do not run the tachometer wire alongside any other sender or input wires. **DO NOT USE SOLID CORE SPARK PLUG WIRES WITH THIS DASHBOARD SYSTEM.** Solid core ignition wires cause a large amount of electromagnetic and radio frequency interference which can disrupt the system operation.

The tachometer is compatible with almost all gasoline engines. The engine cylinder selection, display update rate, tach signal type, and rpm warning point can be adjusted in the setup menu under "TACH". If a diesel engine is being used, you will need a tach interface such as Dakota Digital's **DSL-1** or **DSL-2**. Be aware of the cylinder setting when using computer outputs or reading the tach signal from an ECU. Some GM LS1 engines require the tach to be set up for a 4 cylinder, low voltage signal when reading from the ECU even though it is a V8 engine.

WARN

The WARN terminal is an output to activate a small light or relay for a red-line or shift indicator. The output is ground-activated when the preset warn RPM limit is exceeded. This output can turn on a 4 Watt or smaller 12V bulb or can activate a relay to turn on a larger bulb or buzzer. To wire a warning light to this output, connect one wire from the bulb to 12 volt accessory power and connect the other wire to the WARN terminal.

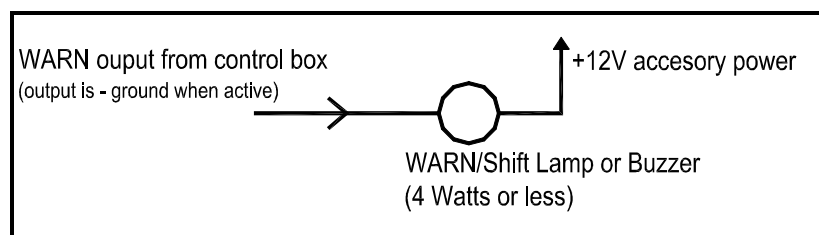

If you need the warn output to be “active high” or provide a +12V voltage to power something larger than 4wattt, a standard 12V relay can be used to accomplish this.

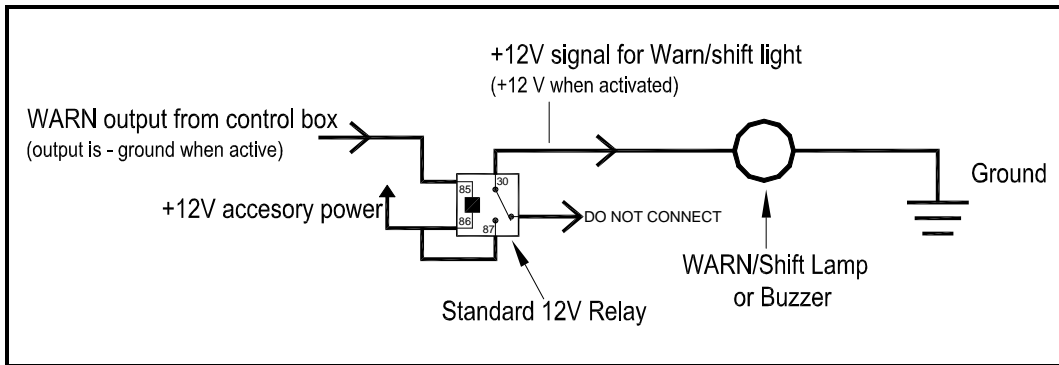

SPD +

This terminal is used to supply power to Dakota Digital speed sensor **SEN-01-5**. This supplies 5V DC to the sensor and should not be hooked up to anything else. Connect the red wire from the **SEN-01-5** to this terminal.

If you are using a 1-wire VSS output from a computer or a two wire pulse generator this terminal should be left open.

*****DO NOT use this terminal to power any other devices; it is a low current +5V output.**

SPD SND

This is where the vehicle speed sensor (VSS) connects. The signal supplied to this terminal will be used by the control box to calculate the speed reading on the display and also for calculating and saving odometer mileage.

Dakota Digital supplies a 3-wire sensor for most of its kits, **SEN-01-5**. If you are using this sensor, the white wire is the speed signal; connect to SPD SND. The red and black wires in the cable are power and ground (5V DC) and their connection is discussed in SPD + and SPD -.

For two wire speed sensors such as a cable driven pulse generator, the polarity of the wires does not matter. Connect one wire to the SPD - (Ground) and the other to the SPD SND terminal. The speed sensor ground wire should be brought back to the control box to ensure a proper signal is received. Twisting the ground and signal wires around each other provides an additional level of interference protection. The speed signal wire should not be routed alongside tach, ignition, or other high current or high voltage wires.

For vehicles which have a vehicle speed signal from a transmission sensor or ECM, tap into the VSS wire and connect it to the SPD SND. Consult a vehicle service manual or wiring diagram to determine wire color and location.

This system can accept 4,000 ppm – 128,000 ppm speed signals with room for adjustment. The speedometer is fully adjustable and calibration is discussed in a later section.

*****Failure to calibrate the speedometer may cause your odometer mileage to increase very rapidly if the speedometer is reading too fast.**

***** The speed signal wire should NOT be routed alongside ignition or other high current/voltage wires.**

SPD -

This terminal is used for speed sensor ground. This insures a proper ground as well as providing proper hook-up for a twisted pair of wires, or a solid state sensor. Only ground the speed sensor here. If you are using a single wire output from a computer for the VSS then this terminal should be left open.

SPD OUT

This terminal can be used to supply a speed signal to auxiliary devices such as a cruise control or radio volume adjustment. The output is scaled to the input speed signal coming into the SPD SND terminal. It can be set to 2,000 PPM or 4,000 PPM.

******If you are using the bus speed signal option, with the output from a BIM module, this output will NOT work.***

SW2 (-) or Tach switch

The SW2 terminal is used for selecting the various RPM, engine, and performance displays and also for entering the demonstration mode. The SW2 input is activated by a ground connection. The push button switch supplied (or any normally open, momentary switch) is wired by connecting one terminal to SW2 and the other terminal to a ground. When the button is pressed and released, the tach/LCD2 message display will change. When the button is pressed and held for a few seconds, any re-settable information displayed will be zeroed.

To enter DEMO mode, press and hold SW2 while turning the key on. The system will light up and say DAKOTA DIGITAL on the message readouts; release the switch and the system will stay in demo mode until the power is cycled off and back on without the switch held. All back lights will be on in demo mode and the needles will sweep back and forth on the gauges.

SW1 (-) or Speed switch

The SW1 terminal is used for selecting the various speed, distance, and warning displays and also for entering the setup menu. The SW1 input is activated by a ground connection. The push button switch supplied (or any momentary normally open switch) is wired by connecting one terminal to SW1 and the other terminal to a ground. When the button is pressed and released, the speed/LCD1 message display will change. When the button is pressed and held for a few seconds, any re-settable information displayed will be zeroed.

ADJ SND

The ADJ SND terminal is an optionally used input that allows you to have control over the dimming brightness. By default, the system will turn on the back lights when the DIM terminal has power, +12V, but this level is adjustable in the LIGHTING setup menu. Using the ADJ SND terminal allows you to have a dash mounted control to vary the brightness while the headlights are on. This requires Dakota Digital's **DIM-1** kit; a stock headlight rheostat will not work.

The DIM-1 has two wires, one connects to the ADJ SND terminal and the other connects to ADJ - ground. The dash mounted dimmer will only vary the display brightness when the DIM terminal has power, +12V.

ADJ -

This terminal provides a ground reference for the optionally installed **DIM-1** for dash mounted dimming control. One wire from the potentiometer will connect to the ADJ - terminal, the other connects to the ADJ SND.

****This terminal should not be used for grounding other sensors or devices or damage to the control box will occur. If not using a Dakota Digital DIM-1, this terminal should be left open.***

WTR SND

The water temperature sender included with this system must be used. Other senders will cause incorrect readings or damage to the control box.

The supplied sensor, Dakota Digital **SEN-04-5**, is a 100-300°F(40-150°C) temp sensor. The sender mounts on the engine block or into the intake manifold so that the end of the sensor is in the engine coolant flow. It has 1/8" NPT threads, adaptor bushings may be used to adapt it for various applications.

The water temp sensor has two wires coming from the harness. One wire will connect to the WTR SND terminal; the other wire will connect to the WTR – terminal. It does not matter which wire goes into either location.

Due to the construction of the sensor, readings at lower temperatures below 100 °F will be inaccurate. The sensor is designed to be accurate from approximately 100 °F - 300 °F.

WTR –

This is the ground reference used for two-wire water temp sensors. This will connect to one of the wires from the Dakota Digital **SEN-04-5**. The other wire will connect to the WTR SND terminal, and it doesn't matter which wire goes into either location.

OIL +

This terminal is used to supply power to Dakota Digital pressure sensor **SEN-03-8**. This supplies 5V DC to the sensor and should not be connected to anything else. Connect the red wire from the **SEN-03-8** to this terminal.

*****DO NOT use this terminal to power any other devices; it is a low current +5V output.**

OIL SND

The oil pressure sender included with this system must be used. Other senders will cause incorrect readings or damage to the control box.

The supplied sensor, Dakota Digital **SEN-03-8**, is a 0-100 psi solid state pressure sensor. The sender can mount on the engine block or in an oil pressure line off of the block. The sender has 1/8" NPT threads. Adaptor bushings may be used to adapt it for various applications.

The oil pressure sensor has three wires coming from the harness, plus one bare shield wire. The WHITE wire will connect to the OIL SND terminal, the RED to OIL + (5V DC), and the black and bare shield wire to OIL –. Do not route the oil sender wire alongside a spark plug wire or other high current or high voltage wires. Doing so can cause incorrect or erratic gauge readings.

If the oil pressure drops below an adjustable warning point, the reading will flash as a low oil pressure warning. The default warning point is 10 psi. If the oil display shows in a LCD message screen as " - - ", this indicates that the control box is sensing a short to ground or out-of-range error from the sender or sender wire. If the oil display shows "EEE" this indicates that the control box is sensing an open circuit or out-of-range error from the sender. If either indication remains on the display, inspect the sender wire for damage, check the routing of the sender wire, check the sending unit grounding, and check that the correct sending unit is connected.

OIL –

This is the ground reference used for three-wire pressure sensor. This will connect to the black wire as well as the bare silver shield wire from the Dakota Digital **SEN-03-8**.

*****The bare wire is the shield wire; connect this wire to the OIL – along with the black wire**

*****DO NOT connect this terminal to any other devices**

FUEL +

This output is not typically used. It is a low current +12V supply for powering solid state fuel sensors. Currently, it does not have an application for any Dakota Digital fuel level sensors.

*****This terminal should not be used with a typical resistive type fuel sensor. For most applications, leave this terminal open. Do not try to power other devices from this terminal or damage to the control box will occur.**

FUEL SND

The fuel gauge sending unit is not normally supplied because the display system can use the existing fuel sending unit that is already in the tank in many cases. The sending units that are compatible with this system are as follows: GM, Ford, VDO, and Stewart Warner. It is also possible to program a custom setting for senders that are not pre-programmed into the system.

Dakota Digital recommends that you run two wires back to the fuel level sensor to insure proper grounds. Use the FUEL - and FUEL SND terminals and run a twisted pair of wires back to your fuel level sensor. Connect the FUEL - terminal to the fuel level sensor body or a mounting screw to insure the sensor is sufficiently grounded. The other wire is the sensor signal which goes to the FUEL SND terminal.

If your wiring harness already has a single wire routed through the vehicle for the fuel sender then it may be used. If using a wire from an existing harness, make sure that the wire does not have power. The fuel sender gets power from the control box only. Fuel senders reference their ground from the sender mounting plate. Make sure that a ground wire is connected from one of the sender mounting bolts to the vehicle frame.

The fuel sender type is selected using the fuel setup menu under "SENDER". The settings are discussed later in the setup section. Anytime the fuel level is below 10%, the reading will flash as a warning of low fuel.

The fuel gauge will initially display "E" until the fuel sender type has been set, and a message will be displayed that says to "SET FUEL SENDER". If the message display shows " --- %FUEL" this indicates that the control box is sensing a short to ground or out-of-range error from the sender or sender wire. If the message display shows "EEE %FUEL" this indicates that the control box is sensing an open circuit or out-of-range error from the sender. If either indication remains on the display, inspect the sender wire for damage, check the routing of the sender wire, check the sending unit grounding, and check that the sender selection is set correctly for the sending unit that is connected.

FUEL -

This terminal is used to provide a ground connection for the fuel level sensor. Dakota Digital recommends that you use the FUEL - terminal and run a twisted pair of wires back to your fuel level sensor. Connect the FUEL - terminal to the fuel level sensor body or a mounting screw to insure the sensor is sufficiently grounded. One terminal on the sensor is the signal which goes to the FUEL SND terminal.

*****For fuel level sensors that are attached to an electric fuel pump, or if you have an electric fuel pump in the tank, make sure that the fuel pump is externally grounded to the vehicle chassis. Attempting to ground the fuel pump to the Dakota Digital control box will result in erratic operation and damage to the control box.**

CRUISE (-)

The CRUISE terminal can be used as a "cruise engaged" indicator. The CRUISE input is activated by a ground signal from a compatible cruise control harness. Whenever the CRUISE input is grounded, the system will display a small green "cruise engage" indicator.

WAIT (+)

The WAIT terminal can be used as a “wait to start” or glow plug indicator. The WAIT input is activated by a 12 volt signal from the glow plugs. Whenever the WAIT input is powered, +12V, the system will display “WAIT” on the LCD1 message display. This message can be cleared by pressing and holding switch 1, or once the WAIT terminal loses the +12V signal.

GEAR (1 wire)

The GEAR terminal is used for the gear shift indicator. The indicator is built into every system, but will not light up unless a Dakota Digital **GSS-1000/2000/5000** gear shift sending unit is connected, telling the system what gear the transmission is in. The gear shift sending unit is not included with the system and must be purchased separately if desired.

The GEAR terminal will connect to the FIRST terminal on a **GSS-1000** or to the 1-WIRE terminal on a **GSS-2000** or **GSS-5000**. Follow the instructions in the GSS manual for use with a single wire display system. When the gear shift sending unit is connected, the gear name will be shown on the LCD1 message display.

NOTE: The system will automatically change to the gear display for a few seconds whenever the gear position changes, even if viewing a different message display.

4x4 (-)

The 4x4 terminal can be used on four wheel drive vehicles. The 4x4 input is activated by a ground signal from a switch on the transfer case. Connect a wire from this terminal to the switch on the transfer case. Whenever the 4x4 input is grounded the system will display “4X4 ON” on the LCD1 message display. When the signal turns off, the system will briefly display “4X4 OFF” on the message display.

RIGHT (+)

The RIGHT terminal is activated by a 12 volt signal from the turn signal flasher. When this terminal has 12 volts, a green arrow will light up on the display face. An existing wire from the vehicle for the right turn indicator can be used or a new wire can be connected from the turn signal flasher or power wire feeding the right turn signal bulb.

LEFT (+)

The LEFT terminal is activated by a 12 volt signal from the turn signal flasher. When this terminal has 12 volts, a green arrow will light up on the display face. An existing wire from the vehicle for the left turn indicator can be used or a new wire can be connected from the turn signal flasher or power wire feeding the left turn signal bulb.

HIGH (+)

The HIGH terminal is activated by a 12 volt signal from the headlight high beam wire. When the terminal has 12 volts, a blue high beam indicator will light up on the display face. An existing wire from the vehicle for the high beam indicator can be used or a new wire can be connected from the high beam side of the hi/low beam switch.

BRAKE (-)

The BRAKE terminal can be used as a brake system warning indicator. The BRAKE input is activated by a ground signal from the brake pressure switch on the master cylinder or from the parking brake set switch. Connect a wire from this terminal to the pressure switch on the master cylinder or consult a vehicle service manual to determine color and location of an existing wire. Whenever the BRAKE input is grounded, the system will display “CHECK BRAKE” on the LCD 1 message display. This message can be cleared by pressing and holding SW1. There is also a red exclamation indicator that will illuminate on the display face when the terminal is grounded.

CHECK ENG (-)

The check engine terminal is used with fuel injection ECM's to display engine problems and trouble codes. The CHECK input is activated by a ground signal from the ECM. Whenever the check input is grounded, the system will display "CHECK ENGINE" on the LCD1 message display. This message can be cleared by pressing and holding SW1. There is also a red check engine indicator that will illuminate on the display face.

For certain ECM's, when placed into diagnostic mode, trouble codes can be read by counting the flashes of the check engine indicator. Consult a service manual for the fuel injection system that you have for further information on trouble codes or if that is how your system operates. With some ECM's, a 12 volt light bulb may need to be connected in addition to the CHECK input in order to provide proper current loading. In this case, both the bulb and our display system indicator would come on when the check engine wire is "active".

DIM

The backlights and needles in the VHX systems are designed to illuminate when the headlights are turned on. Connect the DIM terminal to the taillight or parking light circuit so it has 12 volts whenever the headlights are on. When power is applied to the DIM terminal, the instruments will illuminate at a preset brightness level. When the DIM terminal does not have power, the backlighting will be off, unless its enable in setup to be on in day time operation.

The night brightness level is adjustable two different ways. This preset brightness is adjusted in the setup menu "LIGHTING". See ADJ SND for a description of the second method.

AUX. I/O

This jack is used to connect future bus expansion modules (BIM). Do not attempt to plug in any other device to this jack or damage to the control box will occur. This connector should be left open, unless using a Dakota Digital product designed for it. Operation is discussed with BIM units purchased separately from Dakota Digital.

DISPLAY CABLE CONNECTION

This is where the network/CAT 5 cable from the display system plugs into the control box. All three connectors are exactly the same output so it does not matter which one you choose to use. Some systems may have two cables leading down from the system and you will need to connect both cables, and it doesn't matter which one. Unused jacks can be left open.

Some systems may also need a cable connecting the two halves or multiple gauges in the system together. If the back of the displays have more than one connector you will need to jumper it to the other display that has only one. The shorter cable supplied in the kit is for this connection.

*****If you are purchasing a longer network cable to connect the display system to the control box please make sure to get a CAT 5, CAT5E, or CAT6 "patch cable" and NOT a "cross over" cable.**

SETTING UP THE CONTROL BOX

Below is the list of setup menus. You must have SW1 wired to enter setup, SW2 will be used in some menus as well; descriptions of each menu are below. **Pay close attention to Setup menus and options as incorrect settings will cause faulty readings on the displays.**

Main Menu	Sub Menu	Description
SPEED	SENDER (NORMAL, BUS)	Select sensor type
	AUTO	Auto calibrate speed
	ADJUST	Adjust the speed calibration
	SERVICE (OFF, 500 - 7500)	Select the service countdown
	OUTPUT (2K PPM, 4K PPM)	Select output speed signal PPM setting
	DONE	Exit setup menu
TACH	ENGINE (BUS, 1 - 16)	Set engine cylinder count
	UPDATE (SLOW, MID, FAST)	Set rpm update rate
	WARN (2200 - 14800)	Set rpm shift warning point
	SIGNAL (5V LOW, 12V HIGH)	Select rpm signal voltage level
	DONE	Exit setup menu
VOLT	WARNING (LOW 10.0 - 13.1)	Set low volt warning point
	DONE	Exit setup menu
WATER	SENDER (DD F, DD C, BUS F, BUS C)	Select sensor type
	WARNING (150-300F / 65 -148C)	Set high temp warning point
	TEST	Display sensor ohm reading
	DONE	Exit setup menu
OIL	WARN (LOW 5 - 36)	Set low pressure warning point
	TEST	Display sensor voltage reading
	DONE	Exit setup menu
FUEL	SENDER (SW 33, CUSTOM, GM 30, GM 90, GM 250, F 10, F 150, V 180)	Select sensor type
	CUSTOM	Calibrate custom fuel sensor
	TEST	Display sensor ohm reading
	DONE	Exit setup menu
LIGHTING	DIM LEVEL (ADJUST 0-31)	Change preset night dimming
	DAY LEVEL (ADJUST 0-32)	Change day time backlighting
	DONE	Exit setup menu
BIM	SCAN	Check/scan for connected modules
	SETUP	Enter setup (only when modules present)
	DONE	Exit setup menu
DISPLAYS	INDICATORS (LIGHT ONLY, LIGHT+LCD)	Enable indicators on face and LCD
	LOCATION (1, 2, 1+2, OFF)	Select display location
	DONE	Exit setup menu

INFO

VERSION
SPEED CAL
DONE

Current software code
Current pulse per mile cal value saved
Exit setup menu

SET ODOM

Used to preset odometer miles

To enter the setup mode, press and hold SW1 while turning the key/ACC power on. The display should light up and show **SETUP** on the speedometer/LCD1 and tachometer/LCD2 message displays. Release the switch and **SETUP SPEED** should display on LCD1, this is the start of the setup menus. Press and release switch 1 (SW1) to advance through the main menus. A press and hold will enter the sub menu. A press and hold is also used to save the setting and jump to the next option, or exit a menu when **DONE** is displayed.

You can exit setup at any time by switching off the keyed power.

SPEEDOMETER SETUP/CALIBRATION

There are two main methods for calibrating the speedometer, auto cal and adjust. Auto cal requires that you have one measured mile marked out. Adjust requires you to follow another vehicle going at a set speed, use a handheld GPS with speedometer function, or time yourself over a mile to determine your speed.

*** Dakota Digital recommends you start with the Auto Cal method to get the speedometer close. If you find it's reading too fast/slow after the Auto Cal, then attempt the Adjust mode.**

Press and hold SW1, then turn the key on and start the engine. Once the engine is running, release SW1. **"SET SPEED"** should be displayed. Press and hold the switch until **"SPEED SENDER"** is displayed to go into the speed setup menus, release SW1.

Now you can press and release the switch to scroll through the sub-menus, **"SENDER"** **"AUTO"** **"ADJUST"** **"SERVICE"** **"OUTPUT"** **"DONE"**. When you get to the desired sub-menu, press and hold the switch to select it.

Speed sensor setup (SENDER)

This menu is used to set the speed sensor input type. You can use the supplied pulse generator or existing speed sensor for most applications. You can also read the speed signal with the use of a bus interface module (BIM). Dakota Digital offers a BIM that will allow you to read the speed signal from an ECU if you are installing the system in a vehicle equipped with the OBDII port or a drivetrain from a newer vehicle; most 1996 and newer vehicles have this.

If you are using a Dakota Digital pulse generator or feeding an ECU signal into the SPD SND terminal, this is considered a NORMAL signal.

When **"SPEED SENDER"** is displayed, press and hold SW1 until the message screen changes.

Release SW1 and the current sender selection will be displayed

Press and release SW1 to toggle between **"NORMAL"** and **"BUS"**

When the desired setting is displayed press and hold SW1 until **"DONE"** is displayed

Release the switch to go onto the next sub menu item.

Auto Cal (AUTO)

This menu is used to calibrate the speed signal by driving a measured mile. Start this procedure with the vehicle stopped at the beginning of a known measured mile. Shut the car off, press and hold SW1 and turn the key on and start the car then release the switch to get into setup once the car is running. Then select the speed setup menus.

When "SPEED AUTO" is displayed press and hold SW1 until you get "SPD PULSES 0"
Release SW1 and the speed/LCD1 message display should read "SPD PULSES 0", LCD2 will read "SETUP". The other gauges should display the current readings (tach, fuel, volt, water, and oil). Stopped at the beginning of the measured mile, the "SPD PULSES 0" reading should stay at "0" until you start driving. If this number is increasing while stopped, you have something wired wrong or are picking up interference please check connections and wire routing before continuing or you will have incorrect readings later.

Begin driving the measured mile.

The "SPD PULSES X" reading should start to increase as you travel, indicating the pulses received from the speed sensor or VSS. This is known as the pulses per mile (PPM).

The acceptable range for this is about 2,000 – 250,000.

Once you reach the end of the marked mile, or are passing the marker, press and release SW1. The readings will zero out, then everything should move up to the correct values and the speedometer should now be displaying your current speed.

Auto Cal is now complete and your speedometer should be reading correctly.

NOTES: You do not have to drive at a constant speed nor do you have to avoid stopping during Auto Cal. When completed, you do not need to stop, you may, but you can also just press and release SW1 as you pass the 1 mile mark.

The message display cannot be used to determine when the mile has been driven, it's only there as a reference to indicate pulses are coming into the control box. Even if you have an 8,000 PPM sensor you may calibrate at 9xxx PPM (for example) due to gearing and tire size.

Also be aware that the odometer miles are calculated from the speedometer cal value; if it is not calibrated properly, the odometer miles could be higher/lower than actual.

******If you do not receive more than 2,000 pulses during calibration the unit will error out and display a brief "PULSE TO LOW" message and revert to a default PPM setting.***

Adjust Mode (ADJUST)

Adjust is slightly different depending on what your input signal is selected to in the SENDER menu.

When "ADJUST" is displayed, press and hold SW1 until the message screen changes. Release SW1.

If "NORMAL" is selected for the sender type, it will allow you to adjust the signal that is being supplied to the SPD SND terminal coming from a pulse generator or ECU. The fuel, volt, oil, water, and tach will operate normally. The speedometer will show the speed reading and the speed/LCD1 message display will say "XX ADJ MPH". Begin driving at a known speed. Press and hold SW1 to increase the speedometer reading, the next press and hold of SW1 will decrease the speedometer reading. You can continue adjusting up and down as needed until the reading is correct. When the speedometer is correct, stop and restart the system, by turning the key/power off and then starting the vehicle back up. The new calibration will be saved when there is no switch press for eight seconds.

If "BUS" is selected for the sender type, the speed signal should be coming into the AUX I/O port through the use of a future BIM module. The adjustment ratio ranges from 75 – 125% on this setting as it is assumed that the signal from the external device is the correct pulse rate, there are only provisions for slight adjustment. The LCD1 message will light up and show "ADJUST SPD XXX%", XXX is adjustable from 75 – 125 and is the percentage the input is corrected by. If set to 100 the signal is uncorrected and whatever the BIM module is reading is displayed on the dash.

NOTES: For adjust mode you can follow another vehicle, time yourself, or use a GPS as a reference. A chassis dyno is another excellent way to use the Adjust mode. Also be aware that the odometer miles are calculated from the speedometer cal value, if calibrated properly, odometer miles could be higher/lower.

Service countdown meter (SERVICE)

The service countdown meter allows you to set a mileage value that will decrease as the odometer miles increase. When the value gets to zero, a message "SERVICE DUE" will appear on the LCD1 message display on power up to remind you that service is due. This can be used for routine maintenance reminders such as oil changes.

When "SERVICE" is displayed press and hold SW1 until the message screen changes.

Release the switch and the current service setting will be displayed.

Press and release SW1 to increase the value from "OFF" then "500"-"7500" in 500 mile increments.

Once the desired setting is displayed, press and hold SW1 until "DONE" is displayed to save the value.

Speed Output (OUTPUT)

If a speed signal is needed for an ECM or cruise control, the SPD OUT terminal can be used. This terminal can supply a 2,000 ppm or 4,000 ppm signal.

When "OUTPUT" is displayed press and hold SW1 until the message screen changes.

Release the switch. The current PPM output will be displayed.

Press and release SW1 to toggle from "2K PPM" or "4K PPM".

When the desired setting is displayed, press and hold SW1 until "DONE" is displayed

Release the switch to go on to the next menu item.

Exit setup (DONE)

This will allow you to exit the speed setup and go on to the next setup menu.

When "SPEED DONE" is displayed, press and hold SW1 until you get "DONE"

Release the switch to go on to the next menu

TACHOMETER SETUP

The control box can be set to read from 1-16 cylinder ignition signals. It can also be set to read either 12 volt tach signals or 5 volt tach signals found on some engine computers. The digital tachometer update rate can be adjusted between slow, mid, and fast. The RPM warning/shift point can be adjusted from 2,200 – 14,800. The digital tachometer will read from 300 – 17,500 rpm, at RPM's above 9,990 the reading will be displayed as RPMx10 in the message center (12,000=1,200).

You can also read the tach signal with the use of a future bus interface module (BIM). Dakota Digital offers a BIM that will allow you to read the speed signal from an ECU if you are installing the system in a vehicle equipped with the OBDII port or a drivetrain from a newer vehicle, most 1996 and newer vehicles have this.

Press and hold SW1 while turning the key on. Release the switch. Press and release SW1 to get to the "TACH" setup menu. Press and hold the switch until "TACH ENGINE" is displayed to enter the tach setup menus, then release SW1.

Now you can press and release the switch to scroll through the tach sub-menus, "ENGINE" "UPDATE" "WARN" "SIGNAL" "DONE". When you get to the desired sub-menu, press and hold the switch to select it.

Engine cylinder setup (ENGINE)

This menu is used to set the current number of cylinder that the tach signal is providing. It is adjustable from 1 -16 cylinders.

When "SETUP ENGINE" is displayed, press and hold SW1 until the message screen changes.

Release SW1 and the current cylinder setting will be displayed.

Press and release SW1 to increase the value from "1" – "16" or "BUS"

When the desired setting is displayed, press and hold SW1 until "DONE" is displayed

Release the switch to go onto the next sub-menu item.

***NOTE: When selecting the cylinder count, be aware of tach signals coming from ECMs, oftentimes a V-8 engine computer may actually output a 4 cylinder tach signal. This would require the ENGINE selection to be set for "4" not "8" as you might expect.**

Display update setup (UPDATE)

The display update rate can be adjusted so the reading on the tachometer doesn't change so quickly. This is a personal preference and is just used to "slow" the reading by averaging. The value can be changed from slow, mid, or fast.

When "UPDATE" is displayed, press and hold SW1 to enter the "UPDATE" setup menu.

Release SW1 and the current update rate will be displayed.

Press and release SW1 to increase the value from "SLOW" "MID" or "FAST"

When the desired setting is displayed press and hold SW1 until "DONE" is displayed

Release the switch to go on to the next sub-menu item.

Rpm warning setup (WARN)

This is used for the turn on point for the WARN output on the control box. When the rpm reading is above this setting, the output will activate, providing a ground signal. It can be used to turn on a shift light or other rpm based devices. The value is adjustable from 2,200 RPM – 14,800 RPM in 100 RPM increments.

When "WARN" is displayed, press and hold SW1 to enter the "WARN" setup menu

Release SW1 and the current warning point will be displayed

Press and release SW1 to increase the value from "2200" – "14800"

When the desired setting is displayed press and hold SW1 until "DONE" is displayed

Release the switch to go onto the next sub-menu item.

Tach signal setup (SIGNAL)

This menu will allow you to select from two different tach-input types. A low voltage, "5V LO", tach signal or a high voltage tach signal, "12V HIGH". A low voltage signal is usually one that would be picked up from the ECM. Low voltage may also be considered a 0-5V square wave. If you are getting the tach signal from the ignition coil or points, set this for the high voltage signal "12V HIGH". To pick up a tach signal from a traditional ignition coil, connect a signal wire to the negative side of the coil.

When "SIGNAL" is displayed, press and hold SW1 to enter the "SIGNAL" setup menu
Release SW1 and the current setting will be displayed
Press and release SW1 to toggle from "12V HIGH" to "5V LOW"
When the desired setting is displayed, press and hold SW1 until "DONE" is displayed
Release the switch to go on to the next sub-menu item.

Exit tach setup (DONE)

This will allow you to exit the tach setup and go on to the next setup menu.

When "TACH DONE" is displayed, press and hold SW1 until "DONE" is displayed
Release the switch to go on to the next menu.

VOLT SETUP

The volt setup allows you set a warning point that will cause the volt display to flash whenever the voltage drops below the warning value. The low voltage point can be set from 10 - 13.1 volts. There is only one thing to set in the volt sub-menu; either "WARNING" or "DONE" will be displayed.

Press and hold SW 1 while turning the key on. Release the switch. Press and release SW1 to get to the "VOLT" setup menu. Press and hold the switch until "VOLT WARNING" is displayed to enter the volt setup menus, then release SW1.

When "WARNING" is displayed, press and hold SW1 until you see "VOLT WARN LOW" followed by a number. Release SW1; this is the current voltage warning point.

Press and release SW1 to increase the value from "10.0" – "13.1"

When the desired setting is displayed press and hold SW1 until "DONE" is displayed

Release the switch to go onto "VOLT DONE" Press and hold SW1 to exit "VOLT" setup menu.

WATER TEMP SETUP

The water temp setup allows you select the units the temperature is displayed in, Fahrenheit or Celsius. It also allows you to set a high temperature warning point that will cause the message to display in LCD1 whenever the reading on the display is higher than the set point. There is also a test mode that will display the resistance for the sensor for trouble shooting assistance.

Press and hold SW1 while turning the key on. Release the switch. Press and release SW1 to get to the "WATER" setup menu. Press and hold the switch until "WATER SENDER" is displayed to enter the water setup menus, then release SW1.

Now you can press and release the switch to scroll through the water sub-menus, "SENDER" "WARNING" "TEST" "DONE". When you get to the desired sub-menu press and hold the switch to select it.

Temp sensor setup (SENDER)

This menu is used to set the temp sensor type. Dakota Digital only offers one temp sensor for this system, it is **SEN-04-5**, 100-300 F(40-150 C), 1/8" NPT threads. You can use bushings to adapt the sensor to various locations. You will select "DD F" to read in Fahrenheit, or select "DD C" to read in Celsius.

You can also read the temp with the use of a future bus interface module (BIM). Dakota Digital offers a BIM that will allow you to read the engine temp signal from an ECU if you are installing the system in a vehicle equipped with the OBDII port or a drivetrain from a newer vehicle, most 1996 and newer vehicles have this. You will select "BUS F" to read in Fahrenheit, or select "BUS C" to read in Celsius.

***NOTE: Selecting Celsius units will only change the reading on the LCD message centers since the VHX needle sweeps are set for Imperial units. You will also need to enable the message in order to display it.**

When "SENDER" is displayed, press and hold SW1 until the message changes
Release SW1 and the current sensor selection will be displayed
Press and release SW1 to scroll through the sensor options "DD F" "DD C" "BUS F"
"BUS C"

When the desired setting is displayed, press and hold SW1 until "DONE" is displayed
Release the switch to go on to the next sub- menu item.

Temp warning setup (WARNING)

This menu will allow you to select the high temperature warning point. When the display value is higher than this point, a high temp warning message will flash the current water temp in the LCD1 display. The value is adjustable from 150 – 300 F (65-148 C).

When "WARNING" is displayed, press and hold SW1 until the message changes
Release SW1 and the current warning point will be displayed
Press and release SW1 to increase the value from "HI 150F" – "HI 300F"
When the desired value is displayed, press and hold SW1 until "DONE" is displayed
Release the switch to go on to the next sub-menu item.

Temp sensor test (TEST)

This menu will allow you to check the resistance the control box is reading from the water temp sensor. This can be used for a diagnostic tool if you are having troubles or feel that the reading is incorrect. For the Dakota Digital **SEN-04-5** the resistance decreases as temperature increases. Typical values for the Dakota Digital **SEN-04-5** sensor are:

100F - 500 ohms
200F - 75 ohms
300F - 19 ohms

If the message display is showing "EEE" this is an open connection or no sensor connected. If it is reading " --- " this is indication of a short.

When "WATER TEST" is displayed press and hold SW1 until the message screen changes.
Release SW1 and the current resistance from the fuel level sensor will be displayed as
"TEST TEMP" "XXX OHMS" where xxx is the resistance seen at the control box.
Press and release SW1 to scroll to other sensor inputs if you wish "OIL" "FUEL" "TEMP"
Once complete, hold SW1 until "DONE" is displayed.
Release the switch to go on to the next sub-menu item.

Exit water temp setup (DONE)

This will allow you to exit the water temp setup and go on to the next setup menu.

When "WATER DONE" is displayed, press and hold SW1 until you get "DONE"
Release the switch to go onto the next menu.

OIL PRESSURE SETUP

Dakota Digital only offers one pressure sensor for this system, **SEN-03-8**, 0-100 psi solid state sensor with 1/8" NPT threads. The oil pressure setup allows you set up a low pressure warning point that will cause the message display to flash the oil pressure reading whenever the value is lower than the warning set point. There is also a test mode that will display the voltage from the sensor for trouble shooting assistance.

Press and hold SW 1 while turning the key on. Release the switch. Press and release SW1 to get to the "SETUP OIL" menu. Press and hold the switch until "OIL WARN" is displayed to enter the oil pressure setup menus, then release SW1.

Now you can press and release the SW1 to scroll through the oil sub-menus, "WARN" "TEST" "DONE". When you get to the desired sub-menu, press and hold the switch to select it.

Oil pressure warning setup (WARN)

This menu will allow you to select the low pressure warning point. When the display value is lower than this point, the oil pressure will display and flash in the LCD1 message center. The value is adjustable from 5 – 36 psi.

When "OIL WARN" is displayed, press and hold SW1 until the message screen changes. Release SW1, and the current warning point will be displayed as "OIL WARN LOW xx" where "xx" is the current warning point.

Press and release SW1 to change the value from "LOW 05" – "LOW 36"

When the desired value is displayed press and hold SW1 until "DONE" is displayed. Release the switch to go on to the next menu item.

Oil pressure sensor test (TEST)

This menu will allow you to check the voltage the control box is reading from the pressure sensor. This can be used for a diagnostic tool if you are having troubles or feel that the reading is incorrect. For the Dakota Digital **SEN-03-8**, 0-100 psi sensor, the voltage increases with pressure. At 0 psi, the voltage should be close to 0.5V at 100 psi the voltage should be close to 4.5V.

When "OIL TEST" is displayed press and hold SW1 until the message screen changes. Release SW1 and the current voltage from the oil pressure sensor will be displayed as "TEST OIL x.x VOLTS" where x.x is the voltage seen at the control box.

Press and release SW1 to scroll to other sensor inputs if you wish "FUEL" "TEMP" "OIL". Once complete, hold SW1 until "DONE" is displayed. Release the switch to go onto the next sub-menu item.

Exit oil pressure setup (DONE)

This will allow you to exit the oil pressure setup and go on to the next setup menu.

When "OIL DONE" is displayed, press and hold SW1 until you get "DONE". Release the switch to go on to the next menu.

FUEL SETUP

The control box can read seven common fuel level sender resistance values. If your sender is not shown in the table below, the system can be programmed to read a custom sender. The table below shows the seven pre-programmed senders and their respective empty and full resistance values.

Sender type	Menu	Empty R	Full R
GM 0-30 ohm (mid 60's-earlier)	GM 30	0 ohms	30 ohms
GM 0-90 ohm (mid 60's-late 90's)	GM 90	0 ohms	90 ohms
GM 40-250 ohm (late 90's-later)	GM 250	40 ohms	249 ohms
FORD 73-10 ohm (earlier -late 80's)	F 10	73 ohms	10 ohms
FORD 20-150 ohm (late 80's-later)	F 150	20 ohms	150 ohms
VDO 10-180 ohm	V 180	10 ohms	180 ohms
SW/SUN 33-240	SW 33	240 ohms	33 ohms
User programmed	CUSTOM	User settable	User settable

To get into the fuel setup menus, start with the key off.

Press and hold SW1 while turning the key on, then release SW1.

Press and release SW1 to scroll through the setup menus until you get to "SETUP FUEL".

When "SETUP FUEL" is displayed, press and hold SW1 until "FUEL SENDER" is displayed, then release SW1.

This is the start of the fuel setup menus, now make your selection between "SENDER" "CUSTOM" "TEST" or "DONE". When you get to the desired sub-menu, press and hold the switch to select it.

Fuel sensor setup (FUEL SENDER)

This menu is used to select the fuel level sensor type. The table above shows the seven options and resistance ranges as well as the custom option.

When "FUEL SENDER" is displayed, press and hold SW1 until you get "SENDER xx xx" where "xx xx" is the current sensor it is set to.

Release SW1, and the current sensor selection is displayed.

Press and release SW1 to scroll through the sensor options "GM 30" "GM 90" "GM 250" "F 10" "F 150" "V 180" "SW 33" "CUSTOM"

When the desired setting is displayed, press and hold SW1 until "DONE" is displayed.

Release the switch to go onto the next menu item.

Note: You must calibrate the custom sensor curve to your specific fuel sensor. If you are selecting the Custom setting follow the steps below to save your sensors resistance curve.

Custom fuel sender curve setup (CUSTOM)

You will need to have the sender out of the tank, or begin with the tank empty and add fuel during the custom fuel sender setup.

***** The factory default custom curve is 110 empty and 5 ohms full**

*****You must select "CUSTOM" in the Fuel Sender menu after you have calibrated the custom curve so the system knows that you want to use it.**

When "CUSTOM" is displayed press and hold SW1 until the message screen changes.

The message display will show "CUSTOM --%" and "XXX OHMS", release SW1.

The message display will show "CUSTOM 00%" and "XXX OHMS", where xxx is the current resistance the control box is seeing from the fuel sensor. You should be able to move the float up and down at this point and see the resistance values follow the curve of your sensor.

Now, with the float in the empty position, press and release SW1.

The message display will show "CUSTOM 33%" and "XXX OHMS". Move the float to 1/3 full and then press and release SW1.

The message display will show "CUSTOM 66%" and "XXX OHMS". Move the float to 2/3 full and then press and release SW1.

The message display will show "CUSTOM 99%" and "XXX OHMS". Move the float to the full position and then press and release SW1. The new sender is now stored under the "CUSTOM" sender selection.

The message display will be back in the fuel sub-menu showing "FUEL TEST".

******If the resistances recorded during custom calibration are not in sequence you will get a "FAIL" message at the end of calibration. No values will be saved and calibration must be started again. Make sure the resistance of the sensor is linear from empty to full.***

Note: Once the custom sender is programmed, go back and ensure that "CUSTOM" is selected in the "FUEL SENDER" menu. Programming the custom sender curve does not automatically make it the 'active' sender.

Fuel sensor test (TEST)

This menu will allow you to check the resistance the control box is reading from the fuel level sensor. This can be used as a diagnostic tool if you are having troubles or feel that the reading is incorrect. You can use the table of fuel sensors above to get an idea on the resistance you should be seeing.

When "FUEL TEST" is displayed press and hold SW1 until the message screen changes.

Release SW1 and the current resistance from the fuel level sensor will be displayed as

"TEST FUEL" "XXX OHMS" where xxx is the resistance seen at the control box.

Press and release SW1 to scroll to other sensor inputs if you wish "TEMP" "OIL" "FUEL"

Once complete, hold SW1 until "DONE" is displayed.

Release the switch to go onto the next sub-menu item.

Note: Fuel level sensors are generally not precise; in the test function you should expect to see some error. For instance a GM 0-90 sensor may display 5 ohms empty and 97 ohms full. If you are within 10% of the values in the table, this is considered within specification.

Exit fuel setup (DONE)

This will allow you to exit the fuel setup and go on to the next setup menu.

When "FUEL DONE" is displayed, press and hold SW1 until "DONE" is displayed

Release the switch to go on to the next menu.

LIGHTING SETUP

The lighting menu, "LIGHTING", allows you to set the backlight brightness level for the LCD message centers under daytime viewing conditions. You can also adjust the level the backlights will turn on to when the DIM terminal has power applied to it for night time viewing. You can even enable the back lights during the day if you wish so that the tic marks and needles are always lit.

If you are using the separately purchased **DIM-1** kit from Dakota Digital, the dim brightness level doesn't matter; when the DIM terminal has power applied to it, you have total control of the brightness level with the twist of a knob. If the **DIM-1** is wired to the ADJ SND and ADJ – terminals, the dim setting will be overridden by the **DIM-1** knob.

To set the level of brightness for night time driving:

Press and hold SW1 while turning the key on. Release the switch.

Press and release SW1 to get to the "LIGHTING" setup menu.

Press and hold the switch until "LIGHTING DIM LEVEL" is displayed, then release SW1.

Press and hold SW1 to enter brightness adjustment until a screen that says "DIM LEVEL ADJUST --", then release the switch.

A screen that reads "DIM LEVEL ADJUST XX" should be displayed, where xx is the current level.

Press and release SW1 to select desired "night time" brightness for the gauges. The number is adjustable from 0 (off) to 31 (full brightness). Whenever the DIM terminal has 12V applied to it, the back lights will turn on to this level.

Next; press and release SW2 to save setting. Yes you have to use SW2 to save.

To set the level of brightness for day time driving:

Once in setup and in the "LIGHTING" setup menu, Press and release SW1 until "LIGHTING DAY LEVEL" is displayed

Press and hold SW1 to enter the day time brightness adjustment until a screen that says "DAY LEVEL ADJUST --" is displayed, then release the switch

A screen that reads "DAY LEVEL ADJUST XX", where xx is the current level, should be displayed.

Press and release SW1 to select desired brightness for gauges, the number is adjustable from 0 (all off) to 32 (LCD only) and then full backlight diming from 31- 01. Setting this to a number other than 0 will turn on the back lights even when the DIM terminal isn't powered, Setting to 32 will only enable the LCD message backlights.

Next press and release SW2 to save setting. Yes you have to use SW2 to save.

Exit lighting setup (DONE)

This will allow you to exit the lighting setup menus and go on to the next setup menu.

When "LIGHTING DONE" is displayed press and hold SW1 until "DONE" is displayed
Release the switch to go on to the next menu.

BUS INTERFACE MODULE SETUP

The bus interface modules (BIM) are an add-on product to Dakota Digital instrumentation systems. They allow you to add auxiliary gauge functions, such as fuel pressure, vac/boost, trans temp, etc., right into the system without having to add additional gauges. By default, all of the BIM readings are displayed on the tachometer/LCD2 message display where the tachometer and other performance readings are currently displayed. Switch 2 (SW2) is used to cycle through the various message screens.

More detailed instructions are supplied with the BIM units.

DISPLAY SETUP MENU

The VHX system allows for complete user adjustability, this includes allowing you to decide which reading you would like to display in the LCD message centers and which one you want it to display in. Various readings can be turned on or off, allowing you scroll though the message screens quicker, if desired, in normal operation. You can also enable a second set of indicators for turn signals, high beam, and cruise so they are seen more easily in two places on the dash, in the face and in the message center.

Press and hold SW 1 while turning the key on. Release the switch. Press and release SW1 to get to the "SETUP DISPLAYS" menu. Press and hold the SW1 until the message changes, then release SW1.

Secondary indicator setup (INDICATORS)

This menu will allow you to select where the indicators are displayed and if you want them shown in the face of of the system, light only, or if you would like them also displayed in the LCD1 message center as well as the face so they are more visible in two locations.

When "DISPLAYS INDICATORS" is displayed, press and hold SW1 until the message screen changes

Release SW1, and the current setting will be displayed as "INDICATORS" "LIGHT ONLY" or "LIGHT + LCD"

Press and release SW1 to change the value from "LIGHT ONLY" which only displays the indicators for turn signal, high beam, and cruise in the indicator light on the gauge face, or "LIGHT + LCD" that enables a secondary set of indicators in the LCD1 message screen.

When the desired value is displayed, press and hold SW1 until "DONE" is displayed
Release the switch to go on to the next menu item.

Display message location (LOCATION)

This menu will allow you to select which LCD message center you want to display the various readings on. You can select LCD1 (1), LCD2 (2), or both LCD1 and LCD2 (1+2) or shut the reading off by selecting OFF.

When "DISPLAYS LOCATION" is displayed, press and hold SW1 until the message screen changes

Release the switch, and the message screen will read "SCANNING... CH XX" it is looking for any additional messages that would need to be displayed from any attached BIM modules.

Once scanning is complete the LCD message screens should be lit with the messages "LCD1" and "LCD2" on the screens. This is to provide a reference of which LCD is which screen. Once you start selecting display options, selecting "1" will only show on LCD1, selecting "2" will only display on LCD2. You can also select both or none.

Press and release SW1; the screen will change and show any BIM channels first.

If no BIM modules are connected the display should read "ODOMETER 1" by default. This would mean that the odometer reading will be displayed on LCD1.

To make a change to the channel, press and hold SW1 until the LCD display number starts to flash, then release SW1.

Press and release SW1 to change the number from "1" "1+2" "2" or "OFF"

Once at the desired number press and hold SW1 until the display number stops flashing to save the positing, then release the switch.

Press and release the SW1 to go to the next message, continue on through all messages selecting which screen you want to display on or disable readings that you don't care to view by selecting "OFF"

When "LOCATION DONE" is displayed, this is the end of the location menu. Press and hold SW1 until "DONE" is displayed to exit and return to the setup menu.

NOTE: In normal operation you have to use switch 1 (SW1) to scroll through all of the LCD1 message screens. You will use switch 2 (SW2) to scroll through all of the LCD2 message screens. A press and hold of the appropriates will zero or reset the current reading, if it can be reset, such as trip counters and various performance timers.

INFORMATION MENU

The information menu, "INFO" is used to display software code information should you have any troubles; this information can be useful for troubleshooting as well verifying the current speedometer calibration value if using the normal speed input (SPD SND).

To view version of software your instrument system has, press and hold SW 1 while turning the key on. Release the switch. Press and release SW1 to get to the "INFO" setup menu. Press and hold SW1 to enter menu. `VERSION` should be the first option, press and hold SW1 to view version of software your instrument system has.

The version screen should be displayed as

<code>C Ux01.00x</code>	(this line is the controller)
<code>D Vh01.00x</code>	(this line is the display)

Press and release SW1 to exit back to the "INFO" menus.

To view the current pulse per mile (PPM) setting, press and hold the SW1 when "SPEED CAL" is displayed. The message screen should show "SPEED CAL xxxx" where xxxx is the current PPM setting/calibration value.

Press and release SW1 to exit back to the "INFO" setup menu.

When "INFO DONE" is displayed

Press and hold SW1 until "DONE" is displayed then release the switch to get back to the main setup menu.

ODOMETER PRESET MENU

The control box will allow you to set the odometer miles to match your current odometer reading, **ONE** time within the first 100 miles. **Once the odometer has more than 100 miles, this menu option will no longer be displayed. Make sure you have correctly calibrated your speedometer so you don't have to worry about racking up to many extra miles . Once you have preset the miles you cannot change it again without sending to the factory.**

Press and hold SW 1 while turning the key on. Release the switch. Press and release SW1 to get to the "SET ODOM" setup menu. Press and hold SW1 until "SET ODO MI" is displayed to enter the odometer setup menu, then release SW1.

The current miles will be displayed with the left most digit flashing.

Press and release SW1 to increment the digit. Press and hold the switch to move to the next digit to the right.

Continue on with a press and release to increment and a press and hold to advance until the right most digit has been set.

Press and hold SW1 and the speed display will show "XXXXXX MI SAVE? NO", release the switch.

If the value is incorrect press and hold the switch while "NO" is displayed to go back and change the odometer miles or turn the key off to cancel any changes.

If the value is correct press and release the switch to change to "XXXXXX MI SAVE? YES"

Press and hold the switch while "YES" is displayed to save the current odometer reading and return to the setup menus.

LCD MESSAGE CONTRAST ADJUSTMENT MENU

In some cases, mainly in systems where the message center would be mounted further apart from one another or at different angles in the dash, you may want to adjust the contrast of the LCD for better visibility. By default the contrast is set about midway and this setting should be acceptable for most applications, but you can change it for individual preference.

The contrast menu is a hidden menu since it typically shouldn't need adjustment, to get to the menu:

Press and hold SW1 while turning the key on. Release the switch.

The LCD1 message should display "SETUP SPEED" and the LCD2 message should read "SETUP". To access the hidden contrast menu, press and hold SW2 until "CONTRAST ADJUST" appears on both LCD screens, then release SW2.

Now if you press and hold SW1 a contrast bar will display and the contrast will change while the switch is held, the next press and hold of SW1 will decrease the value. You can continue with the press and hold and release to scroll up and down and adjust the contrast to your liking.

Once happy with the setting; release the switch and the screen will go back to "CONTRAST ADJUST" after there is no switch press for about three seconds.

If you have two LCD message centers use SW2 to adjust the contrast on LCD2 following the same method as above.

After no switch presses for about ten seconds, contrast adjust mode will be exited and you will be returned to the next main setup menu. If you are unhappy with the contrast, simply press and hold SW2 to access the menu again from any one of the main setup menu screens.

NORMAL OPERATION AND FUNCTION

Here we will describe the common functions and "normal" operation of the VHX system. Please follow the wiring and setup instructions to insure you have your system calibrated and connected properly for your application. Avoiding setup or selecting incorrect options will cause the gauge readings to be incorrect.

All of the VHX systems have the obvious gauge sweeps, but the biggest difference between the VHX series and other analog style gauges are the information or message displays. Each VHX system has two message displays, although some systems may have one large display. Display 1 is typically in the speedometer gauge or under it in dual display systems and display 2 is usually under the tachometer. For systems with a larger single display message center, the top half of the large display is considered display 1 and the bottom half display 2.

The message displays can display a wealth of auxiliary information as well as warning messages and even 16 additional channels with the use of the separately purchases BIM units, bus interface modules.

You must wire the momentary push button switches in order to access the different message screens. The message displays are accessed using the supplied push-button switches. Switch 1 (SW1) will toggle between the speed/LCD1 message displays and Switch 2 (SW2) will toggle between the tach/LCD2 message displays. The switches must be wired to access setup menus so it is recommended that you mount them in an easily accessible spot.

By default the available messages for each message display are:

Speed/LCD1 message displays	DESCRIPTION
ODOMETER	Odometer mileage (0-999,999)
A MILES	Trip A odometer mileage (0-9999.9)
B MILES	Trip B odometer mileage (0-9999.9)
KM/H	Alternate speed unit conversion
GEAR (with optional GSS-2000)	Gear shift position indicator
SERVIC (when enabled)	Miles since last service (0-9,999, or ---- when past due)
ENGINE	Check engine indicator
BRAKE	Brake warning indicator
4W DRV	4 wheel drive indication
WAIT	Diesel wait to start indicator

NOTE: In normal operation you have to use switch 1 (SW1) to reset trip meters, and service counter. A press and hold will zero the current reading, if it can be reset. A press hold will also clear warning messages such as ENGINE, BRAKE, etc.

Tach/LCD2 Message displays	DESCRIPTION
CLOCK	12 hour clock display
HOURS	Hours system has been on with tach signal (0-999.9)
HI SPEED	High speed recall (0-255)
0-60 MPH	0-60 mph time in seconds (0-25.5)
1/4 MI SPD	Vehicle speed at end of 1/4 mile
1/4 MI TIME	Time to travel 1/4 mile from standing start
RPM	Digital tach readout on message display
HIGH RPM	High rpm recall (0-18,000)
Future BIM displays(optional)	BIM messages will display on message 2 display by default

NOTE: A press and hold of SW2 will zero the current reading, if it can be reset.

If you have the system powered up in normal mode you can scroll through the various display screens with the press and release of the switches, SW1 or SW2. Whatever screen you were on last will be recalled at the next power up. You can also select which screen you want certain messages to appear on or if you want them displayed at all (covered under display setup).

If a warning limit or a change is sensed, the display screen may switch to that screen as a warning indicator if it isn't already being displayed. This is also true for systems that have the optional gear position sensor installed; if the gear message isn't displayed, whenever there is a gear change the current gear screen will pop-up to indicate the gear change and after about three seconds, revert back to the previous displayed message.

TROUBLESHOOTING GUIDE

This is a list of some problems and their solutions which may be encountered when installing your instrumentation system. If you cannot determine what the problem is or how to solve it, please call our technical assistance line (605) 332-6513 or email dakotasupport@dakotadigital.com.

*** A note on vehicle grounding ***

The most common cause of problems with electric gauges and other sensitive vehicle electronics is poor ground connections. The engine block has the highest ground currents of any point in the vehicle. The ignition system, electric gauge senders, starter, alternator, etc. all use the engine block for a ground point. Since the alternator is grounded directly to the engine block, all ground currents in the entire vehicle must pass through the engine block while the engine is running. A weak or loose connection can cause many unexpected problems that may be difficult to track down. The engine block should have heavy ground straps to **both the chassis and the body**. The main **negative cable from the battery should be connected directly to the engine block**.

Symptom	Possible Problem	Solution
System does not turn on and status LED is off.	Control box may not be getting power.	Check if the control box always has 12 volts connected to it's constant power terminal and 12v to ACC power terminal when the key is on.
	Control box may not be getting a ground.	Check if the control box has a proper ground connection. Do not use a battery charger to power the system.
	The control box may have an internal problem	Contact Dakota Digital's service department with a description of the problem.
System does not turn on and LED flashes once every 4 seconds.	Constant power connected but no ignition signal at ACC power terminal.	Check connection at ACC power terminal. There should be 12v when key is on, and 0v when key is off.
System does not turn on and LED is on steady.	Control box may be getting too low of a voltage.	Check if power to control box is at least 11 volts. Do not use a battery charger to power the system.
System does not turn on and LED is flashing.	The display system may not be getting power.	Check the patch cable between the display system and control box. Be sure the connectors are plugged in control box and display securely. Check the display system wiring harness for broken or cut wires.
The tachometer will not show a reading.	The control box is not connected to the engine properly	Make sure the control box is connected to your particular ignition system properly.
	The engine cylinder setting is incorrect.	Refer to the tach setup section of the installation manual.
	The tach signal setting is incorrect.	Refer to the tach setup section of the installation manual.

Symptom	Possible Problem	Solution
The tachometer reading is incorrect.	The tachometer signal wire is loose or broken. The engine cylinder setting is incorrect.	Check the connections at both ends of the wire. Refer to the tach setup section of the installation manual.
The speedometer will not show a reading.	The speed sending unit is not connected to the control box properly. The speed sending unit being used is not compatible with the control box. The speed sending unit is not connected to the transmission properly. The sending unit wire is picking up noise from nearby wires.	Check that all speed sending unit wires are connected to the control box properly. Use the speed sending unit supplied with the display system. Check that sender is mounted properly. Check that transmission has the appropriate internal parts. Isolate the sending unit wire from motor and ignition wires.
The speedometer is reading too fast or too slow.	The speedometer is not calibrated.	Refer to the Speed Calibration section of the installation manual.
With the engine running and the vehicle sitting still, the speedometer reads higher than zero.	A tachometer wire is too close to the speed sensor wire. There is a ground problem between the speed sensor and the control box.	Reroute or isolate the tachometer wire away from the speed wire. Make certain the ground wire for the speed sensor is connected directly to the control box ground.
A display shows "EE"	Sending unit for that gauge is not connected to the control box. Sending unit is not getting grounded. On the water or oil, the sending unit is not the correct type. On the fuel, the control box may be set for the wrong fuel sender.	Check the wire from sending unit to the control box for breaks. Make sure that the sending unit is wired to the correct terminal. Make sure the sending unit is grounded properly at the control box. Use the water and oil senders that were supplied with the system. Refer to "Fuel Setup" section of the installation manual to ensure that the settings match your fuel sender.
A display shows "- -"	The sending unit wire for that gauge is shorted to ground.	Repair or replace shorted wire.
Fuel displays " ? " and gauge stays at empty.	The control box is set to an invalid fuel sender setting.	Refer to "Fuel Setup" section of the installation manual to ensure that the settings match your fuel sender.

Symptom	Possible Problem	Solution
The fuel guage reads backwards, incorrectly, or does not change.	The control box may be set for the wrong type of fuel sender.	Refer to "Fuel Setup" section of the installation manual to ensure that the settings match your fuel sender.
	The fuel sender may not be connected to the control box properly.	Check the connections at both ends of the fuel sender wire. Make sure the fuel sender is grounded properly.
	The fuel sender may not be operating properly.	Check the fuel sending unit with an electrical multi-meter.
	The fuel sender may have a non-standard resistance range.	Use the custom fuel sender setup. See the Fuel Setup section of the manual for instructions.
The oil or water reading is incorrect.	The engine block may not be grounded to the chassis frame or body properly.	Use heavy ground cables from the battery to the engine block. Make sure both ends of the cable have clean metal-to-metal connections. Use a braided ground strap to ground the engine block to the chassis. Use a large braided ground strap to ground the engine block to the body or firewall.
	The sending units are not grounded at the control box.	Make sure wires are in correct terminals.
	The sending unit wire is picking up noise from nearby wires.	Isolate the sending unit wire from motor and ignition wires.
	The sending unit is not compatible with the control box	Use the sending unit provided with the display system.
The gear shift indicator does not light up.	The optional gear shift sending unit is not connected to the control box.	Connect the sending unit to the control box using the instructions supplied with the sending unit.
The gear shift indicator does not operate properly.	The gear shift decoder is not connected properly, or programmed correctly.	Check the connections to the transmission linkage and to the control box. Check gear shift decoder Installation manual.
The internal turn signal and high beam indicators do not light up.	The control box is not connected to the vehicle's electrical system properly.	Check the wires connected to the HIGH, LEFT, and RIGHT terminals on the control box.
The check engine indicator does not operate properly.	The control box is not connected to a TPI control module.	This feature is designed to work with engine control systems that provide an active low signal.

Symptom	Possible Problem	Solution
The check engine indicator stays on all of the time.	The Engine Control Module (ECM) needs to see the load of a light connected to it.	Connect a light or similar load to the ECM along with the control box.
The Function switches do not operate properly.	The push-button switches are not connected to the control box. The wrong type of switch is being used.	Momentary push-button or toggle switches must be connected to the SW1 and SW2 terminals as described in the manual. The switch terminal connected to the control box should normally be open. When the the switch is activated, the terminal should make contact to ground.
The display system starts up in the demonstration mode and remains in it.	Sw 2 terminal is constantly connected to ground.	Disconnect or replace the SW2 switch.
The clock doesn't keep time.	Constant power terminal is losing power.	Ensure constant power terminal has 12v even when key is off.
Display is to dark or light.	Contrast need to be adjusted.	See manual for contrast adjusting instructions.

SERVICE AND REPAIR

DAKOTA DIGITAL offers complete service and repair of its product line. In addition, technical consultation is available to help you work through any questions or problems you may be having installing one of our products. Please read through the Troubleshooting Guide. There, you will find the solution to most problems.

Should you ever need to send the unit back for repairs, please call our technical support line, (605) 332-6513, to request a Return Merchandise Authorization number. Package the product in a good quality box along with plenty of packing material. Ship the product by UPS or insured Parcel Post. Be sure to include the RMA number on the package, and include a complete description of the problem with RMA number, your full name and address (street address preferred), and a telephone number where you can be reached during the day. Any returns for warranty work must include a copy of the dated sales receipt from your place of purchase. Send no money. We will bill you after repair.

Dakota Digital Limited Lifetime Warranty

DAKOTA DIGITAL warrants to the ORIGINAL PURCHASER of this product that should it, under normal use and condition, be proven defective in material or workmanship for the lifetime of the original vehicle it was installed in, such defect(s) will be repaired or replaced at Dakota Digital's option.

This warranty does not cover nor extend to damage to the vehicle's systems, and does not cover removal or reinstallation of the product. This Warranty does not apply to any product or part thereof which in the opinion of the Company has been damaged through alteration, improper installation, mishandling, misuse, neglect, or accident.

This Warranty is in lieu of all other expressed warranties or liabilities. Any implied warranties, including any implied warranty of merchantability, shall be limited to the duration of this written warranty. No person or representative is authorized to assume, for Dakota Digital, any liability other than expressed herein in connection with the sale of this product.



4510 W. 61st St. N., Sioux Falls SD 57107
 Phone: (605) 332-6513 Fax: (605) 339-4106
www.dakotadigital.com
dakotasupport@dakotadigital.com

©Copyright 2010 Dakota Digital Inc.

VHX-67C-CAM

Dakota Digital VHX Instrument Installation
For '67 and '68 Chevy Camaro and Pontiac Firebird systems

Your new VHX-67C-CAM kit should include:

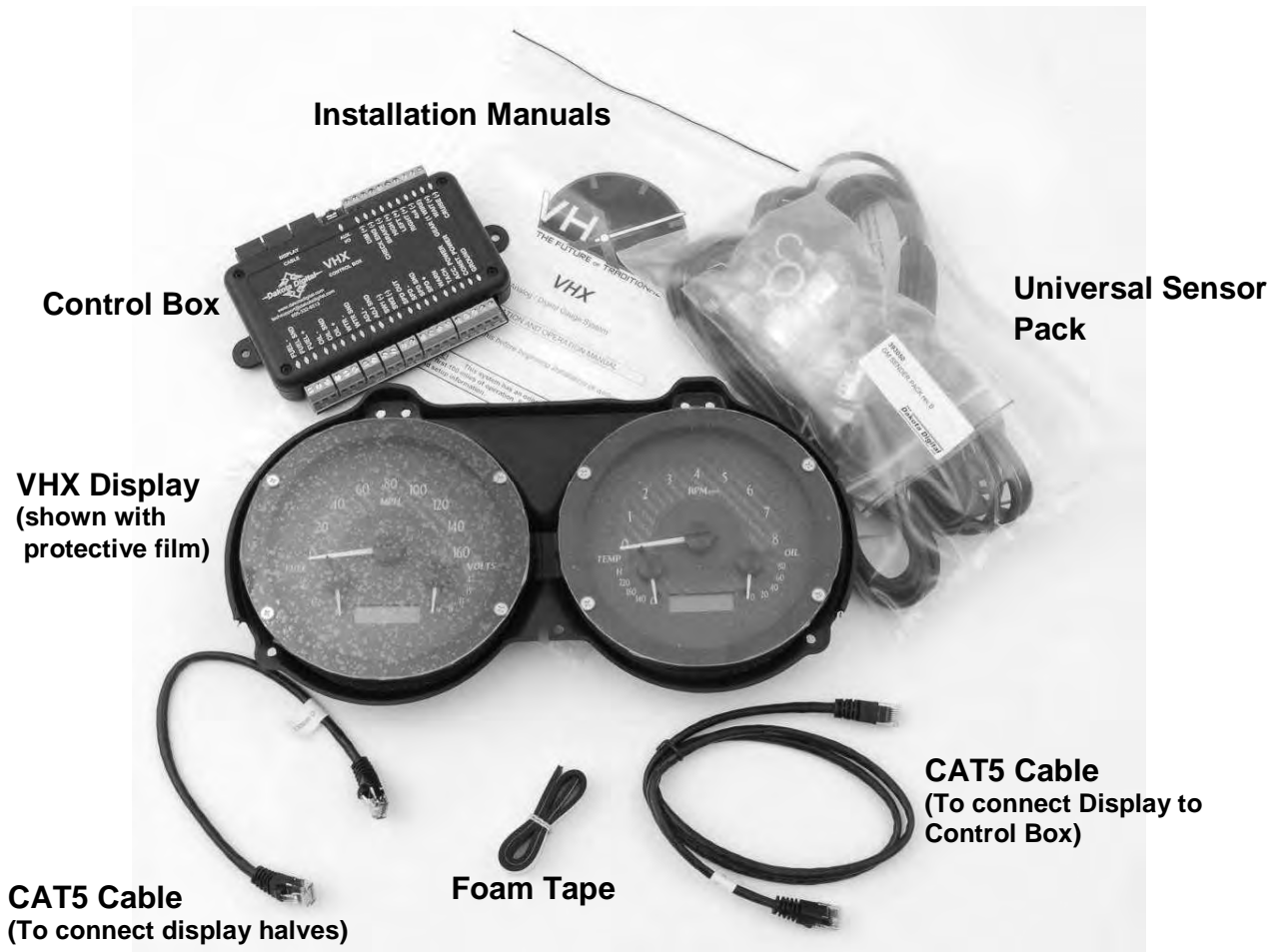

Installation

1. Remove the stock instrument cluster from the car.



2. Remove the five screws holding the gauges to the bezel on the back of the system.

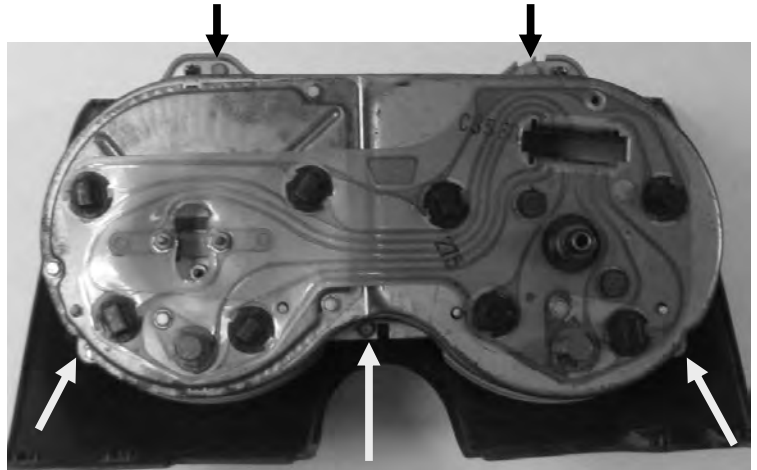

3. Remove the stock gauges and lens from the bezel.



4. For this step, you can re-use the stock foam blocks or use the supplied foam to make replacements for missing or brittle foam pieces. Cut the supplied foam into four small pieces, approx 1.5" long. There are four bosses molded in the bezel where the foam should be placed to help prevent any rattles of the lens and bezel.



On the top two locations, fold the foam over the edges and make sure its not sticking into the visible window. In the bottom two corners, the area for the tape is slightly narrower than the foam so you will need to ensure the foam is curved with the opening in the housing.

5. Remove the protective tape from the lens and install the VHX system into the bezel. Watch carefully as you insert the system so you don't scratch or damage the lens. The VHX system should align with the mounting bosses and screw locations in the bezel. Secure the VHX system to the bezel re-using the five original screws.

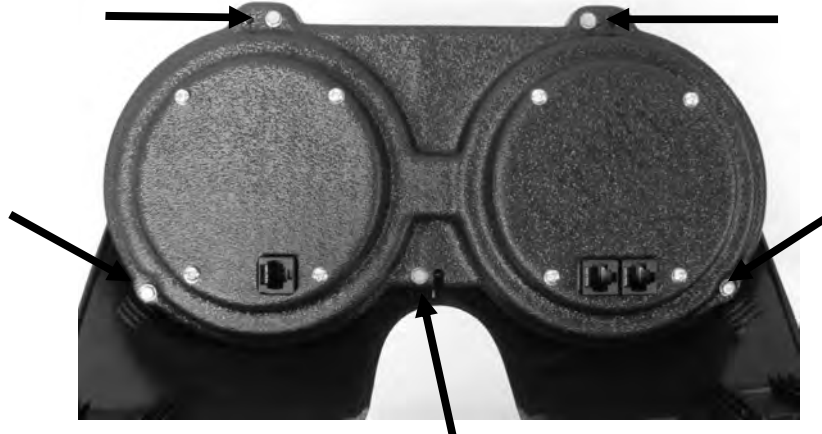

6. Re-install the cluster into the car and refer to the main manual for wiring instructions to complete the VHX installation.



4510 W. 61st St. N., Sioux Falls SD 57107
Phone: (605) 332-6513 Fax: (605) 339-4106
www.dakotadigital.com
dakotasupport@dakotadigital.com