



Overdrive Conversion Kits

This kit allows the use of your factory shifter with a TH700-R4 or TH200 4R transmission. Includes new laser cut and hardened detent, indicator plate, all hardware and all brackets to allow the use of your factory cable. You can barely tell it isn't factory!

S1041 1965-67 All*59.95 kit

Complete Kits

S105-DA 1968-72 2 to 3 Speed Conversion174.95 kit

S105-DB 1968-72 3 to 4 Speed Conversion174.95 kit

*It is recommended to use a longer rod when installing an overdrive transmission (# SW431)..... 49.95 kit



Turbo Hydramatic Shifter Conversion Kit

Perfect for installing a TH350 or TH400 in your early Nova! Now you can use your factory automatic floor shifter with a newer 3 or 4 speed automatic transmission! This kit retains the rod linkage and includes a new laser cut and hardened detent for proper stops and gear selection, a new matching transmission shift lever, all necessary hardware and instructions.

S1031 1965-67 All 3 Speed59.95 kit

S1041 1965-67 All 4 Speed59.95 kit

FTB-13433



Column Shift Transmission Bracket

Correct column shift transmission bracket which mounts on all column shift GM cars from 1969-1979.

FTB-13433 1969-79 11.99 ea.



SW435

TH Rod Linkage

Brand new rod linkage for your turbo hydramatic transmission.

SW435 All TH65.95 kit

Shifter Handle Spring

S501



Correct spring which mounts under the shifter handle for proper operation.

S501 All 7.95 ea.



S530

Kickdown Cable

Correct kickdown cable for all Novas with TH350.

S530 All TH350.....20.95 ea.

FSC-3914801



FSC-3895290

Steering Column Lockout / Bellcrank

Correct 1969-1972 Nova steering column lockout. Also fits 1968 Nova as a column shift bellcrank.

FSC-3895290 Powerglide..... 49.95 ea.

FSC-3914801 TH350/TH400 49.95 ea.



S531

Kickdown Bracket

Correct kickdown bracket for all small blocks.

S530KIT All Cable and Bracket Kit32.31 kit

S530 All Cable 20.95 ea.

S531 All Bracket 14.95 ea.



FKR-62

Lower Transmission Kickdown Rod

Used on all 1967-72 Novas with V8 engine and Powerglide. This mounts between the trans case kickdown arm and bellhousing mounted kickdown actuator arm.

FKR-62 All V8 w/ Powerglide..... 39.95 ea.



SW431

Rod Linkage Swivel Kit

When changing from a stock transmission to an overdrive unit, it is recommended that you use this longer rod.

SW427 1965-67 w/ PG or TH49.95 kit

SW418 Universal 18"..... 49.95 set

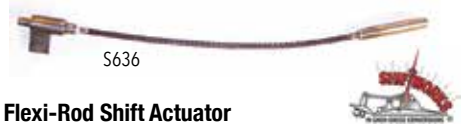

S636

Flexi-Rod Shift Actuator

This is a new Flexi-Rod shift actuator that will replace the original GM stamped spring-steel actuator found in 1968-72 Novas with automatic transmission and factory console shifters. Unlike the original which usually breaks over the years, this one is flexible. The bottom tangs are both hardened for years of use!

S636 1968-7257.95 ea.



FKR-666

Upper Transmission Kickdown Linkage Rod

Satin plated, exact reproduction comes complete with rod and swivel, from carburetor lever to bellhousing bellcrank.

FKR-666 1967-72 All with 2bbl 32.99 ea.

FKR-667 1967-70 All with 4bbl 32.99 ea.



FTH-973R

Shifter Cables

Original GM or high quality reproduction shifter cables for floor mounted TH shifter.

FTH-973 1968-72 GM..... 25.95 ea.!

FTH-973R 1968-72 Repro.....28.95 ea.



GCS-S6053

Stainless Steel Kickdown Cables

Show quality look with more adjustability than your factory cable.

GCS-S6053 TH350..... 41.99 ea.

GCS-S6051 TH700-R4 44.99 ea.

Note: For carburetor applications only.

EBC-22



Shifter Cable Clip

Correct gold clip for mounting cable.

EBC-22 Mounting Clip..... 2.99 ea.

FTH-049



Shifter Cable Clip

Correct push-on clip which mounts to shifter.

FTH-049 Push-on Clip (to shifter)..... 8.99 ea.



FSA-ZRLOS

Column Shift Linkage and Lockout Swivel Assembly

Correct swivel assembly for automatic column shift linkage and lockout.

FSA-ZRLOS 1968-72 19.95 ea.



FCB-1210

FCB-220



Cable Mounting Bracket

Correct bracket for mounting cable to tranny.

FCB-1210 1968-72 TH350 16.99 ea.
FCB-220 1968-72 TH400 21.99 ea.

FTH-050

FCB-222



FCB-322

Shifter Cable Lever Brackets

Correct cable lever brackets which mount to transmission.

FCB-322 1968-72 1st Design 19.99 ea.
FCB-222 1972-79 2nd Design 24.95 ea.
FTH-050 Mounting Stud (to bracket) 9.99 ea.

FCR-3920215



FCR-3914805

Steering Column Rods

FCR-3920215 1968-72 Upper PG 19.95 ea.
FCR-3972257 1968-72 Upper TH350/TH400 19.95 ea.
FCR-3945511 1968-72 Lower TH350 19.95 ea.
FCR-3914805 1968-72 Lower TH400 19.95 ea.
FCR-3895294 1968 Lower PG 18.95 ea.
FCR-3939743 1969-72 Lower PG 19.95 ea.



Transmission Cooler Lines

OE style reproduction transmission cooling lines with flared ends and correct nuts.

		OM	SS
XTC67NN	1962-67 700-R4 w/ Large Radiator	46.99 ea.	129.99 ea.
XTC6601	1966-67 Powerglide w/o Spacer at Radiator	46.99 ea.	77.99 ea.
XTC6603	1966-67 Powerglide, 3" Spacer at Radiator	46.99 ea.	77.99 ea.
XTC6803	1968-72 All Automatic w/ 12" Span	46.99 ea.	77.99 ea.
XTC7001	1968-72 All Automatic w/ 8" Span	46.99 ea.	77.99 ea.
XTC7401	1974 V8, TH350	46.99 ea.	77.99 ea.
XTC7501	1975 V8, TH350	46.99 ea.	77.99 ea.
XTC7603	1976-78 V8, TH350	60.99 ea.	77.99 ea.

Ships Oversize

Transmission Vacuum Lines

OE style reproduction transmission vacuum lines with flared ends and correct nuts.

		OM	SS
FTV6701	1967-69 Powerglide	30.99 ea.	41.99 ea.
FTV6703	1967-68 TH350 LH Modulator	30.99 ea.	41.99 ea.
FTV6705	1967 TH400	30.99 ea.	41.99 ea.
FTV6903	1969-70 TH350 RH Modulator	30.99 ea.	41.99 ea.
XTV6805	1968-72 TH400	29.99 ea.	40.99 ea.
XTV7401	1974 TH350	29.99 ea.	40.99 ea.
XTV7501	1975 TH350	30.99 ea.	30.99 ea.

Ships Oversize

GCS-S5047



Transmission Cooler Hose Kit

These flexible braided stainless steel transmission cooler hoses fit either single or dual pass cooler set ups. Includes fittings.

GCS-S5047 All Universal 119.99 kit
48" hose length.



FCM-RCNV-350

GForce Transmission Crossmembers

Whether you need extra exhaust clearance, or just want to make your car handle better, these crossmembers are for you!

FCM-RCNV-350	1962-67 Coupe TH350, Muncie, PowerGlide, T10, Saginaw	235.99 ea.
FCM-RCNV-400	1962-67 Coupe 200R4, TH400 Short Tail	235.99 ea.
FCM-RCNV-700	1962-67 Coupe 700R4, 4L60, Early 4L60E	232.99 ea.
FCM-RCF1-350	1968-74 TH350, TH200, Muncie, PowerGlide, T10, Saginaw	235.99 ea.
FCM-RCF1-400	1968-74 200R4, TH400 Short Tail	235.99 ea.
FCM-RCF1-700	1968-74 700R4, 4L60, Early 4L60E	235.99 ea.
FCM-RCF1-4L80	1968-74 4L800E, 4L85E	290.99 ea.
FCM-RCF1-T56	1968-74 GM T-56 (from a 93-97 F-body)	235.99 ea.
FCM-RCF2L-350	1975-79 TH350, TH200, Muncie, PowerGlide, T10, Saginaw	235.99 ea.
FCM-RCF2L-400	1975-79 200R4, TH400 Short Tail	235.99 ea.
FCM-RCF2L-700	1975-79 700R4, 4L60, Early 4L60E	235.99 ea.
FCM-RCF2L-4L80	1975-79 4L800E, 4L85E	290.99 ea.
FCM-RCF2L-T56	1975-79 GM T-56 (from a 93-97 F-body)	235.99 ea.

Note: Energy Suspension mounts are required with all GForce crossmembers. No Volume Discount.



FCM-85

Transmission Crossmember

OE style reproduction crossmembers for mounting your transmission.

FCM-85	1968-74 BB* TH400	59.95 ea.
FCM-85B4	1968-74 BB/4 Speed	139.95 ea.
FCM-85M	1968-74 TH350/4 Speed	79.95 ea.
BPC-7000	1968+ Bolt Kit (16 pc)	6.95 kit

**Must be used with 69-72 big block motor mounts and frame stands.*

FMCK-67S

Manual Transmission Conversion Kit
Planning on swapping from automatic to a 4 speed manual? This kit will take the headache out of the switch by providing you with all of the parts needed to make your conversion simple! This complete kit includes the brake/clutch pedals, Z bar, rods, boots, cross shaft kit, springs, bracket and all hardware!

FMCK-67S	1968 All SB.....	176.64 kit
FMCK-67S-HD	1968 SB w/ Headers.....	171.51 kit
FMCK-69S	1969-74 All SB.....	193.45 kit
FMCK-69S-HD	1969-74 SB w/ Headers.....	188.62 kit
FMCK-67B	1968 All BB.....	186.84 kit
FMCK-67B-HD	1968 BB w/ Headers.....	174.96 kit
FMCK-69B	1969-74 All BB.....	203.05 kit

No Volume Discount

FCA-5051

Clutch Linkage Kit
If you're looking to freshen up your original linkage but don't need the pedals, this is perfect!

FCA-5051	1968-74 SB.....	123.85 kit
FCA-5051-HD	1968-74 SB w/ Headers.....	119.02 kit
FCA-5053	1968-74 BB.....	133.45 kit
FCA-5053-HD	1968-74 BB w/ Headers.....	127.82 kit

FCI-1966

Clutch & Brake Pedal Assemblies
Complete reproduction brake/clutch pedals.

FCI-1962	1962-65 All.....	94.99 ea.
FCI-1966	1966-67 All.....	94.99 ea.
FCI-1869	1968-74 All.....	99.99 ea.

IBP-2065 IBP-4047
IHQ-0191 IBP-40471

Pedal Pads
OE style reproduction pedal pads.

IBP-2065	1962-67 Brake/Clutch Pad.....	5.99 ea.
IBP-4047	1962-67 Brake/Clutch.....	6.99 ea.
IHQ-0191	1968-74 Brake/Clutch Pad.....	4.95 ea.
IBP-40471	1962-67 All Power Brake w/ Manual Shift...	9.95 ea.

FPB-97 FPB-103

Clutch Pedal Bushing & Bumper
Correct nylon bushing used for ease of pedal.

FPB-97	All Bushing.....	1.99 ea.
FPB-103	All Bumper.....	3.95 ea.

FBF-606

Clutch Pedal Booster Rod & Clip
For use with power disc brakes.

FBC-799	Booster Rod Clip.....	6.99 ea.
FBF-606	Booster Rod Fork.....	14.95 ea.

NTR-235

Transmission Mounts

NPG-100	All Powerglide.....	11.95 ea.
NTR-235	All TH350/Manual.....	13.95 ea.
NTR-225	All TH400.....	13.95 ea.
BTE-7939	Mounting Bolt.....	0.95 ea.

3-1108G

Poly Transmission Mounts
Poly mounts outlast OEM mounts and are able to absorb most driveline vibrations.

3-1108G	1968-79 All Black.....	34.99 ea.
3-1108R	1968-79 All Red.....	34.99 ea.

ENERGY SUSPENSION
Performance POLYURETHANE Components

THIS IS AN EXCLUSIVE GROUND UP PRODUCT

BUY'N SAVE WITH KITS

FBH-621SUPERKIT



621 Bellhousing Kit

Complete kit with reproduction "621" bellhousing, clutch fork, fork boot, throw-out bearing, bolts and inspection cover. Fits cars with 11" clutch.

FBH-621SUPERKIT	Complete Kit.....	261.31 kit
FBH-621K	Bellhousing & Cover.....	174.93 kit
FBH-621	Bellhousing Only.....	169.95 ea.



FTE-3943

Flywheel Inspection Covers

OE style reproduction flywheel covers.

FTE-3943	Manual 11".....	24.95 ea.
NK-4497	Manual 10.5".....	23.99 ea.
NJ-088	All Powerglide.....	32.95 ea.
NE-810	All TH350.....	34.95 ea.
NJ-089	All TH400.....	93.99 ea.
BFW-506K	Bolts 4 pc.....	1.95 kit



BPB-9021

Bellhousing Hardware

BPB-9021	Bellhousing to Block 6pc.....	8.95 kit
BTE-307	Bellhousing to Trans 4pc 4 Speed.....	8.95 kit



FFW-105

Flywheels

Original GM flywheels.

FFW-105	10.5" w/o 454.....	279.99 ea.
HAYS-10-010	168t 57-85 SBC 65-70 BBC*.....	97.99 ea.
HAYS-10-020	168t 70-90 SBC BBC**.....	91.99 ea.
BPB-5116	1962-79 Flywheel to Crank Bolts 12pc.....	15.99 kit
BPB-5118	1962-79 Flex Plate to Crank Bolts 12pc.....	18.99 kit
BPP-8386	1962-79 Flywheel to Pressure Plate Bolts 12pc.....	10.99 kit

No Volume Discount. *Internally balanced. **Externally balanced.



FCK-258

Heavy Duty Clutch Kits

HD clutch kits include clutch disc, pressure plate, throw out bearing, pilot bushing, alignment tool and grease pack.

FCK-258	11" 10 Spline BB.....	210.95 kit
FCK-260	11" 26 Spline BB.....	219.95 kit
FCK-105	10.5" 10 Spline SB.....	199.95 kit
FCK-108	10.5" 26 Spline SB.....	199.95 kit

No Volume Discount

FPB-66ROLLER



Pilot Bushing

Correct GM needle bearings for input shaft.

FPB-ROLLER	All Roller.....	21.99 ea.
FPB-667	All Brass OE Style.....	13.95 ea.



FTO-641

Throw Out Bearing

Original OEM throw out bearing.

FTO-641	All.....	44.95 ea.
---------	----------	-----------



FTE-9000-ADJ



FTE-9000

Clutch Fork Ball

Clutch fork mounting ball for inside of bellhousing.

FTE-9000	All.....	13.95 ea.
FTE-9000-ADJ	Adjustable.....	29.95 ea.



FKW-4999

Clutch Fork Boot

Original clutch fork dust boot.

FKW-4999	1968-74 All.....	8.95 ea.
FKW-11LW	For Lakewood Scatter Shield Bellhousing.....	31.99 ea.

Centerforce Clutches & Flywheels

Whether you are building a street cruiser or a high powered drag race car, Centerforce clutches and flywheels will get you down the road reliably. With kits ranging from your basic entry-level performance clutch, to their radical twin disc kits, Centerforce offers the kit for you.

Steel Flywheels

Centerforce steel flywheels are manufactured from high quality billet steel and match closely to the original equipment flywheel weight. Please make sure to double check application before ordering.

700120	11" 168 Tooth, Internally Balanced Engines 454 BB 33 in/oz	298.99 ea.
700140	11" 168 Tooth, Externally Balanced Engines	381.99 ea.

Flywheels for externally balanced engines have a 23.4 in/oz. counter balance.

Centerforce I Clutch Kits

The Centerforce I Clutch Series is designed as a high-quality entry-level performance clutch for those in need of a superior stock replacement. Please make sure to double check application before ordering.

KCF523516	1966-70 396ci, 168 Tooth, 11" Clutch, 10 Spline	334.99 kit
KCF523516	1967-70 350ci, 168 Tooth, 11" Clutch, 10 Spline	334.99 kit
KCF523516	1970 400ci, 168 Tooth, 11" Clutch, 10 Spline	334.99 kit
KCF523516	1972 402ci, 168 Tooth, 11" Clutch, 10 Spline	334.99 kit

Centerforce II Clutch Kits

The Centerforce II Clutch Series utilizes a full facing disc with premium friction materials and a pressure plate with patented centrifugal weights (where applicable). Furthermore, static clamp load is increased via a patented machining processes; this combination allows superb holding power and maximum clutch life, making this clutch ideal for selected street/strip applications. Please make sure to double check application before ordering.

KCFT355216	1966-70 396ci, 168 Tooth, 11" Clutch, 10 Spline.....	404.99 kit
KCFT355216	1967-70 350ci, 168 Tooth, 11" Clutch, 10 Spline	404.99 kit
KCFT355216	1970 400ci, 168 Tooth, 11" Clutch, 10 Spline	404.99 kit
KCFT355216	1972 402ci, 168 Tooth, 11" Clutch, 10 Spline.....	404.99 kit



KCFT355216



N171

Centerforce Accessories

N1716	Throw-out Bearing, All	47.99 ea.
-------	------------------------------	-----------

HAYS-92-1003

Hays Manual Clutches

Hays Street 450 single disc kits are an excellent upgrade offering up to 30% more holding power over your stock clutch. Designed to handle stock to mildly modified engines up to 450 horsepower. This is a great clutch where drivability is the most important factor along with a stock pedal feel.

HAYS-91-1003	10.5" 26 Spline	295.99 kit
HAYS-91-1002	10.5" 10 Spline	292.99 kit
HAYS-91-1004	11" 10 Spline	302.99 kit
HAYS-91-1005	11" 26 Spline	302.99 kit

Hays Street 650 single disc kits are designed to handle highly modified naturally aspirated engines up to 650 horsepower. Designed as a true street/strip clutch for spirited high performance driving or frequent track use.

HAYS-92-1003	10.5" 26 Spline	586.99 kit
HAYS-92-1002	10.5" 10 Spline	565.99 kit
HAYS-92-1004	11" 10 Spline	601.99 kit
HAYS-92-1005	11" 26 Spline	596.99 kit

No volume discount.



HAYS-10-010



Hays Automatic Flexplate

Hays heavy duty Flexplate for high performance competition Chevy engines are constructed of a thicker than stock steel plate. This enables them to withstand the stress of high-stall torque converters and high-RPM engines. These flexplates are supplied with a ring gear that is securely welded in place and feature a dual bolt pattern for use with a Powerglide or Turbo style torque converter.

HAYS-10-010	168t 57-85 SBC 65-70 BBC*	97.99 ea.
HAYS-10-020	168t 70-90 SBC BBC**	91.99 ea.

*Internally balanced. **Externally balanced.
No volume discount.



BM-20230



B&M Automatic Flexplate

Heavy duty flexplate for extreme racing or street applications. SFI certified for NHRA & IHRA.

BM-20230	55-85 168t SBC up to 1991 BBC ...	112.99 ea.
BM-20232	55-85 168t SBC 400	120.99 ea.
BM-20233	55-85 168t BBC 454	109.99 ea.
BM-20232	55-85 153t SBC.....	120.99 ea.

*Except SBC 400 and BBC 454. No volume discount.

Lakewood Bellhousing

The Lakewood 15000LKW bellhousing connects Chevy small and big block engines to transmissions utilizing the standard GM pattern such as the Muncie, Saginaw, Borg Warner T10 and Tremec TKO transmissions. This bellhousing is hydro formed to fit '58-'87 GM full and midsize cars, 67-81 F-body vehicles and 68-79 Novas. This bellhousing is S.F.I. 6.1 certified which is required by many sanctioning bodies for cars running 11.49 or faster in the quarter mile. The Lakewood 15000 comes complete with engine block plate and Grade 8 mounting hardware.

LW-15000LKW	1962-1979 SBC, BBC	535.99 ea.
FEH-397	1968-1979 All Resto Clutch Fork	52.99 ea.
FKW-4999	1962-1979 All Clutch Fork Boot OE.....	8.95 ea.
FKW-111LW	1962-1979 All Clutch Fork Boot	31.99 ea.
FTE-9000-ADJ	1962-1979 All Adjustable Clutch Fork Ball	29.95 ea.

No volume discount.



FKW-111LW

FKW-4999

FEH-397

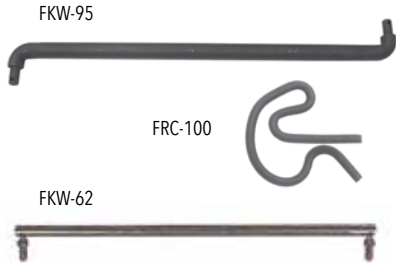

Clutch Firewall Rods

FKW-62	1962-67 All	33.95 ea.
FKW-95	1968-74 All	19.99 ea.
FRC-100	Attaching Clip	2.99 ea.



Firewall Rod Boots

OE style reproduction rubber boots for firewall.

FRB-1	1962-67	33.95 ea.
FHQ-0239	1968-74	6.99 ea.
FHQ-0891	1975-79	17.95 ea.

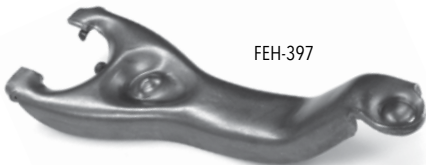

Clutch Fork

New GM clutch fork.



FCF-3583	1962-67	39.95 ea.
FEH-397	1968-74	52.99 ea.



Clutch Cross Shaft Kit

Original GM stud balls, nylon seats, protective felts, retaining clips, nuts and washers.

FPX-828	Complete All V8	29.95 kit
FPX-6568	Block Ball Only	13.95 ea.
FPX-5289	Frame Ball Only	20.99 ea.
FPX-3349	Plastic Seat Only	2.95 ea.
FPX-3360	Ball Felt	12.99 ea.
FPX-0696	Retaining Clip	1.99 ea.
FPX-33K	Cross Shaft Seat & Seal Kit	29.46 kit

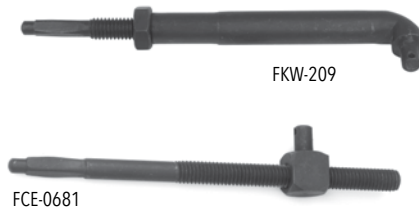

Clutch Adjustment Rod Kits

FKW-3	1962-67 SB	33.95 ea.
FKW-209	1968-74 SB	19.99 kit
FCE-0681	1968-74 BB	19.99 kit
FRC-100	Clip	2.99 ea.



Clutch Return Springs

Original return springs for clutch fork, etc.

FKW-1461	1968-74 SB	5.99 ea.
FPC-520	1968-74 BB	6.99 ea.



Clutch Spring Extension Rod

Correct clutch spring extension rod for small blocks.

FKW-1460	1968-74 SB	6.99 ea.
----------	------------------	----------



Block Conversion Pivot Bracket

Allows the stock clutch linkage to be used with non-Chevy II specific blocks.

FCB-30	1962-67	25.95 ea.
--------	---------------	-----------

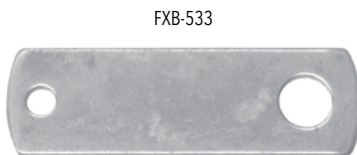

Clutch Fork Return Spring Extension

Correct clutch spring extension plate for big blocks.

FXB-533	1968-74 BB	6.99 ea.
---------	------------------	----------



Clutch Z Bar

OE style reproduction "zerk" bar.

FCI-3523	1962-67 SB	54.95 ea.
FCI-501	1968-74 SB	38.99 ea.
FCI-108	1968-75 BB	49.99 ea.



Clutch Frame Brackets

Correct bracket for mounting Z bar to frame.

FB-62	1962-67 All	23.95 ea.
FK-130	1968-74 All	12.99 ea.
BFB-605	Attaching Bolt	0.75 ea.



Reverse Lockout Kit

Complete with 2 rods and swivel mechanism.

NA-578	1969 All	84.95 kit
--------	----------------	-----------



BM-80675



BM-80706



HURST-3838530



BM-80690



BM-80840



HURST-3160001



B&M Automatic Floor Shifters

From the originator of high performance manual shifters our line of performance, street and racing shifters for automatic transmissions won't let you down. With classic good looks and proven mechanical designs giving choices of either positive ratcheting actions or gated racing shifters, provide positive shifts guaranteeing you won't miss a shift when it counts.

Starshifter

Features include NHRA/ IHRA reverse lockout, backup light switch, neutral safety switch, polished T-handle. Cable operated for quick installation and accurate shifting.

BM-80675 All 2&3 Speed 231.99 ea.

Megashifter

The B&M Megashifter has it all, form, function and classic style. This all adds up to bring you a quality shifter that's been one of the most popular automatic shifters of all time. First off let's talk function. The Megashifter's positive ratcheting function won't allow you to over shift and miss a gear at that critical moment, along with the reverse lockout feature meets NHRA/IHRA safety rules for those weekend grudge races at the track. The look and feel of the T-handle and accordion style shift boot really shows off the racing heritage of the Megashifter.

BM-80690 All 2,3,4 Speed..... 372.99 ea.

BM-80694 1973-79 2,3,4 Speed..... 377.99 ea.

Quicksilver

The B&M Quicksilver features a ratcheting action for positive shifts, chrome knob, neutral safety switch, NHRA/IHRA approved reverse lockout.

BM-80683 All 2,3,4 Speed 337.99 ea.

BM-80688 1973-79 2,3,4 Speed..... 329.99 ea.

Hammer

The Hammer shifter may just be the most comfortable and versatile shifter available. The unique design of the shift handle easily fits all sizes of hands providing the best wrist angle and feel when shifting.

BM-80885 All 2,3,4 Speed..... 255.99 ea.

Pro Stick

The Original Pro Stick shifter delivers rock-solid performance, mixed with clean design cues and compact size. This is why you see so many Pro Stick shifters at the race track.

BM-80706 All 2,3,4 Speed..... 328.99 ea.

Stealth Magnum Pro Stick

The Stealth Magnum Grip Pro Stick shifter delivers rock-solid performance, mixed with clean design cues and compact size.

BM-81052 All 2,3,4 Speed..... 312.99 ea.

Pro Ratchet

The Pro Ratchet shifter is one of our most popular and easiest to operate race shifters. Features include a positive ratcheting design that self-centers the handle after each shift giving you maximum clearance behind the shifter and won't allow you to miss a shift by over-shifting a gear. This versatile shifter will operate both forward and reverse shift patterns.

BM-80840 All Silver 2 Speed Powerglide 331.99 ea.

BM-80842 All Silver 3,4 Speed* 331.99 ea.

BM-80843 All Carbon 3,4 Speed* 334.99 ea.

BM-81120 All Stealth 3,4 Speed* 414.99 ea.

*May require PRNDL switch for some applications. No volume discount.

Hurst Automatic Shifters

From the originator of high performance manual shifters, is our line of performance street and racing shifters for automatic transmissions that won't let you down. With classic good looks and proven mechanical designs giving choices of either positive ratcheting actions, or gated racing shifters providing positive shifts guaranteeing you won't miss a shift when it counts.

Pro-Matic 2

Ratchet-action shifter with its chrome-plated stick and black knob is quality engineered for years of precise, trouble-free operation. Once the shifter is installed, the textured console and brilliant top cover that can be trimmed to fit any floor contour integrates the shifter with the interior.

HURST-3838500 All 3 Speed 317.99 ea.

V-Matic 3 Shifter

Designed with a park and reverse lock trigger actuating system that allows smooth and flawless ratcheting through the forward gears.

HURST-3838530 All 3 & 4 Speed 369.99 ea.

Quarter Stick

The Quarter Stick shifter provides positive gear change control for both street and race applications. Its compact size fits easily in racecars with limited space and is very lightweight at only 2.5 pounds. Features include black oxide coated steel construction, 1018 hardened steel gate plate, forged aluminum shift stick with 7/16"-20 tpi and a classic white Hurst shift knob.

HURST-3160001 All 2 Speed* 319.99 ea.

HURST-3160006 All 3 Speed** 319.99 ea.

HURST-3160020 All 3 Speed* 322.99 ea.

*Reverse valve body. **Forward valve body.



HURST-5389020 HURST-5389023

Hurst Billet Shifter Handles

This is a great way to add a contemporary performance look to your muscle car. Billet Aluminum construction is precision CNC machined for a modern look and feel. Fits classic Hurst shifters with a 2 bolt pattern.

HURST-5389020	6" Straight	83.99 ea.
HURST-5389021	8" Straight	93.99 ea.
HURST-5389022	10" Straight	105.99 ea.
HURST-5389023	6" Lay Back	93.99 ea.
HURST-5389024	8" Lay Back	105.99 ea.
HURST-5389025	10" Lay Back	128.99 ea.

No volume discount.



HURST-5010002

Hurst Indy Manual Shifters

For the past 60 years Hurst has been the most recognized name in performance shifters.

HURST-5010002	Indy 3 Speed	285.99 ea.
HURST-5030030	Indy 4 Speed	419.99 ea.



HURST-3162001 HURST-3162023

Pistol Grip Quarter Stick

The Pistol-Grip Quarter Stick shifter provides positive gear change control for both street and race applications. Its compact size fits easily in racecars with limited space and is very lightweight at only 2.5 pounds. Features include black oxide coated steel construction, 1018 hardened steel gate plate, ergonomic billet aluminum pistol-grip shift handle that incorporates a momentary switch which can be used to activate a Hurst Roll control, a trans-brake or a nitrous system.

HURST-3162001	All Silver Handle 2 Speed*	419.99 ea.
HURST-3162002	All Black Handle 2 Speed*	419.99 ea.
HURST-3162006	All Silver Handle 3 Speed**	419.99 ea.
HURST-3162007	All Black Handle 3 Speed**	419.99 ea.
HURST-3162023	All Black Handle 4 Speed**	412.99 ea.

*Reverse valve body. **Forward valve body. No volume discount.

HURST-5008555



HURST-5000029

Hurst Shifter Cables

These premium quality cables feature a solid 303 stainless steel inner wire core encased within a nylon liner wrapped with helical lay wires and swaged ends for superior strength. The core is lubricated with Teflon prior to assembly and then sealed in a heavy plastic outer casing for a lifetime of durability and smooth operation.

Single eyelet on one end and threaded on the other end.

HURST-5000023	3 Feet	72.99 ea.
HURST-5000025	5 Feet	68.99 ea.
HURST-5000028	8 Feet	88.99 ea.

Single eyelet on one end and threaded on the other end. For Pro-Matic & V-Matic shifters

HURST-5008555	5 Feet	65.99 ea.
---------------	--------------	-----------

Eyelets on both ends for quarter stick.

HURST-5000029	5 Feet	76.99 ea.
---------------	--------------	-----------

No volume discount.



B&M Governor Recalibration Kit

This kit allows you to adjust the shift points of your transmission after it is installed in your vehicle. The Governor Recalibrating Kit is very useful if you have a vehicle that is very light; has a low rear-end gear ratio.

BM-20248	55-85 TH350, TH400, TH700R4	83.99 kit
----------	-----------------------------------	-----------

No volume discount.



BM-30228



BM-30229



BM-21042

B&M Transpak, Transkit & Master Overhaul Kits

The B&M Transpak has all the features in the Shift Improver Kit, plus it provides additional driver manual control. Retain full automatic features and standard shift points with selector in drive.

BM-30228	1968-79 TH350	97.99 ea.
----------	---------------------	-----------

B&M Transkits give you the same high-quality components that are used in all B&M Street and Strip transmissions. They also include special directions on how to modify your case, pump and components.

BM-30229	1968-79 TH350	285.99 ea.
----------	---------------------	------------

B&M Master Racing overhaul kits are supplied with all of the gaskets, seals, bushings and friction material required for a complete high performance or racing trans overhaul.

BM-21042	1968-79 TH350	241.99 kit
BM-21041	1968-79 TH400	262.99 kit

No volume discount

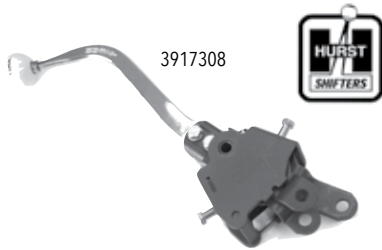

Hurst Shifters

New Hurst Competition Plus shifter complete with Hurst handle and shifter ball.

3917308	1964-67 All	360.91 ea.
3914339	1968 with Console.....	420.99 ea.
3916848	1968-73 w/o Console	414.99 ea.

No Volume Discount

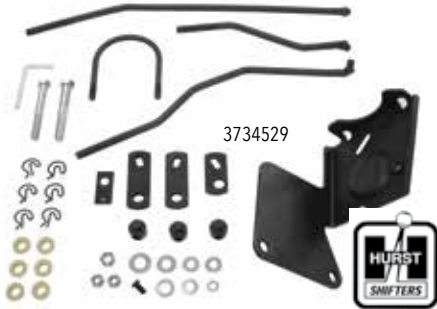

Hurst Installation Kits

Complete kit with rods, levers, swivels and hardware.

3733163	1964 All	211.99 kit
3734529	1968 All	223.99 kit
3737131	1969-70 w/o Console	228.99 ea.
3737834	1971-73 w/o Console	211.99 kit

No Volume Discount



Shifter Balls

OE style reproduction shifter balls.

FZ-1300	1965-67 White Bench.....	35.95 ea.
FZ-1400	1965-67 Chrome	24.95 ea.
FZ-1420	1968-72 White 5/16"	21.99 ea.
FZ-1424	1968-72 White 3/8".....	27.99 ea.
FW-115	Chrome 5/16"	24.99 ea.
FW-117	Chrome 3/8"	23.99 ea.
FW-157	Black/Chrome 5/16"	21.99 ea.
FW-159	Black/Chrome 3/8".....	21.99 ea.
FW-38HURST	Hurst White 3/8" 4 Speed.....	38.99 ea.



Hurst-T Handle Shifter Knob

This brushed aluminum t-handle provides a positive feel for accurate gear selection. A favorite in the performance world for years! Includes adaptors for most popular shift handles.

FW-HURST	T-Handle.....	37.99 ea.
----------	---------------	-----------



Shifter Handles

OE style reproduction chrome shifter handles.

FRZ-5134	1965-67 Bench.....	99.95 ea.
FZ-513B	1965-66 Bucket.....	99.95 ea.
FRZ-5131	1967 Bucket.....	119.95 ea.

Muncie - Hurst Adaptor

This handy bracket allows you to bolt up your original Muncie shifter handle to a Hurst shifter. The original Muncie handle featured a top mount design while the Hurst handle features a side mount design. The Hurst design is much stronger

FHB-64	1964-67.....	26.95 ea.
--------	--------------	-----------



1968-72 Auto Shifter

This shifter is complete with neutral safety/back up switch, all rod linkage components and factory-like reverse lock out and detents for each gear. Also includes a universal floor mounting bracket kit. It mounts to the floor and with much of the body below the floor to clear factory consoles.

SW280-RCT	1968-72 Universal Replacement.....	349.95 kit
-----------	------------------------------------	------------

CLAYTON MACHINE WORKS

SH-203-8 SH-202-8 SH-204-10

Billet Shifter Handles

These billet aluminum shifter handles from Clayton Machine work with any Hurst or Tremec, TK500/TKO600 2 bolt shifter mount and are a great finishing touch for your custom ride! Available in three styles. Basic black anodized, truss style with grey powder coat, truss style adjustable grey powder coat. Shift knob not included. Requires knob with 3/8"-16" thread. Same as most Hurst knobs.

SH-203-8	8" Black Anno 30 Degree Kick Back	169.99 ea.
SH-203-10	10" Black Anno 30 Degree Kick Back.....	175.99 ea.
SH-202-8	8" Grey PC Truss Style 30 Degree Kick Back	132.99 ea.
SH-202-10	10" Grey PC Truss Style 30 Degree Kick Back.....	137.99 ea.
SH-204-10	10" Grey PC Truss Style Adjustable Kick Back.....	228.99 ea.

No volume discount.

FMCASE-660

FMREBLD-6670

FMSYNCHRO-6674

FMBEARING-6374

Muncie 4-Speed Transmission Parts

Rebuild your Nova's damaged or broken M-20, M-21 transmission with these awesome rebuild kits, cases and synchros!

Rebuild Kits

FMREBLD-6465	1964-65 M-20, 21 137pc	175.95 kit
FMREBLD-6670	1966-70 M-20, 21, 22 169pc.....	175.95 kit
FMREBLD-7074	1970-74 M-20, 21, 22 169pc.....	175.95 kit

Cases

FMCASE-660	1968-70 M-20, 21, 22 Casting Number 3925660.....	319.95 ea.
FMCASE-661	1970-74 M-20, 21, 22 Casting Number 3925661.....	319.95 ea.

Parts

FMSYNCHRO-6674	1966-74 M-20, 21, 22 Synchro Assembly	66.95 kit
FMBEARING-6374	1964-74 M-20, 21, 22 Front Bearing.....	64.94 kit

No volume discount.



ITW-1022 ICE-4526

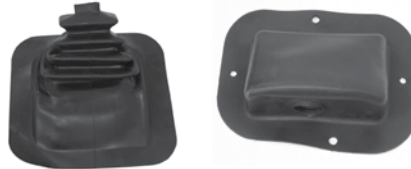

ITW-1057 ITW-1054

Shifter Boots

Brand new injection molded boots.

ITW-1022	1964-67 4 Speed	24.95 ea.
ICE-4526	1968-74 4 Speed Console	22.95 ea.
ITW-1057	1968-74 4 Speed w/o Console.....	29.99 ea.
ITW-1054	1968-74 Auto w/ Console	24.95 ea.
ICE-HURST	Universal	60.99 ea.
ICE-INDY	Universal Indy Shift Boot.....	27.99 ea.



ITW-1050 ITW-1100



ITW-1058

Shift Boot Retainers

Correct die stamped steel boot retainers.

ITW-1050	1962-67 All	22.95 ea.
ITW-1058	1968-74 w/o Console.....	45.95 ea.
ITW-1100	1968-74 w/ Console.....	22.95 ea.



S500

Neutral Safety Switch

This neutral safety switch is necessary when converting your early Nova to a TH or OD transmission.

S500	1962-65 w/ Console.....	54.95 ea.
------	-------------------------	-----------

GNS-13



Neutral Safety Switch

Correct steering column switch for proper engine and reverse light activation.

GNS-13	1962-66 Powerglide Column	39.99 ea.
GDR-411	1969-72 Automatic Console	21.95 ea.

GNS-1969



Neutral Start Switch

Correct safety switch located at the pedal to prevent the car from starting in gear.

GNS-1969	1969 Manual	59.95 ea.
FSR-372	1969 Rod & Clip.....	16.99 ea.
GNS-X99	1970-75 Manual.....	49.99 ea.

GNS-503



Neutral Safety Switch

For console shift automatic transmission equipped cars.

GNS-696	1965-67 Auto.....	61.99 ea.
GNS-503	1968-72 Powerglide	41.99 ea.
GNQ-375	1968-72 TH350/TH400.....	39.99 ea.
GNS-35	1969-72 Auto Column	16.99 ea.



39504

Reverse Switch Mounting Kit

Complete with bracket, shield, rod, clips and hardware for mounting the reverse switch.

39504	1964-68 Complete.....	42.95 kit
GRB-342	1964-68 Bracket Only	14.95 ea.
GWT-17	1964-68 Shield Only.....	9.95 ea.
GRR-58	1964-68 Rod/Clips Only	17.95 ea.

1993413



Reverse Lamp Switch

Correct switch assembly for activating reverse lamps.

1998728	1962 4 Speed	62.99 ea.
1997929	1963 4 Speed	62.99 ea.
1993661	1964 4 Speed	69.99 ea.
1993307	1965-67 4 Speed	69.99 ea.
1993413	1968 4 Speed	74.99 ea.

10665



Reverse Switch Extension Harness

Correct harness which plugs into firewall.

27315	1962-63 Auto	16.99 ea.
28160	1962 4 Speed	35.99 ea.
28335	1963 All Connector	22.99 ea.
10665	1967-68 All	23.99 ea.

REVSKIT-UNI



Universal Reverse Lamp Switch Manual

This kit allows you to add a reverse light switch to non-stock applications. If you have a Hurst shifter this kit is a must.

REVSKIT-UNI	All Manual.....	39.99 ea.
-------------	-----------------	-----------

BUY 'N SAVE WITH KITS



Reverse Switch Kit

This kit includes all components needed for a complete installation: Switch, extension harness, bracket, shield and rod.

REVSKIT-67X	1967	123.24 kit
REVSKIT-67F	1968	127.74 kit

No Volume Discount.

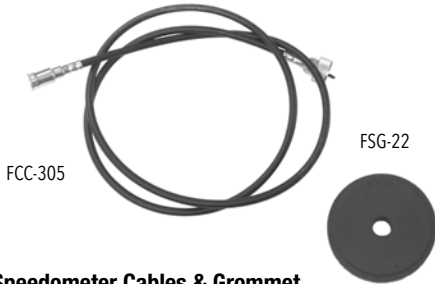

Speedometer Cables & Grommet

New complete cables with casings and correct ends ready to install.

FCC-201	1962-68 64"	18.95 ea.
FCC-203	1962-68 83"	18.95 ea.
FCC-305	1969-72 61"	18.95 ea.
FCC-205	1969-72 80"	18.95 ea.
FSG-22	1962-74 All Grommet	7.95 ea.

*Longer cables are for cars with passenger side screw ins on transmission.



Modulator Valve

Replacement modulator valve for automatic transmission.

FTM-12903	PG, TH350, TH400	39.95 ea.
-----------	------------------	-----------

Note: Smaller than original but functions the same.



Speedometer Cable Clip

Bolts to bottom of manual transmission tail shaft bolt to keep cable from hanging down.

FHB-13653	1970-79 Manual Trans	14.95 ea.
-----------	----------------------	-----------



Universal Driveshaft Loop

GCS-S7120	Universal	28.99 ea.
-----------	-----------	-----------



U-Joint Attaching Kits

Correct straps and bolts for attaching drive shaft to rear yoke.

BPU-337	All Straps with Bolts	16.99 kit
BPU-334	All U-bolts with Nuts	17.99 kit



Yokes

New front drive shaft & rear differential yokes.

FY-123	Front Yoke TH400	99.99 ea.
FY-935	Front Yoke TH350/4 Speed	99.95 ea.
FY-2122	1965-79 12 Bolt Strap Type	114.95 ea.



TCS Transmission Switches

Correct TCS switch located on transmission.

ATS-21MP	1970-75 Pin Style	32.95 ea.
ATS-21MS	1970-75 Spade Style	32.95 ea.



TCS Wire Retainer

Correct reproduction for Muncie.

ATS-653	1970-74 w/ Muncie	19.95 ea.
---------	-------------------	-----------



Tail Seals

Correct tail shaft yoke seals.

FTS-350	Powerglide	5.99 ea.
FTS-350	TH350	5.95 ea.
FTS-400	TH400	10.95 ea.



Tail Shaft Bolts

Correct TR head markings & black phosphate plating.

BSB-12925	PG, TH350, TH400 6pc	9.99 kit
-----------	----------------------	----------

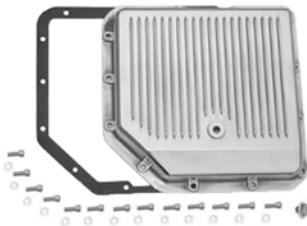

Polished Finned Transmission Pans

Show quality polished stock depth pan crafted from cast aluminum and polished to a bright finish. Includes gasket, drain plug and bolts.

GCS-S8491	TH350	52.99 ea.
GCS-S8492	TH400	62.99 ea.
GCS-S8493	TH700-R4	62.99 ea.



Chrome Transmission Pans

Stock depth. Chrome plated steel for a show quality finish.

GCS-S9074	TH350	19.99 ea.
GCS-S7599	TH700-R4	24.99 ea.



Chrome Finned Transmission Pans

Stock depth. Chrome plated steel with fins.

GCS-S9124	Powerglide	19.99 ea.
GCS-S9122	TH350	17.99 ea.
GCS-S9121	TH400	17.99 ea.
GCS-S9712	TH700-R4	24.99 ea.



Extra Capacity Finned Transmission Pans

Same quality show finish as our stock pans but with extra fluid capacity for better cooling.

GCS-S9197	TH400 1.5 Extra Qts.	20.99 ea.
GCS-S9196	TH400 2.5 Extra Qts.	28.99 ea.
GCS-S9197BK	TH400 1.5 Extra Qts. Black	20.99 ea.
GCS-S9198BK	TH350 1.5 Extra Qts. Black	20.99 ea.
GCS-S9712BK	700-R4 1.5 Extra Qts. Black	26.99 ea.



B&M Deep Transmission Pan Cast

These B&M automatic transmission deep pans provide additional fluid capacity and cooling ability. No modifications to the dipstick are needed. They include a drain plug for clean and easy fluid changes. Adds 2-3 quarts to the transmission.

BM-30280	All TH350, TH250 3 Qts.	190.99 ea.
BM-20280	All TH400 2 Qts.	173.99 ea.
BM-70280	All Powerglide 2 Qts.	184.99 ea.
BM-70260	All TH700R/H, 4L60/65E 3 Qts.	265.99 ea.

No volume discount.



Muncie M20, M21, M22 TH350, TH400

Transmission Speedometer Gears

These are the correct speedometer drive gears which go inside the transmission case. Please compare the gear you have to what you are ordering as the color or tooth count may vary from original. We do not have an application chart for these, so if changing axle ratios or tire size, please consult various online resources.

Muncie M20, M21, M22

Saginaw 3 & 4 Speed and Powerglide

FR-158RB	17 Tooth Purple	16.95 ea.
FR-158RD	18 Tooth Brown	16.95 ea.
FR-158RF	19 Tooth Natural	16.95 ea.
FR-158RH	20 Tooth Blue	16.95 ea.
FR-158RK	21 Tooth Red	16.95 ea.
FR-158RM	22 Tooth Gray	16.95 ea.
FR-158RS	23 Tooth Black	16.95 ea.
FR-158RV	24 Tooth Orange	16.95 ea.

TH350, TH375, TH400, TH475

FR-158SB	35 Tooth Pink	16.95 ea.
FR-158SD	36 Tooth White	16.95 ea.
FR-158SF	37 Tooth Red	19.95 ea.
FR-158SH	38 Tooth Blue	16.95 ea.
FR-158SM	40 Tooth Black	16.95 ea.
FR-158SP	41 Tooth Yellow	16.95 ea.
FR-158SS	42 Tooth Green	16.95 ea.
FR-158SV	43 Tooth Purple	16.95 ea.
FR-158SX	44 Tooth Dark Gray	16.95 ea.
FR-158SZ	45 Tooth Light Blue	16.95 ea.



BM-70264



B&M Transmission Coolers & Kits

B&M Super Coolers are 100% aluminum stacked plate style core which is ideal for additional transmission cooling. With oven brazed construction, this sturdy cooler design is practically impervious to flying rocks or other debris.

Small

BM-70265	All 7,500 BTU Polished	99.99 ea.
BM-70273	All 15,000 BTU Black	90.99 ea.

Medium

BM-70268	All 13,000 BTU Black	92.99 kit
BM-70266	All 20,500 BTU Black	124.99 ea.
BM-70272	All 20,500 BTU Polished	170.99 ea.

Large

BM-70264	All 14,400 BTU Black	108.99 kit
BM-70274	All 29,200 BTU Black	150.99 ea.

No volume discount.



BM-70298



B&M HiTek Cooling Systems

Hi-Tek Super Coolers are fitted with a high quality 12 Volt cooling. Suitable for many fluids including ATF, engine oil, differential oil and power steering fluid.

BM-70298	All 350 CFM Black	337.99 ea.
BM-70297	All 590 CFM Black	372.99 ea.

No volume discount.



FDT-350

GCS-S9422

Dipstick & Tubes

GM replacement dipstick and tubes.

FDT-350	TH350 Tube	21.95 ea.
FDT-400	TH400 Tube	21.95 ea.
FDS-3	TH350 Stick	9.95 ea.
FDS-4	TH400 Stick	9.95 ea.

Chrome Dipsticks and Tubes

Show quality dipsticks are an excellent upgrade to any engine compartment. Includes dipstick & tube.

GCS-S9422	Powerglide	13.99 ea.
GCS-S9421	TH350	12.99 ea.
GCS-S9421BA	TH350 Billet Handle	21.99 ea.
GCS-S4994	TH350 34"	13.99 ea.
GCS-S4994BA	TH350 34" Billet Handle	17.99 ea.
GCS-S4995	TH400 24"	10.99 ea.
GCS-S4995BA	TH400 24" Billet Handle	14.99 ea.



BM-70500

B&M Differential Covers

B&M Cast Aluminum Differential Covers are designed to strengthen the differential by preventing case distortion, ring gear & bearing cap deflection. Constructed of A356.0-T6 aluminum, these rugged covers significantly increase the fluid capacity and dissipate heat much faster than the stock factory unit to prolong the life of your ring and pinion gears.

BM-70500	12 Bolt 8.875" Ring Gear Silver	198.99 ea.
BM-70502	10 Bolt 8.2, 5, or 6" Ring Gear Silver	202.99 ea.
BM-71502	10 Bolt 8.2, 5, or 6" Ring Gear Black	221.99 ea.
BM-70503	10 Bolt 8.2" BOP Ring Gear Silver	181.99 ea.

No volume discount.



GCS-S4787

Custom Rear End Covers

Choose from high quality chrome or bright polished aluminum. A great finishing touch!

GCS-S4786	10 Bolt* Chrome	15.99 ea.
GCS-S4787	12 Bolt Chrome	15.99 ea.
GCS-S5082	12 Bolt Polished	84.99 ea.
GCS-R0002X	Bolt Kit	8.99 kit

*8.5" Corporate 10 Bolt

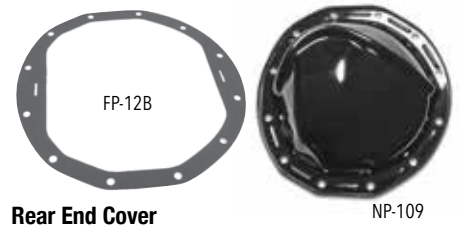

FP-12B

NP-109

Rear End Cover

OE style reproduction 12 bolt cover.

NP-109	All 12 Bolt Cover	49.95 ea.
FP-10B	10 Bolt Gasket	6.95 ea.
FP-12B	12 Bolt Gasket	6.95 ea.
BRE-2008	Cover Bolt	0.95 ea.



HBB-5847

FDP-5R

FPT-3

N-7081

Rear End Plugs & Posi Tag

OE style reproduction plugs and posi tag.

HBB-5847	All Metal Tag	6.95 ea.
FDP-5R	Plug 1"	16.95 ea.
FPT-3	Posi Tag 1"	12.95 ea.
FDP-3R	Plug 3/4"	16.95 ea.
FPT-1	Posi Tag 3/4"	12.95 ea.
N-7081	1967-72 Vent Plug	9.95 ea.



TTP-68

TTP-71

TTP-70

TTP-6972

Turbo HydraMatic Transmission ID Tags

Turbo HydraMatic transmission ID tag with rivet, measuring 1-1/8 inch x 1-15/16 inch. This installs on the side of the transmission case with the rivet. You must punch your own info onto the tag.

TTP-68	1968 Dark Olive	29.99 ea.
TTP-6972	1969 & 1972 Yellow	29.99 ea.
TTP-70	1970 Black	29.99 ea.
TTP-71	1971 Light Blue	29.99 ea.



FPF-49

FPF-668

Rear End Fluid

Original GM special fluid and posi additive.

FPF-668	Rear End Fluid	24.95 ea.
FPF-49	Posi Additive	14.95 ea.