



FG2001



FG2005



FG2031



FG2044



FG2003



FG2007



FG2042



FG2046

Fender Gripper

If you spend a lot of time working under the hood but don't want to scratch your paint a Fender Gripper is the answer! Made of non-slip material the Fender Gripper will not slide off slick surfaces.

- Soft and cushioned for protection
- Tools will not slip off fender cover
- Completely washable 22" X 34" standard size
- Strong PVC product reinforced with nylon mesh
- Impervious to motor oil, coolant, lacquer thinner, brake fluid, etc.
- Many favorite brand logos are available
- Will not harm your paint

FG2001	Bowtie	25.95 ea.
FG2003	Genuine Chevrolet	25.95 ea.
FG2005	Heartbeat of America	25.95 ea.
FG2007	Chevrolet Racing	25.95 ea.
FG2048	El Camino	25.95 ea.
FG2031	Chevelle	25.95 ea.
FG2042	General Motors	25.95 ea.
FG2044	SS	25.95 ea.
FG2046	Super Sport	25.95 ea.

ATE-3907



ACQ-1220N



Open Element Air Cleaner

Excellent reproduction of the original GM open element air cleaner assembly. Complete base with elbow assembly, chrome plated lid and AC Delco filter. Will fit most V8s with 4 bbl. carburetor.

ATE-3907	Complete Kit	84.99 kit
ACQ-1224	Chrome Lid Only	36.95 ea.
ACQ-1220N	Chrome Lid Only w/ Service Instructions	59.95 ea.
AAC-8864	Base Only w/ Elbow Assembly	54.95 ea.

ATW-3361



ATW-3359



1964-67 Closed Air Cleaner System

New complete closed air cleaner assemblies for your Nova, complete with base, lid and filter!

ATW-3359	1964-65 Complete Assembly	149.95 kit
ATW-3361	1966-67 Complete Assembly	145.95 kit

No Volume Discount.

GCS-S2194



GCS-S2194C



Retro Style Air Cleaner

This retro style hot rod air cleaner assembly is constructed of steel and is a great inexpensive custom touch to any street machine or sleeper. This filter kit includes a 3" paper air filter and the mounting stud with chrome wing nut.

GCS-S2194	All Black	168.99 kit
GCS-S2194C	All Chrome	198.99 kit



ACQ-1460

Dual Snorkel Air Cleaner Kit

OE style of the original factory closed element style dual snorkel air cleaner. Complete with original style base with correct elbow, lid and filter. Originally installed on 1970 Yenko Deuce but fits most 1968-74.

ACQ-1460	Complete Kit	184.99 ea.
ACQ-1461	Chrome Lid Only 17"	59.95 ea.
ACQ-1462	Satin Black Lid Only	49.99 ea.

No Volume Discount



ACC-3375

L-79 Dual Snorkel Air Cleaner

OE style reproduction of this hard to find chrome dual snorkel air cleaner which was installed on all L-79 (327 cubic inch 350 horsepower) Novas. Complete with base, filter and lid.

ACC-3375	1966-67 L79 Complete	289.95 kit
AL79-LIDN	1966-67 L79 Chrome Lid Only	179.95 ea.
ACC-3379	1966-67 L79 Base Only	189.95 ea.

No Volume Discount

K&N Air Filter Kits

K&Ns custom air cleaner assemblies are designed with the racer in mind. They incorporate good looks as well as the superior air flow that you expect from K&N. These custom air cleaner assemblies are designed for use with any engine that uses a round element air cleaner housing. They incorporate K&N Air Filters and provide more air flow than other assemblies of this type. Each complete assembly comes with base, element and top plate. Provides more air flow to the engine, designed to increase horsepower, washable and reusable air filters.



Chrome Lid Drop Base

KN-60-1280	1962-79 14X3", 1-1/4" Drop Base.....	95.99 ea.
KN-60-1290	1962-79 14X4", 1-1/4" Drop Base...	130.99 ea.
KN-60-1300	1962-79 14X5", 1-1/4" Drop Base....	125.99 ea.
KN-60-1310	1962-79 14X6", 1-1/4" Drop Base....	123.99 ea.
KN-60-1430	1962-79 14X3", 7/8" Drop Base.....	116.99 ea.
KN-60-1440	1962-79 14X4", 7/8" Drop Base.....	118.99 ea.
KN-60-1450	1962-79 14X5", 7/8" Drop Base.....	127.99 ea.
KN-60-1460	1962-79 14X6", 7/8" Drop Base.....	129.99 ea.

Chrome Lid Raised Base

KN-60-1263	1962-79 14X2" 5/16", 9/16" Raised Base.....	118.99 ea.
KN-60-1264	1962-79 14X3", 9/16" Raised Base.	104.99 ea.
KN-60-1260	1962-79 14X4", 9/16" Raised Base.	134.99 ea.
KN-60-1270	1962-79 14X4", 9/16" Raised Base.	145.99 ea.

X-Stream w/ Dropped Base

KN-66-3050	1962-79 14X3" 7/8" Drop Base.....	172.99 ea.
KN-66-3040	1962-79 14X3", 1-1/4" Drop Base....	131.99 ea.
KN-66-3060	1962-79 14X4", 1-1/4" Drop Base....	140.99 ea.
KN-66-3070	1962-79 14X5", 1-1/4" Drop Base...	187.99 ea.

X-Stream w/ Raised Base

KN-66-3000	1962-79 14X2 5/16", 9/16" Raised Base.....	174.99 ea.
KN-66-3010	1962-79 14X3", 9/16" Raised Base.	140.99 ea.
KN-66-3020	1962-79 14X4", 9/16" Raised Base.	187.99 ea.
KN-66-3030	1962-79 14X5", 9/16" Raised Base.	203.99 ea.

X-Stream Lid Only

KN-66-1401XB	1962-79 14" w/ Blue Trim Ring	89.99 ea.
KN-66-1401XP	1962-79 14" w/ Chrome Trim Ring...	80.99 ea.
KN-66-1401XR	1962-79 14" w/ Red Trim Ring.....	89.99 ea.
KN-66-1401	1962-79 14" w/ Black Trim Ring	72.99 ea.

Replacement Air Filter Only

KN-E3750	1962-79 14x4 Washable Filter	66.99 ea.
KN-E3760	1962-79 14x5 Washable Filter	75.99 ea.
KN-E3770	1962-79 14x6 Washable Filter	91.99 ea.

Recharger Care Kits

KN-99-5000	1962-79 w/ Aerosol Can.....	13.99 ea.
KN-99-5050	1962-79 w/ Squeeze Bottle	13.99 ea.

No Volume Discount.



Air Filter Exact Reproduction

Exact reproduction of the original style with "square mesh" design and original GM wording (silk screened) or AC Delco replacement style air filters.

N-1012	1967-69 Diagonal Mesh	32.95 ea.
N-1010	1970-72 Horizontal Mesh	32.95 ea.
ACW-212	All 14" AC Delco	11.99 ea.



Stainless Steel Air Cleaner

Highly polished stainless steel 14" air cleaner. Includes washable 3" filter.

GCS-S8005X	Drop Base	62.99 kit
------------	-----------------	-----------

Note: 5-1/8" carb opening. Includes mounting stud and chrome wing nut. Does not include gasket.



Ball Milled Flames Air Cleaner

Highly polished ball milled flames aluminum 14" air cleaner. Includes washable 3" filter.

GCS-S6915	Flat Base	94.99 kit
GCS-S6905X	Drop Base	104.99 kit

Note: 5-1/8" carb opening. Does not include stud, wing nut, or gasket.



Ball Milled Air Cleaner

Highly polished ball milled aluminum 14" air cleaner. Includes washable 3" filter.

GCS-S6815C	Drop Base	104.99 kit
------------	-----------------	------------

Note: 5-1/8" carb opening. Does not include stud, wing nut, or gasket.



Finned Aluminum Air Cleaner

Highly polished finned aluminum air cleaners. Includes washable 3" filter.

GCS-S6320	Flat Base 12" Oval.....	72.99 kit
GCS-S6723	Flat Base 14" Round	105.99 kit
GCS-S6725	Drop Base 14" Round	105.99 kit

Note: 5-1/8" carb opening. Includes mounting stud. Does not include wing nut or gasket.



Black Steel Air Cleaner Assembly

This black air cleaner assembly is constructed of steel and is a great inexpensive custom touch to any street machine or sleeper. Includes lid, filter, base and wing nut.

GCS-10095	Holley	29.95 kit
GCS-10099	Edelbrock.....	29.95 kit



ACQ-454-425

"Turbo Jet" Air Cleaner Lids

Our chrome 14" air cleaner lid (ACQ-1224) featuring high quality die cast "Turbo Jet" medallions.

ACQ-396	396.....	99.99 ea.
ACQ-454	454.....	99.99 ea.
ACQ-396-375	396, 375 Hp.....	155.00 ea.
ACQ-454-425	454, 425 Hp.....	155.00 ea.
ACQ-454-450	454, 450 Hp.....	149.95 ea.

Can be used with open element air cleaners or cowl induction.

APX-1400



ATE-5695



APJ-2153



ATE-5256

AP-315

APX-7700



Wing Nuts, Flame Arrestor & Studs

APX-1400	Chrome Wing Nut.....	5.99 ea.
APX-7700	Black Wing Nut.....	5.99 ea.
ATE-5695	Flame Arrestor.....	8.95 ea.

Carburetor Studs

APJ-2153	All w/ Holley Open Element.....	12.95 ea.
AP-315	All w/ Q-Jet.....	12.95 ea.
ATE-5256	Universal w/ Point End.....	8.95 ea.

AP-2B



Air Cleaner Gasket

Correct paper gasket for sealing air cleaner base to carburetor.

AP-2B	All 2 bbl.....	3.95 ea.
AP-4B	All 4 bbl.....	4.95 ea.



GAC-660

TCS Temp Sending Unit

Correct 2 prong sending unit mounts on right side cylinder head. This unit sends both low and high temperature signals to the TCS vacuum switch for correct operation.

GAC-660	1970 All.....	18.95 ea.
---------	---------------	-----------



ATCS-33R

TCS Littlefuse Relay

This is an exact reproduction of the correct Nova littlefuse TCS relay which was discontinued by GM in 1999. This authentic reproduction of the original transmission spark control relay vacuum advance delay features 4 prongs as original and replaces Delco number 3961573 exactly.

ATCS-33R	1970-72.....	54.95 ea.
----------	--------------	-----------



1114434

TCS Solenoid

Correct TCS solenoids which mount to the carburetor stud. Includes correct brackets.

1114432	1970-71 350/400.....	104.95 ea.
1114434	1970 BB.....	104.95 ea.



ATS-653

TCS Wire Retainer

Correct reproduction for Muncie.

ATS-653	1970-74 w/ Muncie.....	19.95 ea.
---------	------------------------	-----------



APR-4060



AX-301

Vacuum Advance Clips

Correct clip for retaining tube to intake manifold.

APR-4060	All V8.....	8.95 ea.
AX-301	1970 w/ TCS.....	13.95 ea.
CPN-100	Hose.....	1.95 pr. ft



Cowl Wiring Gutter

Correct plastic gutter used to hold engine harness against firewall.

AHT-2328	All.....	8.95 ea.
ABH-102	Correct Attaching Screws.....	0.95 pr.



APX-4946K

1970 TCS Vacuum Advance Kits

This one year only design utilized two steel tubes and a double clip.

APX-3944K	1970 BB Q-Jet TCS.....	29.99 kit
APX-4946K	1970 BB Holley TCS.....	29.99 kit



Vacuum Advance Kits

Our kits come complete with correct pre-bent tapered tube(s), correct white stripe vacuum hose and correct clip.

APX-3002	1964-69 SB 2bbl.....	20.99 kit
APX-3042	1964-69 SB 4bbl.....	20.99 kit
APX-2628	1964-71 SB Holley.....	20.99 kit
APX-3940	1968-69 BB Q-Jet.....	21.99 kit
APX-3946	1968-69 BB Holley.....	20.99 kit



GCS-S5973



GCS-S4973

Vacuum Advance Cover

This vacuum advance pod cover will give your distributor that show car look. Fits most GM distributors.

GCS-S4973	Chrome.....	3.99 ea.
GCS-S5973	Polished.....	16.95 ea.



ACK-1679

Choke Kits

Our kits come complete with thermal coil, cover, rod, retaining clip and screw.

ACK-1679	1967-69 SB Q-Jet.....	36.95 kit
ACK-8889	1966-69 BB Q-Jet.....	36.95 kit
ACK-1669	1968-69 BB Holley.....	36.95 kit
ACK-7072	1970-72 BB Q-Jet.....	36.95 kit
ACK-7071	1970-72 BB Holley.....	36.95 kit



AFP-4221

Carburetor Base Gaskets & Shields

Correct "stamped" gasket and stainless steel shield.

Gaskets

AFP-4221	1965-69 4 bbl. Q-Jet.....	6.95 ea.
AFP-4219	1970-72 4 bbl. Q-Jet.....	6.95 ea.
AFP-4222	1965-72 All Holley.....	6.95 ea.

Shield

ABB-7401	1965+ All Q-Jet.....	12.95 ea.
----------	----------------------	-----------



DEMON-1900



Demon Carburetors

WICKED POWER! The ALL NEW Street Demon® redefines the street carburetor with clean looks and ease of use! The Street Demon offers enthusiasts a straightforward carburetor designed to deliver a stable idle, amazingly crisp throttle response and smooth performance. Its optimized calibration and dual mounting pattern make it Run-Ready™ Designed for use on most stock to mildly modified V8s! These carbs feature vacuum secondaries and an electric choke.

625 CFM Carburetors

DEMON-1900	Silver w/ Aluminum Float Bowl ...	327.99 ea.
DEMON-1901	Silver w/ Composite Float Bowl ...	327.99 ea.
DEMON-1901BK	Black w/ Aluminum Float Bowl ...	394.99 ea.

750 CFM Carburetors

DEMON-1903	Silver w/ Aluminum Float Bowl ...	363.99 ea.
DEMON-1904	Silver w/ Composite Float Bowl ...	363.99 ea.

No volume discount.



HOL-0-1850SA



Holley Carburetors

Holley is one of the most trusted carburetors of all time! Its 600 CFM of airflow, vacuum secondaries, single fuel inlet and mechanical or electric choke makes it amazingly universal. The 4160 carbs are constructed from aluminum which compared to its zinc counterpart equates to a weight savings of 40%! Being aluminum also means it will hold its shine and can be hand polished for a custom look! Don't trust your performance to just anyone, Holley is the only modular carburetor company that has been in business for over 100 years and has powered every NASCAR champion since the 60's.

HOL-0-1850SA	All 4160 600 CFM Manual Choke.....	335.99 ea.
HOL-0-80457SA	All 4160 600 CFM Electric Choke.....	348.99 ea.
HOL-0-80670	All 4150 670 CFM Electric Choke.....	480.99 ea.

No volume discount.

Quick Fuel Technology Carburetors

"Innovators in fuel systems" is more than just a by-line. Quick Fuel Technology, since its inception in 1998, has grown exponentially in its 21 years of business culminating into the benchmark by which performance carburetors are measured.



QF-HR-600



QF-SS-650

The Hot Rod Series is a versatile performer designed for the most discerning street enthusiast. Featuring lightweight die-cast aluminum components, the HR-Series offer all the tunability you would expect from more expensive racing carburetors, including changeable bleeds, idle feed, power valve channel restrictions and four-corner idle. Offered in either vacuum or mechanical secondary models, all Hot Rod Series carburetors feature electric chokes and dual metering blocks for added performance. Now available in a 450 cfm model for applications with small displacement engines.

- All models feature a fully adjustable electric choke for easy starting
- Dual metering blocks w/ 4-corner idle for smooth and efficient idle quality
- Screw-in air bleeds and idle feed restrictions for quick unsurpassed tuning capability
- Dual inlet fuel bowls with sight glass windows for safe, easy float adjustment
- Universal throttle lever with sealed throttle shafts for smooth operation
- Tunable secondary opening rate
- Tumble polished for long lasting shine

4150 Carburetors Square Bore

QF-HR-600	600CFM Mechanical.....	501.99 ea.
QF-HR-650	650CFM Mechanical.....	501.99 ea.
QF-HR-750	750CFM Mechanical.....	554.99 ea.
QF-HR-850	850CFM Mechanical.....	589.99 ea.
QF-HR-680-VS	680CFM Vacuum.....	482.99 ea.
QF-HR-780-VS	780CFM Vacuum.....	499.99 ea.

No volume discount.



QF-SL-450-VS

Slayer Series street carburetors are designed with many of the same innovations and features that are built into all QFT™ race-winning carburetors, including changeable air bleeds and power valve channel restrictions. It's designed with a secondary metering plate with changeable jets and features all aluminum components for additional weight savings. All Slayer Series carburetors are equipped with universal throttle lever to accommodate a variety of models.

- Vacuum Secondaries • Electric Choke
- Single Metering Block • Secondary Metering Plate
- Cast Aluminum Throttle Body • Single Sight Glass Windows
- Changeable Air Bleeds • Adjustable Needles & Seats

4160 Carburetors Square Bore Dual Inlet

QF-SL-450-VS	450CFM Vacuum.....	347.99 ea.
QF-SL-600-VS	600CFM Vacuum.....	347.99 ea.
QF-SL-750-VS	750CFM Vacuum.....	377.99 ea.

4160 Carburetors Square Bore Single Inlet

QF-SL-1957E	600CFM Vacuum Silver.....	347.99 ea.
QF-BD-1957	600CFM Vacuum Black.....	422.99 ea.

No volume discount.

Super Street Series carburetors combine street-friendly drivability and track-capable performance in a single value-oriented package. Setting them apart from ordinary street carbs, they feature billet dual metering blocks and throttle-bodies that offer tighter tolerances and eliminate porosity. Not only are Super Street Series carbs available with both vacuum or mechanical secondaries, QFT™ also offers models designed and calibrated specifically for E85 fuel and blow-through forced induction applications. Running alternative fuel or boost no longer requires an expensive custom carburetor. All SS-Series carburetors are equipped with universal throttle levers to accommodate a variety of models. Bolting on the ultimate street/strip carburetor has never been easier.

- Red billet dual metering blocks & silver billet throttle bodies for improved durability
- Changeable idle, high-speed air bleeds & power valve restrictions
- Dual inlet fuel bowls with dual sight glass windows for easy float adjustment
- 4-Corner idle for precise idle and smooth transition
- Fully-adjustable electric choke with easy one wire hookup
- Race-ready with notched secondary floats and jet extensions
- Polished or Black Diamond™ finish available (some models)

4150 Carburetors Square Bore

QF-SS-650	650CFM Mechanical Silver.....	674.99 ea.
QF-SS-750	750CFM Mechanical Silver.....	674.99 ea.
QF-SS-850	850CFM Mechanical Silver.....	674.99 ea.
QF-BD-750	750CFM Mechanical Black.....	725.99 ea.
QF-SS-680-VS	680CFM Vacuum Silver.....	627.99 ea.
QF-SS-780-VS	780CFM Vacuum Silver.....	627.99 ea.

No volume discount.



QF-SQ-650

Street-Q carburetor is intended to deliver legendary Q-Series performance to hardcore street enthusiasts at a reduced price. The major differences between the Street-Q and the race-bred Q-Series is the substitution of cast metering blocks and a cast throttle body in place of fully-machined billet components. All of the critical functionality is retained - 2-circuit metering, downleg boosters, changeable idle and high-speed air bleeds and 4-corner idle. A universal throttle lever to accommodate a variety of models.

- Lightweight die-cast aluminum components
- Changeable idle and high-speed air bleeds
- 2-circuit metering - 4-Corner idle system
- Downleg boosters
- 700-R4 mounting holes

4150 Carburetors Square Bore

QF-SQ-650	650CFM Mechanical Silver.....	537.99 ea.
QF-SQ-750	750CFM Mechanical Silver.....	578.99 ea.
QF-SQ-850	850CFM Mechanical Silver.....	594.99 ea.
QF-SQ-950	950CFM Mechanical Silver.....	607.99 ea.

No volume discount.



QF-Q-750

Q-Series Race carburetors are purpose-built for the dragstrip. To combat the g's experienced during hard launches, Q-Series carbs are equipped with notched floats and secondary jet extensions. The high-flow aluminum main body isn't just lightweight, but it also features recessed air bleed cavities for improved air flow. Die-cast venturi are machined to exacting tolerances for outstanding throttle response. Billet metering blocks ensure a uniform fuel curve, while throttle-bodies enhance durability. For those days when track conditions vary from one pass to the next, QFT's QuickLink system makes adjusting the secondaries easy on models equipped with mechanical secondaries. The Q-Series is our most comprehensive line of carburetors, with applications available for use with gasoline, methanol and E85 fuels, forced induction, drag race, circle track and comes in both vacuum and mechanical secondary models.

- Lightweight aluminum main body
- Mechanical secondary
- Aluminum fuel bowls with dual sight glass windows
- Billet metering blocks with 4-corner idle system
- Changeable idle feed and power valve channel restrictions
- PTFE coated and sealed shafts that have been slabbed for added air flow
- Red anodized billet metering blocks and throttle plate

4150 Carburetors Square Bore

QF-Q-750	750CFM Mechanical Silver/Red.....	780.99 ea.
QF-Q-750-B2	750CFM Mechanical Silver/Red*.....	836.99 ea.
QF-Q-850	850CFM Mechanical Silver/Red.....	836.99 ea.
QF-Q-950	950CFM Mechanical Silver/Red.....	891.99 ea.
QF-BDQ-750	750CFM Mechanical Black/Black.....	836.99 ea.

*Draw thru supercharger applications with 2 carbs.
No volume discount.



QF-FX-4710

QFX-Series stands as the flagship model in QFT's lineup. Raised air horns improve entry angle into the venturi while ensuring undisrupted flow over the air bleeds. Annular boosters with CNC-machined billet aluminum inserts provide increased air flow, a stronger signal and less turbulence. QFX carbs offer unparalleled fuel atomization with annular boosters specific for either gas, methanol, or E85 fuels. Five-emulsion billet metering blocks and four-corner idle circuits offer flexible tunability that today's high-horsepower engines demand. Ready to run out of the box, the QFX-Series carburetor will help you get to the winner's circle.

- QFX aluminum main body w/raised venturi
- Billet aluminum metering blocks with screw in restrictions
- Aluminum fuel bowls with dual sight windows and fuel inlets
- Viton .130" Needles and Seats
- Billet Aluminum annular booster inserts
- QuickLink™ adjustable secondary opening adjustment
- Hand assembled and engine tested

4500 Spread Bore Dominator Style

QF-FX-4710	1150CFM Mechanical Black/Black.....	1131.99 ea.
------------	-------------------------------------	-------------

No volume discount.



BTE-1475

BMG-0095

Carb Attaching Kits

Correct OEM bolt kit for attaching carburetor to intake manifold.

BMG-0095	All w/Holley	7.99 ea.
BTE-1475	All w/Q-Jet	8.95 ea.



AHL-516

Carburetor Inlet Nuts

Correct Holley carb fuel inlet nuts & washers.

AHL-516	5/16" (Stock GM)	12.99 ea.
AHL-38	3/8"	12.99 ea.



AS-761



AS-166



ACS-0069



ATE-0068



ACS-7454

Carb Return Springs

New correct color coded springs.

AS-761	Most 4bbl Black	9.95 ea.
AS-166	1967-68 Holley Green.....	8.95 ea.
ACS-0069	1969 Holley Green	8.95 ea.
ATE-0068	1968-72 Q Jet Black	8.95 ea.
ACS-7454	1970-72 Holley Blue	9.95 ea.



MS142-08B



MS142-08R

Eddie Motorsports Billet Throttle Cable Brackets

These Eddie Motorsports billet GM throttle cable brackets mount to the base of Holley carburetors. The kit includes the cable mount bracket, return springs and bracket and installation hardware.

With 4150/4160 Series Carburetor

MS142-08B	1967-87 Blue	77.99 kit
MS142-08R	1967-87 Red	77.99 kit
MS142-08BA	1967-87 Black Anodized	77.99 kit
MS142-08CA	1967-87 Clear Anodized	77.99 kit

With 4500 Series Carburetor

MS142-09B	1967-87 Blue	102.99 kit
MS142-09R	1967-87 Red	102.99 kit
MS142-09BA	1967-87 Black Anodized	102.99 kit
MS142-09CA	1967-87 Clear Anodized	102.99 kit

No Volume Discount.



Chrome Universal Carburetor Throttle Return Kit

Designed to make mounting the spring a snap! Works on most carburetors.

GCS-S2291	Universal.....	5.99 kit
-----------	----------------	----------

Note: Due to the universal nature of this part, fitting and/or modifications may be required.

GCS-S2291

GCS-S2083



Chrome Holley Carburetor Throttle Return Kit

Designed to make mounting the spring a snap! Works on most Holley carburetor applications.

GCS-S2083	Holley	14.99 kit
-----------	--------------	-----------

Note: Due to the universal nature of this part, fitting and/or modifications may be required.

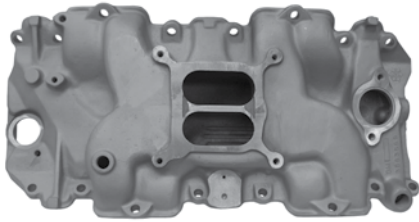

Intake Manifold 3885069
OE style SHP big block manifolds.

- 3885069 1968 396 L78, L79, 427 L88.....399.95 ea.
 - 3933198 1968-69 396, 427 SHP L88 ZL-1.....399.95 ea.
 - 3933163 1968-69 396/375 L78 L89.....399.95 ea.
 - 3963569 1970 Low Rise 396/375 L78 L89.... 399.95 ea.
 - ABB-3569C 1970 LS6, L78, L89 Splash Shield.....39.95 ea.
- Ships Oversize 2 in a special box.*



WND-8120WND

Weiand Street Warrior Intake Manifolds

The Weiand Street Warrior is designed for use on stock or stroker combinations that feature efficient cylinder heads. The latest advances in cam design necessitated the design of a new intake manifold and the Weiand Street Warrior manifolds fill that void.

Square Bore Carburetors

- WND-8120WND Small Block w/ 55-86 Heads 169.99 ea.
- WND-8121 Small Block w/ Vortec Heads 212.99 ea.

Spread Bore Carburetors

- WND-8126 Small Block w/ 87-95 Heads 212.99 ea.
- No volume discount.*



WND-8150

Weiand Speed Warrior Intake Manifolds

The Weiand Speed Warrior features long, separated runners for bottom-end and mid-range power, plus a special runner design and larger plenum to flow the air needed for high-rpm horsepower. All of this usable power makes this intake perfect for your street and strip hot rod!

- WND-8150 Small Block w/ 55-86 Heads 181.99 ea.
 - WND-8170WND Small Block w/ 87-95 Heads 192.99 ea.
- No volume discount.*



BPI-9140

Intake Manifold Bolts OEM

Our OEM intake bolts feature correct size, coloring and head markings.

- BPI-4400 All SB "M" Flanged (12p)..... 16.95 kit
- BPI-9140 All BB "M" Cast Intake (16p)..... 21.95 kit
- BPI-2271 All BB "A" Aluminum Intake (16p)..... 27.99 kit



APN-0138

APN-0238

APN-0038

APN-638

APN-738

APN-838

Intake Manifold Vacuum Fittings

These high quality fittings for rear of intake manifold have correct "slip-on" and threaded ends. These fittings have a variety of uses: power brake hose, auto transmission, air conditioning, cruise control, etc. Guaranteed to look, fit and function exactly as original.

- APN-0138 (1) Slip-On Fitting 17.99 ea.
- APN-0238 (2) Slip-On Fittings..... 15.99 ea.
- APN-0038 (1) Threaded Port 15.99 ea.
- APN-638 (1) Threaded (1) Slip-On 20.99 ea.
- APN-738 (1) Threaded (2) Slip-On 23.99 ea.
- APN-838 (1) Threaded (3) Slip-On 29.95 ea.

BPS-3679



Intake Studs

Correct intake manifold studs for various uses: alternator, solenoid and power brake tube. Includes correct nut.

- BPS-3679 All 3/8" x 3/8" (Zinc)..... 7.99 ea.
(p.s. bracket, alternator mount, etc.)
- BPS-7432 All 5/16" x 3/8" (Black) 3.95 ea.
(TCS, P.B. tube, etc.)



N-1252

Oil Filler Tube

Chrome intake oil filler tube used with screw-in PCV filter.

- N-2258 1966-67 283 / 327 Black.....36.95 ea.
- N-1252 1966-67 L89.....42.95 ea.



AOC-1254

AOC-1689

Oil Filler Tube Cap

Correct chrome twist-on cap with "S" rivet.

- AOC-1689 1966-67 283 / 327 Black.....11.95 ea.
- AOC-1254 1966-67 L89.....17.95 ea.



APX-1115



APX-1015

Engine Block Lifting Ring

These correct steel stamped lifting rings were installed at the engine plant for ease of installation.

- APX-1015 Most SB.....25.99 set
- APX-1115 All BB25.99 set
- BPX-230 Lifting Ring Bolt.....0.95 ea.



GCS-S9619

GCS-S9620

Chrome Throttle Cable Brackets

Designed to work with your GM throttle cable on most carburetor applications. Available with or without kickdown provision.

- GCS-S9619 Without Kickdown 9.99 kit
 - GCS-S9620 With Kickdown..... 9.99 kit
- Note: Due to the universal nature of this part fitting and/or modifications may be required.*



Throttle Linkage To Cable Conversion Kit

Remove the old sticky linkage and upgrade to a smooth operating throttle cable set up. This kit includes the accelerator pedal assembly, accelerator cable, cable bracket and cable retaining clip.

APA-6CBH	1968-74 Holley	105.64 kit
APA-6CBQJ	1968-74 Q-Jet	108.04 kit

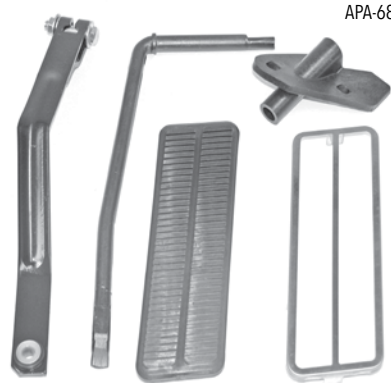

Accelerator Pedal Linkage Kit

New assemblies complete from the pedal to the arm and includes the pedal trim.

APA-68	1968-72 All V8	57.95 kit
--------	----------------------	-----------



Accelerator Rod Kits

For those using rods, our kits come complete with pre-bent rod, swivel, grommet, sleeve and hardware.

AR-4320	1963-67 All*	16.95 kit
NA-103	1968-72 SB 4bbl	30.99 kit
APJ-1302	1968 Holley SB	29.99 kit
APJ-1369	1968-74 BB Holley	29.99 kit

* May require slight modification.



Accelerator Rod Grommet Kit

APJ-1314	1962-72 Most	7.95 kit
----------	--------------------	----------



Accelerator Arm & Rod

Correct throttle arm and rod for attaching it to the accelerator pedal.

AMD-1600	1962-67 Arm	59.95 ea.
A-9801	1968-72 Thru-Rod	26.99 ea.
ADR-476	1968-72 Arm	19.99 ea.



Accelerator Rod Support

Correct support bracket used to hold rod in place. Complete with screws.

AY-12	1968-72 (plastic)	16.99 ea.
-------	-------------------------	-----------



Accelerator Brackets

Your choice of brackets with GM numbers or without GM numbers. Both fit as original.

3992376	w/ Q-Jet GM #'s	32.95 ea.
3972619	w/ Holley GM #'s	32.95 ea.
AXK-68	w/ Q-Jet No #'s	22.95 ea.
ADT-0014	w/ Holley No #'s	19.95 ea.

BUY 'N SAVE WITH KITS

CPX-9038



PCV Hose & Filter Kit

Our kits come complete with correct hose, AC Delco filter and correct black pinch clamp. Pieces also available separately.

CPX-9038	All Complete	16.82 kit
CPH-9038	Hose Only	11.95 ea.
CTC-1132	Pinch Clamp Only	0.50 ea.
CAC-3800	PCV Filter Only	5.95 ea.

CE CE CE CE CE CE



ATH-99

Accelerator Cables

New GM service replacement cables with casings and bushings as original.

ATH-99	1968-74 V8 4bbl	34.95 ea.
AZC-88	Cable Clip	6.95 ea.
AXJ-CE	Cable Decal	4.95 ea.
ATH-99-BOLT	Cable to Firewall Bolt	0.25 ea.

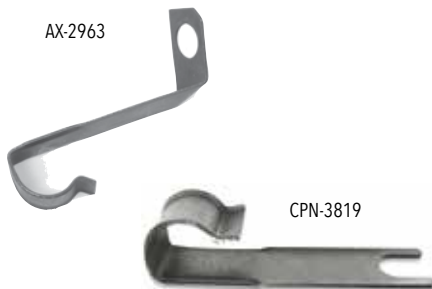

PCV Retaining Hose Clip

Exact reproduction of original PCV hose retaining clip, with correct bends and black phosphate coating.

CPN-3819	1967-72 SB Holley	16.99 ea.
CPN-3819	1966-67 L-79	16.99 ea.
AX-2963	1968-69 BB Q-Jet	13.95 ea.



ATH-3369KIT-H

Accelerator Cable & Bracket Kit - All BB/SB with SHP Holley







This new accelerator cable and bracket kit is the perfect solution for smooth operation when your originals are either worn or missing. This kit includes a reproduction accelerator cable, bracket and retaining clip.





ATH-3369KIT-H	1968-74 All	41.27 kit
---------------	-------------------	-----------

No Volume Discount.

Air Conditioning Brackets Big Block

OE style reproduction brackets for installing original Delco air conditioning compressors in all 1969-72 Novas with big blocks using long water pumps.

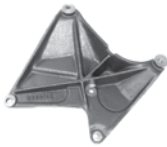
- ZAC-A1

ZAC-A1 1969-70 Rear Compressor Bracket..... 44.95 ea.
- ZAC-A2

ZAC-A2 1969-70 Front Bracket (on head)..... 69.95 ea.
- ZAC-A3

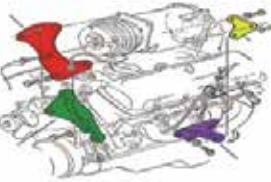
ZAC-A3 1969-70 Front Compressor Bracket..... 44.95 ea.
- ZAC-A4

ZAC-A4 1969-70 Rear Compressor Plate..... 24.95 ea.
- ZAC-A5

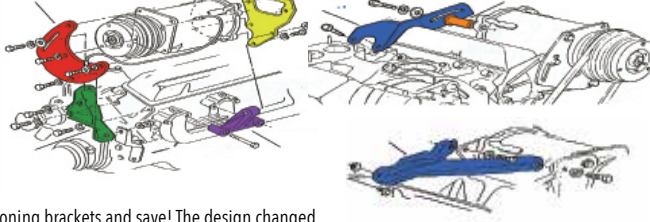
ZAC-A5 1969-71 Lower Bracket (to head) 46.95 ea.
- ZAC-A6

ZAC-A6 1969-70 Rear Compressor Spacer..... 21.95 ea.

- ZAC-B1

ZAC-B1 1970+ Compressor to Intake Bracket ... 26.95 ea.
- ZAC-B5

ZAC-B5 1972+ Lower Bracket (to head)..... 44.95 ea.
- ZAC-B2

ZAC-B2 1970+ Front Bracket (on head)..... 69.95 ea.
- ZAC-B3

ZAC-B3 1970+ Front Compressor Bracket 42.95 ea.
- ZAC-B4

ZAC-B4 1970+ Rear Compressor Plate..... 44.95 ea.

Early Design



Late Design



Buy a complete set of big block air conditioning brackets and save! The design changed midway through 1970, so be sure to check your original brackets for early style (ZAC-AKIT) or late style (ZAC-BKIT).

ZAC-AKIT	1969-70 BB	228.33 kit
ZAC-BKIT	1970-71 BB	208.58 kit
ZAC-BKIT2	1972 BB.....	206.78 kit

BUY'N SAVE
WITH KITS

AC On Engine Hardware Kits

- 68AA-SB 1968 SB..... 29.99 kit
- 68AA-SSB 1968 SB w/ Smog..... 32.99 kit
- 69AA-SB 1969 SB..... 52.99 kit
- 70AA-SB 1970 SB..... 42.99 kit
- 70AA-BB 1970 BB..... 41.99 kit
- 71AA-SB 1971 SB..... 40.99 kit
- 72AA-SB 1972 SB..... 43.99 kit

AC Box Under Hood On Firewall Hardware Kits

- 68NA-F 1968 SB..... 42.95 kit
- 69NA-F 1969 SB..... 64.99 kit
- 70NA-F 1970 SB..... 56.99 kit
- 71NA-F 1971 SB..... 53.99 kit
- 72NA-F 1971 SB..... 49.99 kit



AC Delco Water Pumps

Brand new AC Delco water pumps.

- ABR-0898 1962-68 SB (Short Style)..... 63.95 ea.
- ABR-0918 1968 BB (Short Style)..... 119.99 ea.
- ABR-1109 1969-74 SB (Long Style) 65.95 ea.
- ABR-1002 1969-74 BB (Long Style)..... 89.99 ea.



Water Pump OEM Attaching Bolt Kits

Correct style attaching bolts with "TR" head markings.

- ATR-3232 1964-68 3 Bolts 1 Stud..... 9.99 kit
- ATR-4334 1969-72 All 4 Bolts M Mark..... 11.99 kit
- AWS-301S Stud Only (Short) 2.99 ea.
- AWS-302L Stud Only (Long)..... 3.95 ea.



Water Pump Bypass Hose Kits

Correct OEM GM marked bypass hose with correct clamps.

- CPH-1637 1966-67 SB L-79 12.95 kit
- CPH-1658 1968 BB (Molded)..... 12.95 kit
- CPH-1672 1969-74 BB (Ribbed)..... 9.95 kit
- CPB-234 1962-67 SB Clamp (NOS)..... 3.95 ea.
- CPB-034 1965-72 BB Clamp (NOS)..... 4.95 ea.



Water Pump Pulley

OE style or original water pump pulleys.

- AWP-796 1969+ All V8 (1 Groove) 29.95 ea.
- AWP-9950 1968 All BB (1 Groove)..... 42.95 ea.
- AWP-656 1968 BB (2 Groove Deep)..... 99.95 ea.
- AWP-1394 1969+ BB (1 Groove Deep)..... 47.99 ea.
- AWP-949 1969+ All (2 Groove w/ AC)..... 99.99 ea.

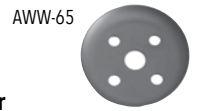

Short Water Pump Washer

This washer is for any Chevrolet engine with a short water pump. Since this part can't be seen when the pulley is installed, most people are unaware it exists, but it provides important support for the pulley.

- AWW-65 1962-68 ALL..... 5.99 ea.





TUF-1354NA



Tuff Stuff Water Pumps

Tuff Stuff water pumps are available in multiple different finishes. Available in standard flow or high flow (Super Flow) version for high power applications. Also available in "Smoothie" version, which features flat top casting with no top water port or plug.

Small Block

TUF-1354NA	1962-68 Short, Chrome	109.99 ea.
TUF-1354N	1962-68 Short, SC, Cast Finish	76.99 ea.
TUF-1354NC	1962-68 Short, SC, Black.....	88.99 ea.
TUF-1354NB	1962-68 Short, SC, Chrome	117.99 ea.
TUF-1354NAS	1962-68 Short, Smoothie, Chrome.....	115.99 ea.
TUF-1449NA	1969-79 Long, Chrome	139.99 ea.
TUF-1511NC	1969-79 Long, S, Plat, Cast Finish	158.99 ea.
TUF-1449N	1969-79 Long, SC, Cast Finish	76.99 ea.
TUF-1449NC	1969-79 Long, SC, Black	88.99 ea.
TUF-1449NB	1969-79 Long, SC, Chrome	156.99 ea.
TUF-1448NC	1969-79 Long, SC, Smooth, Cast.....	121.99 ea.
TUF-1448NB	1969-79 Long, SC, Smooth, Pol Alum	156.99 ea.

Big Block

TUF-1494N	1962-68 Short, Cast Finish	82.99 ea.
TUF-1494NC	1962-68 Short, SC, Black	105.99 ea.
TUF-1494NA	1962-68 Short, SC, Chrome	139.99 ea.
TUF-1461NA	1969-79 Long, S, Chrome	164.99 ea.
TUF-1461N	1969-79 Long, SC, Cast Finish	93.99 ea.
TUF-1461NC	1969-79 Long, SC, Black	112.99 ea.
TUF-1496NA7	1964-68 Short, Smooth Blk Chrome	251.99 ea.
TUF-1495NA7	1964-68 Short, SC, Smooth Blk Chrome	325.99 ea.
TUF-1459NA7	1969-77 Long Smooth Blk Chrome	229.99 ea.
TUF-1448NA7	1969-77 Long, SC, Smooth Blk Chrome	194.99 ea.

No volume discount.

Tuff Stuff Water Pump Bolt Kits

Chrome plated hex head bolts. Includes 4 bolts, 4 flat washers and 4 lock washers.

TUF-7675A	All SB, Short Style	18.99 ea.
TUF-7676A	All BB, Short Style	18.99 ea.
TUF-7678A	All BB, Long Style.....	18.99 ea.



AWN-058



APN-1060



AWN-1059

Heater Hose / Bypass Nipples

OE style reproduction zinc plated fitting.

AWN-058	5/8" Short	7.95 ea.
AWN-034	3/4" Short	7.95 ea.
AWN-134	3/4" Long w/ A-C	8.95 ea.
APN-1060	3/4" Bypass Slotted	7.95 ea.
AWN-1059	1966-67 L-79 SHP 90°	22.95 ea.



GCS-S9478

Billet Water Pump Pulleys

These show quality billet aluminum water pump pulleys will set your show car apart from the crowd. Made of high quality aircraft aluminum.

GCS-S9478	SB, SWP, 1 Groove, Satin	38.99 ea.
GCS-S9478POL	SB, SWP, 1 Groove, Polished	41.99 ea.
GCS-S9600	SB, SWP, 1 Groove, Chrome	20.99 ea.
GCS-S9479	SB, SWP, 2 Groove, Satin	52.99 ea.
GCS-S9479POL	SB, SWP, 2 Groove, Polished	52.99 ea.
GCS-S9601	SB, SWP, 2 Groove, Chrome	20.99 ea.
GCS-S9482	SB, LWP, 1 Groove, Satin.....	35.99 ea.
GCS-S9482POL	SB, LWP, 1 Groove, Polished.....	41.99 ea.
GCS-S9604	SB, LWP, 1 Groove, Chrome	20.99 ea.
GCS-S9483	SB, LWP, 2 Groove, Satin.....	52.99 ea.
GCS-S9483POL	SB, LWP, 2 Groove, Polished.....	62.99 ea.
GCS-S9605	SB, LWP, 2 Groove, Chrome	20.99 ea.
GCS-S8840	BB, SWP, 1 Groove, Satin	41.99 ea.
GCS-S8840POL	BB, SWP, 1 Groove, Polished	41.99 ea.
GCS-S8842	BB, SWP, 2 Groove, Satin	52.99 ea.
GCS-S8842POL	BB, SWP, 2 Groove, Polished	57.99 ea.
GCS-S9815	BB, SWP, 2 Groove, Chrome	31.99 ea.
GCS-S8844	BB, LWP, 2 Groove, Satin	52.99 ea.
GCS-S8844POL	BB, LWP, 2 Groove, Polished.....	41.99 ea.
GCS-S9723	BB, LWP, 2 Groove, Chrome.....	25.99 ea.

Note: SWP = Short Water Pump. LWP = Long Water Pump.

TUF-4450A



Tuff Stuff Chrome Heater Hose/Bypass Nipples

Chrome plated heater hose/bypass hose fittings.

TUF-4450A	3/4" Long	10.99 ea.
TUF-4450B	3/4" Short.....	10.99 ea.
TUF-4450C	5/8" Short.....	10.99 ea.

ABR-7660

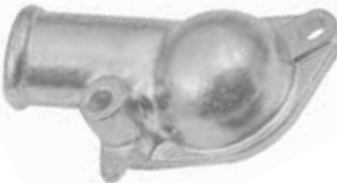

Cast Iron Thermostat Housing

Correct thermostat housing for cast iron manifolds. This was the most common housing and was found on most V8s.

ABR-7660	Most V8.....	14.95 ea.
----------	--------------	-----------

ACI-7660



Aluminum Thermostat Housing

Correct thermostat housing for high performance engines with aluminum intake manifolds. GM #3877660.

ACI-7660	Aluminum	45.99 ea.
----------	----------------	-----------

ATE-7396



L-79 Thermostat Housing

This is the correct gooseneck style thermostat housing for your L-79 engine.

ATE-7396	1966-67 L-79	59.95 ea.
----------	--------------------	-----------

GCS-S9229



Chrome Thermostat Housing

Chrome steel thermostat housing with o-ring and bolts. Water neck points toward the driver side of the radiator.

GCS-S9229	Most V8.....	12.99 kit
-----------	--------------	-----------



ACT-180

Thermostat

Original AC-Delco thermostat.

ACT-180	180-85 Degrees.....	6.95 ea.
ACT-190	190-95 Degrees.....	6.95 ea.



TUF-900160



Tuff Stuff Performance Thermostats

These stainless steel thermostats flow up to 56 gallons per minute, ordinary thermostats flow 37 gallons per minute. The 50 percent increased coolant flow reduces the delay in engine warm-up times, allowing trapped air in the cooling system to escape and stabilize the pressure of the cooling system. Ideal for high performance muscle cars, street rods and customs.

TUF-900160	160 Degree	17.99 ea.
TUF-900180	180 Degree	17.99 ea.
TUF-900195	195 Degree	17.99 ea.

No volume discount.



GCS-S8702

Billet Engine Pulley Kit

All of the common dress up items in one easy kit! Includes water pump pulley, crank pulley, alternator pulley, power steering pulley and billet aluminum bracket kit.

GCS-S8702	SB, SWP, 1 Groove	293.99 kit
GCS-S8703	SB, LWP, 1 Groove	262.99 kit
GCS-S8704	SB, SWP, 2 Groove	314.99 kit
GCS-S8705	SB, LWP, 2 Groove	304.99 kit
GCS-S8706	BB, SWP, 1 Groove.....	304.99 kit
GCS-S8707	BB, SWP, 2 Groove.....	314.99 kit



GCS-S9480

Billet Crank Pulleys

These show quality billet aluminum crank pulleys will set your show car apart from the crowd. Made of high quality aircraft aluminum.

GCS-S9480	SB, SWP, 1 Groove, Satin	31.99 ea.
GCS-S9480POL	SB, SWP, 1 Groove, Polished	41.99 ea.
GCS-S9602	SB, SWP, 1 Groove, Chrome	22.99 ea.
GCS-S9481	SB, SWP, 2 Groove, Satin	41.99 ea.
GCS-S9481POL	SB, SWP, 2 Groove, Polished	41.99 ea.
GCS-S9603	SB, SWP, 2 Groove, Chrome	20.99 ea.
GCS-S8858	SB, SWP, 3 Groove, Satin	57.99 ea.
GCS-S8858POL	SB, SWP, 3 Groove, Polished	52.99 ea.
GCS-S8963	SB, SWP, 3 Groove, Chrome	38.99 ea.
GCS-S9484	SB, LWP, 1 Groove, Satin.....	52.99 ea.
GCS-S9484POL	SB, LWP, 1 Groove, Polished.....	52.99 ea.
GCS-S9606	SB, LWP, 1 Groove, Chrome.....	36.99 ea.
GCS-S9485	SB, LWP, 2 Groove, Satin.....	41.99 ea.
GCS-S9485POL	SB, LWP, 2 Groove, Polished.....	52.99 ea.
GCS-S9607	SB, LWP, 2 Groove, Chrome.....	36.99 ea.
GCS-S9486	SB, LWP, 3 Groove, Satin.....	52.99 ea.
GCS-S9486POL	SB, LWP, 3 Groove, Polished.....	55.99 ea.
GCS-S9608	SB, LWP, 3 Groove, Chrome.....	40.99 ea.
GCS-S8841	BB, SWP, 1 Groove, Satin.....	34.99 ea.
GCS-S8841POL	BB, SWP, 1 Groove, Polished.....	41.99 ea.
GCS-S9817	BB, SWP, 1 Groove, Chrome.....	28.99 ea.
GCS-S8843	BB, SWP, 2 Groove, Satin.....	41.99 ea.
GCS-S8843POL	BB, SWP, 2 Groove, Polished.....	52.99 ea.
GCS-S9816	BB, SWP, 2 Groove, Chrome.....	30.99 ea.
GCS-S8849	BB, SWP, 3 Groove, Satin.....	57.99 ea.
GCS-S8849POL	BB, SWP, 3 Groove, Polished.....	57.99 ea.
GCS-S8845	BB, LWP, 3 Groove, Satin.....	73.99 ea.
GCS-S8845POL	BB, LWP, 3 Groove, Polished.....	73.99 ea.
GCS-S9724	BB, LWP, 3 Groove, Chrome.....	36.99 ea.

Note: SWP = Short Water Pump. LWP = Long Water Pump.



ACP-904



NQ-457



ACP-203



ACP-108



AHQ-1396



ACP-330

Crank Pulleys

All pulleys are original GM or the highest quality reproductions on the market. Each pulley is finished in factory matte black like the originals.

ACP-904	1964-67 327/350 1 Groove	39.95 ea.
ACP-833	1966-67 2 Groove Deep	52.95 ea.
ACP-414	1969-72 SB 3 Groove	69.99 ea.
NQ-457	1969-72 350 2 Groove Deep.....	79.99 ea.
ACP-203	1964-68 396 1 Groove.....	45.95 ea.
ACP-108	1965-68 396/375 2 Groove Deep**.....	55.95 ea.
ACP-333	1965-68 396/375 3 Groove Deep Cast.....	199.95 ea.
AHQ-1396	1969-72 396 2 Groove Deep.....	89.99 ea.
ACP-330	1969-72 396/454 3 Groove w/ A/C.....	74.95 ea.
ACP-404	1969-72 SB 2 Groove	69.95 ea.

**for all with power steering use with ADP-61



BPB-5934



ABB-5790

Harmonic Balancer Attaching Bolt-Washer

BPB-5933	1964-72 Most SB	15.99 kit
BPB-5934	1965-72 All BB.....	14.99 kit

Alternator Pulleys

ABB-5799	Standard (2-3/4" OD).....	20.99 ea.
ABB-5790	All w/ SHP (3-1/4" OD) Deep.....	39.95 ea.
ABN-105	Correct Retaining Nut	3.99 ea.



Tuff Stuff Hot Start Remote Solenoid Kit

Give your starter an extra 12V boost with these hot start kits from Tuff Stuff! This kit is designed to eliminate hot start problems that are common with starter-mounted solenoids. Ideal for GM full-size OEM starters.

TUF-7629	1964-77 All	23.99 kit
----------	-------------------	-----------

No volume discount.

NO CORE CHARGE

AIT-6961



Alternators

Rebuilt alternator made in the USA. Each alternator is 100% tested and rebuilt to exceed OEM specs.

- AIT-6961 41 Amp External Reg 79.95 ea.
- AIT-6963 55 Amp External Reg 89.95 ea.
- AIT-3342 63 Amp Internal Reg 84.99 ea.

No Volume Discount.



TUF-7102



Tuff Stuff Externally Regulated Alternators

All Tuff Stuff alternators are hand built in Cleveland, Ohio and are tested to meet or exceed OEM specifications. All Tuff Stuff alternators are made from 100% new components and carry a one year limited warranty. All alternators are for 12 volt, negative ground systems, except where noted.

- TUF-7102 80 Amp Cast Aluminum V-Belt 92.99 ea.
- TUF-7102NA 80 Amp Chrome V-Belt 127.99 ea.
- TUF-7102NAP 80 Amp Pol Aluminum V-Belt 127.99 ea.
- TUF-7102NF 80 Amp Black V-Belt 122.99 ea.
- TUF-7102NC 100 Amp Chrome V-Belt 127.99 ea.
- TUF-7102NCP 100 Amp Pol Aluminum V-Belt 127.99 ea.
- TUF-7102NE 100 Amp Black V-Belt 122.99 ea.
- TUF-7102NFBW 100 Amp Black Wrinkle V-Belt 126.99 ea.
- TUF-7102NKBW 140 Amp Black Wrinkle V-Belt 152.99 ea.



TUF-7520B

Tuff Stuff Alternator Pigtails

Replace worn or broken alternator connectors with Tuff Stuff's replacement pigtails to eliminate any electrical issues. These will fit factory alternators.

- TUF-7520B Externally Regulated 10DN 10.99 ea.
- TUF-7520A Internally Regulated 10SI 7.99 ea.
- TUF-7520C Internally Regulated CS130,CS144. 10.99 ea.



APX-1724

APX-2559

AVC-1144

Alternator Accessories

- APX-1724 All Fan/Nut 15.95 kit
- AVC-1144 1962-74 All Pigtail External 4.95 ea.
- APX-2559 Rear Alternator Boot 4.95 ea.



TUF-7127ND



Tuff Stuff Internally Regulated Alternators

Designed to handle the demand for power needed for today's electronics, Tuff Stuff's high powered internally regulated alternators are perfect if you have added a set of high powered headlights, or a high powered stereo system, or any other electronic systems to your Nova. Although meant for 1971 and newer internally regulated set ups, they can be used on older models that have been converted from external to internally regulated.

- TUF-7127NB 80 Amp, 1 Wire, Chrome 126.99 ea.
- TUF-7127D 100 Amp, 1 Wire, Cast Finish 92.99 ea.
- TUF-7127NF 100 Amp, 1 Wire, Black 126.99 ea.
- TUF-7127ND 100 Amp, 1 Wire, Chrome 126.99 ea.
- TUF-7127NDP 100 Amp, 1 Wire, Polished Aluminum 126.99 ea.
- TUF-7127K 140 Amp, 1 Wire, Cast Finish 131.99 ea.
- TUF-7127NK 140 Amp, 1 Wire, Chrome 145.99 ea.
- TUF-7139ABULL 100 Amp, Silver Bullet, 1 Wire, Chrome 163.99 ea.
- TUF-7140FBULL 140 Amp, Silver Bullet, 1 Wire, Black 180.99 ea.
- TUF-7140ABULL 140 Amp, Silver Bullet, 1 Wire, Chrome 219.99 ea.
- TUF-7127ND7 100 Amp 1 Wire Blk Chrome V-Belt 148.99 ea.
- TUF-7127ND6 100 Amp 1 Wire Blk Chrome Serp Belt 191.99 ea.
- TUF-7139ABULL7 100 Amp Silver Bullet 1 Wire Blk Chrome V-Belt 191.99 ea.
- TUF-7139ABULL6G7 100 Amp Silver Bullet 1 Wire Blk Chrome Serp Belt 193.99 ea.
- TUF-7127NK7 140 Amp 1 Wire Blk Chrome V-Belt 170.99 ea.
- TUF-7127NK6G7 140 Amp 1 Wire Blk Chrome Serp Belt 171.99 ea.
- TUF-7140ABULL7 140 Amp Silver Bullet 1 Wire Blk Chrome V-Belt 257.99 ea.
- TUF-7140ABULL6G7 140 Amp Silver Bullet 1 Wire Blk Chrome Serp Belt 260.99 ea.

Tuff Stuff Alternator Accessories

- TUF-7500A Chrome Alternator Case Kit 65.99 kit
- TUF-7600A Chrome Fan and Pulley Kit, Single Groove 23.99 kit
- TUF-7600B Chrome Fan and Pulley Kit, Double Groove 26.99 kit
- TUF-7610E Chrome Alternator Pulley, Single Groove 17.99 ea.



APX-ALT-CAP

Alternator Positive Terminal Cap Red

This is a new reproduction red plastic GM style alternator positive terminal cap and retainer kit. Check alternator to cylinder head clearance before ordering. Some applications are tight.

- APX-ALT-CAP 1964-77 13.95 set



BN-339

Alternator Hardware

All of the correct hardware needed to mount your alternator!

- BN-339 1969-72 BB Lower Stud/Nut 11.99 ea.
- BZ-117 1965-68 BB Hardware Kit 16.99 kit
- BRB-938 1969-72 SB Lower Bolt 4.95 ea.



APX-1138

- APX-1138 1969-72 SB Spacer Brace 17.99 ea.



APX-1038

- APX-1038 1969-72 BB Spacer Brace 15.95 ea.



AWB-1114

- AWB-1114 1964-72 Upper Adj Kit w/ W Bolt 5.99 kit



ABC-23

- ABC-23 1969-72 Bat Cable Clip SB 13.95 ea.

For top of alternator



ATE-5416

- ATE-5416 1969-72 Heater Hose Retainer 7.99 ea.

For top of alternator



AW-506

- AW-506 1964-72 Neg Cable Ground Bolt/Washer 0.95 ea.



G-4962

Alternator Mounting Kits

These complete kits make installing your alternator and bracket easy.

- G-4805 1967 396, 427 16pc 16.99 kit
- G-4645 1967-68 327, 350 16pc 15.99 kit
- G-4918 1968 396, 427 16pc 16.99 kit
- G-4962 1969-74 SB All 15.99 kit

No Volume Discount.



GCS-S6679

BUY'N SAVE
WITH KITS

Alternator Dress Up Kit

This kit is designed to take your stock internally regulated alternator and make it show ready. This kit includes a chrome alternator case, pulley, fan and hardware.

GCS-S6679 1973-85 GM43.99 kit
Note: For 1973-85 internal regulated alternators only.

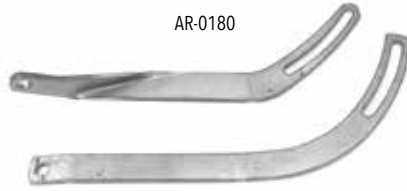

AR-0180

1965-68 SHP Alternator Bracket Kit

Correct upper and lower bracket stamped "GT" for all 1965-68 SB.

AR-0180 1965-68 SHP79.95 kit



GCS-S9487

Billet Alternator Pulleys

Show quality billet alternator pulleys.

GCS-S9487 1 Groove, Satin25.99 ea.
GCS-S9487POL 1 Groove, Polished31.99 ea.
GCS-S9447 2 Groove, Chrome17.99 ea.



GCS-S8867

Billet Alternator Fan

Polished billet aluminum.

GCS-S8867 Polished12.99 ea.

GCS-S9446



Chrome Alternator Fan w/ Pulley

Chrome plated steel OEM style alternator fan with chrome single groove pulley. Includes nut.

GCS-S9446 Chrome15.99 kit

Small Block Alternator Brackets

OE style reproduction alternator brackets for your small block Chevy.



AAB-65L

AAB-65L 1962-68 SB Lower17.95 ea.
Use with AAB-64L if you have headers.



ACE-5333

ACE-5333 1969-72 SB Lower16.99 ea.



AAB-64L

AAB-64L 1962-68 SB Lower39.95 ea.
For exhaust manifolds.



ALB-22

ALB-22 1962-67 SB Lower Early Style41.95 ea.



AAB-3400

AAB-3400 1962-68 SB Upper29.95 ea.



ACE-2956

ACE-2956 1969-72 SB Upper29.99 ea.

Big Block Alternator Brackets

OE style reproduction alternator brackets for your big block Chevy.



AAB-4500

AAB-4500 1965-68 BB Upper19.95 ea.



AK-173

AK-173 1969-72 BB Upper36.95 ea.



AK-175

AK-175 1969-72 BB Lower29.95 ea.



ARZ-0027

ARZ-0027 1965-68 BB Lower46.95 ea.



AA-45KIT

Big Block Alternator Bracket Kit

This is a complete set of alternator brackets and hardware for your 1965-68 Nova big block with short water pump. This kit works on all cars with short water pumps.

AA-45KIT 1965-68 BB Short Pump76.40 kit

BUY'N SAVE
WITH KITS



AKK-301









1969-72 Big Block Alternator Mounting Kit

OE style reproduction of upper-lower brackets, lower mounting stud, lower spacer-brace and upper adjustment bolt w/ special washer.

AKK-301 1969-72 All BB69.99 kit

OE Style Chrome Alternator Brackets







These high quality brackets will give your show car that finishing touch!

	GCS-S9315			GCS-S9637			GCS-S9318	
GCS-S9315	SB Upper SWP.....	14.99 ea.	GCS-S9637	SB Lower LWP (69-75).....	6.99 ea.	GCS-S9318	BB Upper LWP (69-92).....	14.99 ea.
	GCS-S9316			GCS-S9502			GCS-S9638	
GCS-S9316	SB Upper LWP (69-75).....	14.99 ea.	GCS-S9502	BB Lower SWP.....	34.99 ea.	GCS-S9638	BB Lower LWP (69-92).....	6.99 ea.
	GCS-S9317			GCS-S9581			GCS-S9254	
GCS-S9317	SB Upper LWP (76-86).....	15.99 ea.	GCS-S9581	BB Upper SWP.....	14.99 ea.	GCS-S9254	Bracket for Headers.....	12.99 ea.

Note: SWP = Short Water Pump. LWP = Long Water Pump.

Custom Style Alternator Brackets

These chrome plated steel alternator brackets will give your engine a unique custom look that will stand out from the crowd.

	GCS-S9319			GCS-S9320			GCS-S1637	
GCS-S9319	SB Upper SWP.....	14.99 ea.	GCS-S9320	V8 Upper LWP (69-75).....	12.99 ea.	GCS-S1637	SB Upper LWP (76-86).....	17.99 ea.
	GCS-S9321			GCS-S1647			GCS-S1647	
GCS-S9321	SB Upper LWP (76-86).....	12.99 ea.	GCS-S1647	BB Upper LWP (69-92).....	17.99 ea.			



AJ-408

Timing Covers

New covers complete with crankshaft seal.

AJ-408	1968-76 All Small Block.....	48.95 ea.
AJ-850	1965-72 All Big Block.....	46.95 ea.
BTC-650	Correct Attaching Bolts.....	8.95 kit



GCS-S4935

Chrome Timing Covers

Brilliantly polished timing cover with a rigid sealing surface.

GCS-S4932	SB SWP Chrome.....	22.99 ea.
GCS-S4934	SB LWP Chrome.....	23.99 ea.
GCS-S4935	BB All Chrome.....	23.99 ea.
GCS-S4935R	BB All Unfinished Steel.....	23.99 ea.

Note: These covers may not work with some double roller timing chains. Check clearance before starting engine. Doubling of the gaskets or shims may be required to use cover with a short water pump. SWP = Short water pump. LWP = Long water pump.



GCS-S6040C

2 Piece Aluminum Timing Covers

An excellent upgrade for your engine. Rigid sealing surface for positive seal and it looks great, too!

GCS-S6040	SB Polished Billet.....	20.99 ea.
GCS-S6040C	SB Chrome Billet.....	47.99 ea.
GCS-S8422	BB Polished Billet.....	41.99 ea.
GCS-S8422C	BB Chrome Billet.....	62.99 ea.

Note: These covers may not work with some double roller timing chains. Check clearance before starting engine. Doubling of the gaskets or shims may be required to use cover with a short water pump.

ATP-36



ATP-07

Timing Cover Pointers

Correct pointer for adjustment of engine timing.

ATP-07	1965-68 SB	7.99 ea.
ATP-36	1969-72 SB	10.99 ea.
ATP-47	1965-72 SB w/ 7" Bal	19.99 ea.
ATP-07	1965-72 BB SHP w/ 8" Bal	7.99 ea.

GCS-S4961



Chrome Adjustable Timing Pointers

Provides a convenient way to adjust and verify your engine's ignition timing. Finished brilliant chrome plated steel.

GCS-S9178	SB 7"	7.99 ea.
GCS-S9179	SB 8"	7.99 ea.
GCS-S4961	BB 8"	3.99 ea.
GCS-S9180	BB 9" Adjustable	4.99 ea.

GCS-S6041



GCS-S6042C

SB Billet Timing Cover Pointer

Provides a convenient way to adjust and verify your engine's ignition timing. Adjustable and can be used with 6" or 7" balancers.

GCS-S6041C	Chrome Plated Billet	26.99 ea.
GCS-S6042	Ball Milled	28.99 ea.
GCS-S6042C	Ball Milled Chrome	28.99 ea.
GCS-S4960	Chrome Plated Steel	4.99 ea.
GCS-S6041	Billet	24.99 ea.

GCS-S2083



Chrome Holley Carburetor Throttle Return Kit

Designed to make mounting the spring a snap! Works on most Holley carburetor applications.

GCS-S2083	Holley	14.99 kit
-----------	--------	-----------

Note: Due to the universal nature of this part fitting and/or modifications may be required.



ACE-1400

Distributor Hold Down

Correct retaining hardware for distributors.

ACE-1400	All V8	4.95 kit
----------	--------	----------



GCS-S5116

Custom Distributor Hold Down Kit

Designed to secure your distributor settings and look good doing it. Choose from chrome or billet.

GCS-S4116	Chrome	4.99 ea.
GCS-S5116	Billet	17.99 ea.



GRC-12835

Radio Capacitor

Came from the factory on all cars with radio. Correct length lead wire & brass connector. Stamped 1964452 "DR" & ".3MF" as original.

GRC-12834	1964-71 3MF	29.99 ea.
GRC-12835	1970-74 5MF	29.99 ea.

N-2441



Tune Up Kit

AC Delco tune up kit with new points, condenser and rotor.

N-2441	1964-72 All	45.95 ea.
--------	-------------	-----------



ALI-65



ALI-3119

BAN-516

Coil Bracket

OE style reproduction of original comes with retaining screw.

ALI-65	1965 L79	99.95 ea.
ALI-3119	All V8	19.99 ea.
BAN-516	SEMS Bolts	1.95 pr.



ALI-1504

A-193

Starter Solenoid Wire Clip

Correct clip for retaining wire harness to solenoid.

ALI-1504	1964-67 All V8	17.99 ea.
A-193	1968-72 All V8	24.95 ea.



GCS-S9366

Chrome Ignition Coil Bracket

This brightly chrome plated ignition coil bracket will look great in your engine compartment. Fits most round cylinder style ignition coils.

GCS-S9366	Coil Bracket	7.99 ea.
-----------	--------------	----------



GCS-S3112

HEI Distributor Pigtail

GCS-S3112	All	11.99 ea.
-----------	-----	-----------

A2525

1971244



Distributor Cap

Choose from AC Delco replacement distributor cap or OE style reproduction distributor cap with GM numbers. Red cap features heavy duty brass terminals for high performance engines.

A2525	Red Cap	79.95 ea.
1971244	Black Cap	69.95 ea.
AAD-308	Replacement	22.95 ea.

ADS-2100-SC-CLEAR



ADS-2100-SC-RED

HEI Distributor

Chrome aluminum HEI electronic distributor with built-in 50K coil.

- ADS-2100 All V8 72.99 ea.
 - ADS-2100-SC-RED All V8, Red Super Cap 102.99 ea.
 - ADS-2100-SC-CLEAR All V8, Clear Super Cap 108.99 ea.
 - GCS-S3938-BLUE I6 Blue Super Cap* 67.99 ea.
- * For 292 Inline 6 cyl. Only.



Accel Replacement HEI Distributor

Using all new components, these distributors feature: High performance ACCEL Electronics. All new components-housing castings, ce. Direct plug-in replacement with factory type connector. Fits standard deck height small and big block engines. Coil Not Included!

- ACCEL-59107 All w/ HEI 142.99 ea.
- No volume discount.



MSD-8362



MSD HEI Distributor

For value conscious enthusiasts, the Street Fire HEI is a great choice! We know the importance of a centrifugal advance in a distributor so our engineers made sure that the Street Fire received an advance assembly with coated weights and welded weight pins (not just pressed in like other models). Another area that you cannot afford to scrimp on is with a distributor gear. The Street Fire is fit with the same gear that is used on our Pro-Billet models. The metallurgy of this gear has been refined for years to perform through the harshest conditions

- MSD-8362 All, Red Cap 4 Pin* 171.99 ea.
 - MSD-8365 All Billet, Red Cap 4 Pin* 457.99 ea.
- Note: Standard deck height blocks only. Will not fit gen 5 and 6 big blocks. *Refers to the amount of terminals on the ignition module. No volume discount.

MSD-8360



MSD Pro Billet Distributor

The Pro-Billet Ready-to-Run distributor is the perfect upgrade for outdated points distributors or bulky HEIs. Simply install the distributor in the engine, connect three wires, the coil and fire it up!

- MSD-8360 Chevy V8* 369.99 ea.
 - MSD-85551 Chevy V8** 287.99 ea.
- *Does not have nor can accept a vacuum advance canister.
 **Must be used with a MSD 6,7, or 8 ignition box.
 Note: Standard deck height blocks only. Will not fit gen 5 and 6 big blocks. No volume discount.



Mallory Unilite Distributor

A legend returns - the tried and true Mallory Unilite Distributor line is back! The easy three wire hookup of the Unilite makes running a stock coil, a Mallory performance coil and even a Mallory HyFire CD ignition a snap. Supplied with a quality cap and rotor, the Mallory Unilite also provides a fully adjustable mechanical advance to dial in the perfect timing curve for a multitude of engine combinations. The Unilite features a compact housing that lends itself well to applications where space is a premium due to tight firewall clearance or blower applications.

- MAL-3748201 All SBC, BBC* 325.99 ea.
- *Standard deck height blocks only. Will not fit gen 5 and 6 big blocks. No volume discount.



MSD-6201

MSD Ignition

An MSD Ignition will improve the overall performance of your engine thanks to its high output capacitive discharge sparks. Below 3,000 rpm the ignition delivers multiple sparks that will clean up the idle, improve starting and throttle response. If you're looking to improve the performance of your modified mill, we have the answer. Whether you've done a cam swap, or bolted on a carb, intake and headers the 6A is a surefire way to harness all the ponies under your hood. Step up to the 6AL to have an engine saving rev limiter.

- MSD-6201 Red All 6A 237.99 ea.
 - MSD-6425 Red All 6AL 275.99 ea.
 - MSD-64253 Black All 6AL 275.99 ea.
 - MSD-6421 Red All 6AL-2 328.99 ea.
- No volume discount.

1115270



Detail

Coil

Choose from our new OE style reproduction Delco coils with GM numbers or GM replacement coil.

- 1115287 1968-72 BB 139.95 ea.
 - 1115270 1968-72 SB 139.95 ea.
 - 1115263 1967-72 Trans. Ign.* 149.95 ea.
 - 1115293 1970-72 Most V8 139.95 ea.
 - GAC-505 1964-72 All Replace 39.95 ea.
- *427/454 transistor ignition. No Volume Discount.



GCS-S2039BK

External Ignition Coils

Choose from our upgraded external ignition coils. 45,000-volt output. Anodized finish, includes pigtails and hardware for installation.

- GCS-S2039BK All, Black 55.99 ea.
- GCS-S2039BLU All, Blue 55.99 ea.
- GCS-S2039C All, Chrome 55.99 ea.
- GCS-S2039RED All, Red 60.99 ea.



APJ-5240

Ground Strap Kit

Correct braided copper wire and ends complete with OEM screws.

- APJ-5240 1964+ (3 pc.) 19.95 kit



APX-1300 APX-8100 APX-1200

Wire Separators

Correct spark plug wire separators.

APX-1300	1969-72 SB/BB Left Rear.....	16.95 ea.
APX-1200	1969-72 SB Left Front.....	17.99 ea.
APX-8100	All BB Right Side.....	15.95 ea.



AX-423 AX-486 AX-486A

Spark Plug Wire Stands

New exact reproduction of originals

AX-423	All SB (right side).....	14.95 ea.
AX-486A	1968 All SB (left side).....	27.95 ea.
AX-486	1969-72 All SB (left side).....	27.95 ea.

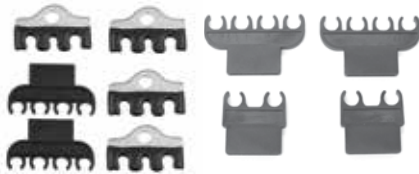

APX-5022 APX-5023

Valve Cover Spark Plug Wire Loom Kits

Correct spark plug wire separators for valve covers

APX-5022	SB 6pc.....	19.95 kit
APX-5023	BB 4pc.....	11.95 kit



"Dated" Spark Plug Wire Set

New exact reproduction wire set correctly dated for your specific car, pre-cut and ready to install! Each set features correct colored wires and correct angle "cut" boots. Please give your sales rep your desired date. Non-HEI cars only. Here's how to order:

ALL-(year)(block)(quarter)..... 79.99 set
 *For example, if the build date of your car was on or before January 15th of the model year, order 3rd quarter of the previous year. If the build date was after January 15th of the model year, order 1st quarter of that year. i.e. A 1970 Nova built on or before Jan 15th of 1970 would receive 70BB1Q.



AHC-1508



AHC-2508

Spark Plug Wire Sets

New pre-cut OEM replacements.

AHC-1508	All SB.....	39.95 set
AHC-2508	All BB.....	39.95 set
AHC-3508	All w/ HEI.....	52.95 set



MAL-937C

Mallory Pro Spark Plug Wires

Burning spark plug boots in high heat applications is a thing of the past with Mallory's high temp ceramic boot spark plug wires. The ceramic boot is capable of withstanding temps up to 2,000 degrees F, making them ideal for applications with close tolerance headers and any other application where boot failure is an issue. These universal sets come with HEI type and socket type distributor ends. Cut and crimp to fit. 90 Degree boots typically fit small block and the 135 degree boots typically fit big block.

MAL-937C	90 Degree Red.....	112.95 set
MAL-947C	135 Degree Red.....	112.95 set
MSD-35051	Universal Crimper Tool.....	88.99 ea.

No volume discount.



MSD-35593



MSD Ignition Spark Plug Wires

Engineered from the inside out, the 8.5 offers everything you have ever wanted in a wire; incredibly low resistance without electronic interference! In a single 12 inch length of Super Conductor Wire there is only 40 - 50 ohms of resistance!

Without Headers

MSD-31359	Red, SBC 350 HEI w/o Headers.....	96.99 kit
-----------	-----------------------------------	-----------

With Headers

MSD-35593	Black, SBC 350 HEI* Cap.....	99.99 kit
MSD-35599	Red, SBC 350 HEI* Cap.....	99.99 kit
MSD-35603	Black, BBC 350 HEI* Tower Cap... ..	103.99 kit
MSD-35609	Red, BBC 350 HEI* Tower Cap... ..	103.99 kit
MSD-35653	Black, SBC 350 HEI* Tower Cap... ..	101.99 kit
MSD-35659	Black, SBC 350 HEI* Cap.....	101.99 kit

*Works on any HEI or MSD style cap with male terminals.

No volume discount.

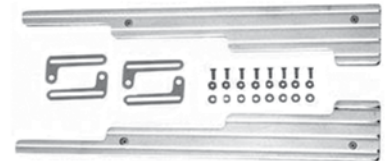

GCS-S6038



GCS-S6038X

Billet Spark Plug Wire Looms

These wire looms will keep your spark plug wires neat and organized, minimizing wear on the wires. Also prevents cross firing and grounding of the wires. Choose from plain, ball milled, or milled flames in either polished billet or chrome billet. Includes mounting hardware.

GCS-S6039	Plain, Polished.....	47.99 kit
GCS-S6039C	Plain, Chrome.....	59.99 kit
GCS-S6038	Ball Mill, Polished.....	41.99 kit
GCS-S6038C	Ball Mill, Chrome.....	62.99 kit
GCS-S6038X	Flames, Polished.....	52.99 kit
GCS-S6038XC	Flames, Chrome.....	64.99 kit

Note: Fits up to 9.5 mm wires.



Universal Chrome Wire Looms GCS-S7251

These wire looms will keep your spark plug wires neat and organized minimizing wear on the wires. Also prevents cross firing and grounding of the wires.

GCS-S7251 Universal20.99 kit
 Note: Fits up to 9 mm wires.

AC43



AC Delco Spark Plugs

This is a brand new set of 8 spark plugs for your Chevrolet. These high quality reproduction AC Delco spark plugs feature the correct green AC and markings as original.

AC43 1964-70 #4359.95 set
 AC44 1964-70 #4459.95 set
 AC45 1964-70 #4559.95 set

Note: The number on the plug refers to its operating temperature. The lower number is a cooler running plug which is typically found on the SHP high performance engines. A hotter, higher numbered plug would be used in engines where plug fouling may be, or is a problem.



APX-650

Spark Plug Heat Shield Kit SB

Correct die stamped shields and arms for most small blocks without Rams Horn style manifolds. Complete with mounting hardware.

APX-650 1964-72 SB.....36.95 kit
 BXX-650 Bolts (4)1.00 kit

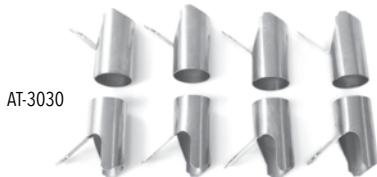

AT-3030

OEM Style Spark Plug Heat Shield Kit BB

This is a set of correctly stamped spark plug heat shields which are Silver Cadmium plated.

AT-3030 1965-72 BB49.95 kit



Spark Plug Heat Shield Kit BB

Correct stamped shields for various Chevrolet cars with BB engines (8pcs).

APX-6584

APX-6584 1965-72 BB38.95 kit



AD-052

AZ-840

Smog Tube & Extension

Correct pre-bent powder coated AIR smog tubes and extensions.

AD-252 1969-72 SB Tubes 89.95 pr.
 AD-052 1969-72 BB Tubes 89.95 pr.
 AZ-840 1967-72 Extension 8.95 ea.



ASH-695

Smog Hose Kit

Original OEM ribbed hose complete with white stripe vacuum hose, T fittings and clamps.

ASH-695 All SB Complete41.95 kit
 ASH-698 All BB Complete41.95 kit
 CPN-100 OEM Vacuum Hose Only1.95 pr. ft



AVC-542

1968 SHP Valve Covers

Accurate reproductions of the original 1968 Special High Performance (SHP) valve covers in chrome or ready to paint EDP coating.

AVC-542 Chrome 139.99 pr.
 AVC-543 Paintable..... 129.99 pr.



GCS-S6142

GCS-S6142G

Fabricated LS1 Valve Covers

2.5" height to clear aftermarket valve train. Includes oil cap, O-ring type gasket and bolts. Available with or without mounts for coil brackets.

GCS-S6141 LS1, No Coil Bracket Mounts, Anodized192.99 ea.
 GCS-S6141C LS1, No Coil Bracket Mounts, Chrome 216.99 pr.
 GCS-S6141POL LS1, No Coil Bracket Mounts, Polished 209.99 ea.
 GCS-S6142 LS1, w/ Coil Bracket Mounts, Anodized 168.99 pr.
 GCS-S6142C LS1, w/ Coil Bracket Mounts, Chrome 204.99 pr.
 GCS-S6142POL LS1, w/ Coil Bracket Mounts, Polished 192.99 pr.
 GCS-S6142G LS1 O-Ring Type Gasket 7.99 pr.
 GCS-S6142BOLT LS1 Valve Cover Bolt Kit 7.99 kit
 GCS-S6143 LS1 Coil Mounting Brackets 24.99 pr.

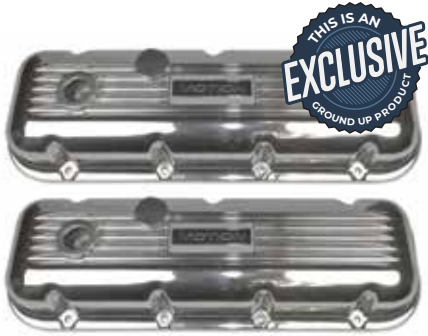

MOTION-VC

"Motion" Valve Covers

Original style Cal Custom finned valve covers featuring the notorious Baldwin Motion die cast logos.

AVC-100 Most BB (Blank)..... 179.95 pr.
MOTION-VC Most BB "Motion" 289.95 pr.
Note: 2-5/8" - 3" inside clearance.



ATE-4207

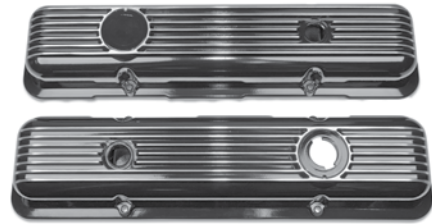

ATE-4207-BLK

Finned Aluminum Valve Covers

Exact reproduction of original GM high performance valve covers.

ATE-4207 SB..... 229.99 pr.
ATE-4207-BLK SB Black 229.95 pr.
HVC-28 Flag Decal..... 8.95 ea.



GCS-S6047BK

Small Block Center Bolt Ball Milled Valve Covers

These aluminum valve covers are a great custom touch to any street machine or sleeper.

GCS-S6047BK Center Bolt Small Block..... 111.99 pr.
Fits 1987 and newer small block with center bolt heads except LS.



GCS-S6145BK



GCS-S614POL

Fabricated Tall Height Valve Covers

High quality fabricated aluminum valve covers. Mounting hardware included. Available with or without breather holes.

GCS-S6144C	SB, No Hole, Chrome	179.99 pr.
GCS-S6144POL	SB, No Hole, Polished	144.99 pr.
GCS-S6144BK	SB, No Hole, Black	156.99 ea.
<i>3-3/4" height</i>		
GCS-S6145	SB, Flat Top, w/ Hole, Anodized	144.99 pr.
GCS-S6145C	SB, Flat Top, w/ Hole, Chrome	156.99 pr.
GCS-S6145POL	SB, Flat Top, w/ Hole, Polished	144.99 pr.
GCS-S6145BK	SB, Flat Top, w/ Hole, Black	156.99 pr.
GCS-S6147	SB, Flat Top, No Hole Anodized	119.99 pr.
GCS-S6147C	SB, Flat Top, No Hole Chromw.....	148.99ea.
GCS-S6147POL	SB, Flat Top, No Hole Polished	119.99 ea.
<i>3-7/8" height</i>		
GCS-S6243	BB, Long Screw, w/ Hole, Anodized	164.99 ea.
GCS-S6243C	BB, Long Screw, w/ Hole, Chrome	192.99 ea.
GCS-S6243POL	BB, Long Screw, w/ Hole, Polished	179.99 ea.
GCS-S6244	BB, Long Screw, No Hole, Anodized	168.99 pr.
GCS-S6244C	BB, Long Screw, No Hole, Chrome	192.99 pr.
GCS-S6244POL	BB, Long Screw, No Hole, Polished	161.99 pr.
GCS-S6244BK	BB, Long Screw, No Hole, Black	192.99 ea.
<i>3-1/2" height</i>		
GCS-S6248	BB, Short Screw, w/ Hole, Anodized	162.99 pr.
GCS-S6248C	BB, Short Screw, w/ Hole, Chrome	186.99 ea.
GCS-S6248POL	BB, Short Screw, w/ Hole, Polished	180.99 pr.
GCS-S6248BK	BB, Short Screw, w/ Hole, Black	204.99 ea.
GCS-S6249	BB, Short Screw, No Hole, Anodized	168.99 ea.
GCS-S6249C	BB, Short Screw, No Hole, Chrome	186.99 ea.
GCS-S6249POL	BB, Short Screw, No Hole, Polished	180.99 ea.
<i>3-1/2" height</i>		



GCS-S6047BK

Small Block Tall Valve Covers

These high quality small block Chevy valve covers are a great way to dress up your engine, as well as gain some extra clearance for roller rockers.

GCS-S6336	Chevrolet Logo, Black	241.99 pr.
GCS-S7618	Chevrolet Logo, Orange	230.99 pr.
GCS-S6341POL	Chevrolet Logo, Polished.....	314.99 pr.
GCS-S7617	383 Stroker Logo, Black.....	209.99 pr.
GCS-S7619	383 Stroker Logo, Orange	220.99 pr.
GCS-S6342POL	383 Stroker Logo, Polished	314.99 ea.



AVC-540

1967 Chevrolet Script Valve Covers

Excellent reproductions of the original stamped "Chevrolet" valve covers in chrome or ready to paint EDP coating. These valve covers feature the correct wire retainers and "O" stamp.

AVC-540	Chrome	169.99 pr.
AVC-541	Paintable	129.99 pr.



ALS-1065



Original Style Chrome Valve Covers

These OE style reproduction covers offer the highest quality chrome plating, correct wire stands and factory oil deflectors "drippers". Valve covers are available with a left side slant to increase booster clearance in tight engine compartments. Also available in tall style to fit roller rockers.

ALS-1065	All BB w/o Slant.....	99.95 pr.
ALS-1165	All BB w/ Left Side Slant	99.95 pr.
ACC-3362	All BB w/o Drippers	38.99 pr.
ACC-3365	All BB w/ Slant w/o Drippers	31.99 pr.
ALS-1065XT	All BB Tall w/o Left Slant w/o Drippers.....	89.95 pr.
ALS-1165XT	All BB Tall w/ Left Slant w/o Drippers.....	89.95 pr.



BUY'N SAVE
WITH KITS

XA-101

Big Block Valve Cover Kit

Save money on our complete kit! All kits come complete with the following items:

(2) valve covers, (2) gaskets, valve cover retainers and TR bolts, (2) V.C. grommets, V.C. oil cap, V.C. elbow and Hose and V.C. wire separators.

XA-101	w/o Left Slant w/ Drippers	130.39 kit
XA-101S	w/ Left Side Slant w/ Drippers*	130.39 kit
<i>*Use slanted valve covers when brake booster clearance may be an issue. OE kits with silver gaskets, correct oil cap and Tonawanda decal.</i>		
XA-101-OE	w/o Left Slant w/ Drippers	163.70 kit
XA-101S-OE	w/ Left Slant w/ Drippers	163.70 kit
<i>*Use slanted valve covers when brake booster clearance may be an issue.</i>		

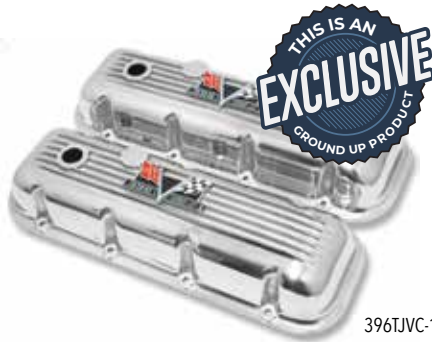

396TJVC-1

"Turbo Jet" Valve Covers

Cal Custom finned valve covers featuring the famous "Turbo Jet" medallions.

396TJVC-1	All BB.....	229.95 pr.
427TJVC-1	All BB.....	229.95 pr.
454TJVC-1	All BB	229.95 pr.
502TJVC-1	All BB.....	229.95 pr.
572TJVC-1	All BB	229.95 pr.

2-5/8" - 3" inside clearance. Will work with most roller rockers.



427VC-1

"427" Valve Covers

Like our "YENKO" covers with cast "427" medallions.

427VC-1	Most BB "427"	229.95 pr.
427VC-R	Most BB "427" Red	229.95 pr.

2-5/8" - 3" inside clearance. Will work with most roller rockers.

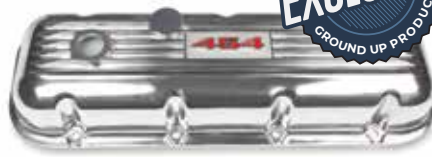

454VC-R

"454" Valve Covers

Original Cal Custom style valve covers featuring red "454" medallions.

454VC-R	Most BB "454"	229.95 pr.
---------	---------------------	------------

2-5/8" - 3" inside clearance. Will work with most roller rockers.



HARREL-VC

Dick Harrel Aluminum Valve Covers

"Cal Custom" finned aluminum covers feature the notorious Dick Harrel die cast medallions.

HARREL-VC	Most BB.....	229.95 pr.
-----------	--------------	------------

2-5/8" - 3" inside clearance. Will work with most roller rockers.



SS427VC-R

"SS 427" Valve Covers

Original Cal Custom style valve covers featuring red "SS 427" medallions.

SS427VC-R	Most BB "SS 427"	279.95 pr.
-----------	------------------------	------------

2-5/8" - 3" inside clearance. Will work with most roller rockers.



YSCVC-1

"Yenko" Valve Covers

These limited edition "Cal Custom" style finned aluminum covers feature the notorious "YENKO" Red, White and Blue die cast logos.

YSCVC-1	Most BB "YENKO"	229.95 pr.
---------	-----------------------	------------

2-5/8" - 3" inside clearance.



AT-3662



AT-3666

Small Block Valve Covers

New original style early small block Chevrolet covers. These covers come ready to install in correct Chevrolet Orange or chrome plated.

AT-3662	SB Chrome Covers.....	119.95 pr.
AT-3666	SB Orange Covers	99.95 pr.



GCS-9215B

Black Painted Valve Covers

This is a pair of high quality tall black painted valve covers. A great inexpensive custom touch to any street machine or sleeper!

GCS-9215B	1964-77 SB.....	31.99 pr.
-----------	-----------------	-----------



ALS-1165-OJ

Big Block Valve Covers – Chevrolet Orange

This is a pair of brand new big block valve covers painted in Chevy orange. These valve covers are correct for most big blocks and will fit cars with power brakes.

ALS-1165-OJ	All Big Block.....	109.99 pr.
-------------	--------------------	------------



Valve Cover Gaskets

AFP-057	All SB.....	13.95 pr.
AFP-059	All BB.....	13.95 pr.



APB-1027

APB-1023

Valve Cover Retainers OEM Bolt Kits

Correct steel stamped zinc plated retainers & OEM bolts.

APB-1023	SB TR Bolts (16 pc.).....	14.95 kit
APB-2023	BB TR Bolts (28 pc.).....	25.99 kit
APB-1027	SB M Aluminum (8 pc.).....	16.99 kit



APO-2043

APR-2136

Valve Cover Oil Caps

Choose from either chrome GM replacement, chrome reproduction with correct "S", or black rubber push-in cap.

APX-5763	Replacement.....	6.95 ea.
APR-2136	Reproduction "S".....	16.95 ea.
APO-2043	Rubber "OIL".....	5.95 ea.



APB-3508

APB-3509

Valve Cover Grommet Original GM

APB-3508	All SB.....	8.99 pr.
APB-3509	All BB.....	7.95 pr.



APT-3509

APT-3960

Valve Cover Elbows

Correct GM steel valve cover elbows.

APT-3960	All SB.....	12.95 ea.
APT-3509	All BB.....	11.95 ea.



APH-3843

APH-2109

Valve Cover Hose

Correct marked OEM hose which extends from valve cover to air cleaner base. Choose from open or closed element.

APH-3961	All SB Open.....	11.95 ea.
APH-3843	All BB Open.....	4.95 ea.
APH-2109	1970-72 BB Closed.....	12.95 ea.



AM2-3628

1962-67 V8 Oil Pan Conversion

This kit is essential when converting from a 6 cylinder to a small block V8 engine. Includes standard volume oil pump, oil pan, dip stick, dip stick tube, oil pump pick up tube and oil pump shaft.

AM2-3628	319.99 kit
----------	-------	------------

No volume discount.



GCS-S8442BK

Small Block Finned Aluminum Oil Pans

These finned aluminum oil pans will help keep your oil cooler and add some custom style to your street machine or sleeper.

GCS-S8442BK	1968-79 SB	99.99 ea.
<i>2-piece rear main seal, drivers side dipstick.</i>		
GCS-S8443BK	1980-85 SB	96.99 ea.
<i>2-piece rear main seal, passenger side dipstick.</i>		
GCS-S8444BK	1986 + SB	99.99 ea.
<i>1-piece rear main seal, passenger side dipstick.</i>		



AEH-999

Oil Pans

OEM supplier.

AJ-221	1968-72 SB w/out SHP	129.99 ea.
AEH-999	1968-72 All BB.....	199.99 ea.



APC-744

Oil Pan Clip

Correct clip for retaining positive battery cable routing to solenoid.

APC-744	All SB-BB.....	5.95 ea.
---------	----------------	----------



BPO-1988

Oil Drain Bolt/Washer

Original GM.

BPO-1988	All SB/BB	6.95 ea.
----------	-----------------	----------



ACP-15B

Oil Pan Gasket Set

Correct OEM gaskets.

ACP-15B	All SB.....	19.95 ea.
ACP-2BB	All BB.....	16.95 ea.



BOP-2002

Oil Pan Attaching OEM Bolt Kit

Correct "L" head marked bolts for attaching pan to block.

BOP-2001	All SB (18 pc.).....	9.95 ea.
BOP-2002	All BB (24 pc.).....	14.99 ea.



AJ-4

Oil Pan Baffle / Windage Tray

Often installed on most High Performance cars, this "windage tray" was used to keep oil from splashing the crankshaft. A MUST!

AJ-4	Small Block	44.99 ea.
AJ-6	Big Block	23.95 ea.



NFX-25



NF-25

Oil Canister - Filter

OE style reproduction of early canister style filter.

NFX-25	PF-25 AC Filter "White"	24.99 ea.
NF-25	PF-25F AC Filter "Blue"	9.99 ea.



KN-HP2002



KN-PS2002



K&N Oil Filters

K&N Performance Oil Filters have been specially designed for professional installers and service providers. Their high flow design can help to improve engine performance by reducing oil filter restriction. Performance Gold Oil Premium Wrench-Off Oil Filters have become a favorite among consumers for its durability and easy removal. Our Performance Silver Oil Filters have a fluted canister shape so they can be removed with a traditional oil filter wrench commonly available to commercial installers. These Performance oil filters provide outstanding filtration and engine protection throughout their service life. They are engineered to handle all grades of synthetic, conventional and blended motor oils. The pleated media provides high capacity making them suitable for extended oil change intervals when used in accordance with the vehicle and motor oil manufacturers recommendation.

KN-HP2002	1962-79 Gold Wrench Off.....	11.99 ea.
KN-PS2002	1962-79 Silver Standard Fluted.....	8.99 ea.

No Volume Discount.



N-133

N-137

N-142

Oil Pressure Fittings

N-137	1968+ All SB	6.99 ea.
N-133	All BB w/o SHP	16.95 ea.
N-142	All BB w/ SHP	26.95 ea.
N-A6474	Back of Gauge Fitting	6.95 ea.



GAC-310



GAC-110

Oil Pressure Switches

Correct GM switches for cars without manual gauges.

GAC-310	1969 w/ Gauges	33.95 ea.
GAC-110	1970-72 w/ Gauges	11.95 ea.
GAC-110	1964-72 w/o Gauges	11.95 ea.



Oil Canister Decal

HOC-28	1962-67	5.99 ea.
--------	---------------	----------



N-1131



CHQ-3200

Oil Pressure Lines

Correct material lines with correct fittings for all cars with gauges.

N-1131	1964-67 (Steel Coiled).....	33.95 ea.
CHQ-3200	1968+ (Black Plastic).....	9.99 ea.



GCS-S4994BA

Chrome Dipsticks and Tubes

Show quality dipsticks are an excellent upgrade to any engine compartment. Includes dipstick & tube.

GCS-S9422	Powerglide	13.99 ea.
GCS-S9421	TH350	12.99 ea.
GCS-S9421BA	TH350 Billet Handle	21.99 ea.
GCS-S4994	TH350 34"	13.99 ea.
GCS-S4994BA	TH350 34" Billet Handle.....	17.99 ea.
GCS-S4995	TH400 24"	10.99 ea.
GCS-S4995BA	TH400 24" Billet Handle.....	14.99 ea.

ATE-1576
Detail



ATE-1567
Detail



ATE-1576

Oil Dipstick Kits

Complete with tube and gauge (stick)

ATE-1567	1968-79 SB (Green Dot)	31.99 ea.
ATE-1576	1965-72 BB (Yellow Dot).....	49.95 ea.



GCS-S5005

Chrome Dipsticks w/ Braided Tubes

Stainless steel braided tube with chrome handle.

Bellhousing Mount

GCS-S5004	TH350	42.99 ea.
GCS-S5005	TH400	42.99 ea.
GCS-S5006	TH700-R4.....	42.99 ea.

Firewall Mount

GCS-S5104	TH350/TH400 29"	48.99 ea.
GCS-S5106	TH700-R4	48.99 ea.



GCS-S5002

Billet Engine Dipstick with Braided Tube

Show quality billet aluminum dipstick with braided tube.

GCS-S5002	1968-79 SB	36.99 ea.
GCS-S5001	1980-95 SB.....	36.99 ea.
GCS-S5003	1968-90 BB.....	42.99 ea.

Note: Oil level varies depending on the oil pan used. You may need to mark the dipstick with your own new full level mark.



GCS-S6060

Billet Aluminum Engine Dipstick

Show quality dipstick with billet handle. 11.5" length.

GCS-S6060	Billet Handle	15.99 ea.
-----------	---------------------	-----------

Note: Oil level varies depending on the oil pan used. You may need to mark the dipstick with your own new full level mark.



GCS-S4957



GCS-S4957BA

Chrome/Billet Dipsticks & Tubes

Show quality dipsticks with matching tubes. A great upgrade to any engine compartment!

GCS-S4957	1968-79 SB, Chrome, 19"	5.99 ea.
GCS-S4957BA	1968-79 SB, Billet, 19"	10.99 ea.
GCS-S9420	1980-82 SB, Chrome, 23"	7.99 ea.
GCS-S9420BA	1980-82 SB, Billet, 23"	12.99 ea.
GCS-S9231	1983-85 SB, Chrome, 24.5"	9.99 ea.
GCS-S9231BA	1983-85 SB, Billet, 24.5"	10.99 ea.
GCS-S4958	1968-90 BB, Chrome, 21"	7.99 ea.
GCS-S4958BA	1968-90 BB, Billet, 21"	10.99 ea.

Note: Oil level varies depending on the oil pan used. You may need to mark the dipstick with your own new full level mark.

Holley



Holley LS Swap Oil Pan

GM's popular LS engines are finding their way into a large variety of vehicles. They make great power, plus they're very durable and reliable. Unfortunately, the factory LS pans don't always fit or they hang too low for today's hot rods. Holley's new LS Retro-fit Engine Oil Pan is designed to help! It provides maximum clearance to the chassis and ground, plus provides an OEM fitment for durability and proper sealing.

- Provides OEM fitment- OEM oil filter mounting, OEM oil cooler port provision, OEM engine NVH suppression, OEM flange gasket and sealing, proper structural rigidity and OEM bellhousing attachments.
- Traditional high-quality cast aluminum appearance with clean exterior styling.
- Provides maximum clearance to chassis.
- Cast and machined aluminum.
- Complete kit including sump baffle, pick-up tube, sump plug, oil filter stud & oil passage cover.
- Fits GM rear wheel drive applications that were originally equipped with a Small Block or Big Block Chevy engine and traditional rear sump oil pan*.

HOL-302-2 1968-74 All356.99 ea.
Maximum crankshaft stroke = 4.25"

*Engine location may need to be adjusted (up / down or fore / aft) for cross member or steering linkage clearance depending on the vehicle, steering configuration and chassis type.

No volume discount.



AMX-96



Motor Mounts OE

These new motor mounts are from GM's original supplier! MADE IN USA!!!

ART-2289 1968-74 SB Except 1969-74 35032.99 pr.
AMX-96 1969-74 350, BB69.99 pr.

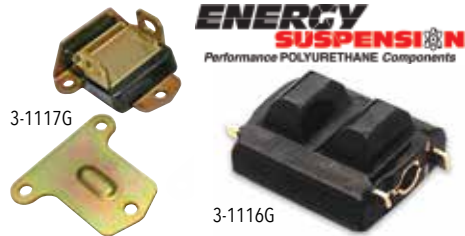

3-1117G

3-1116G

Poly Motor Mounts

Energy Suspension motor mounts can take the abuse of today's high performance engines. Poly bushings can last longer than stock rubber mounts while handling more power.

Add G to the part number for black.

Add R to the part number for red.

Example: 3-4114G is for 68-72 black.

3-1114_ 1968-72 SB 2-5/8" x 3/4" H.....44.99 ea.

3-1117_ 1969-72 BB 2-3/8" x 1-3/16" H.....48.99 ea.

3-1116_ 1973-79*29.99 ea.

Two mounts required per car. *You must reuse your original clamshells on the 1973-79 applications by drilling out the rivets and replacing the rubber insert with the new poly mount.

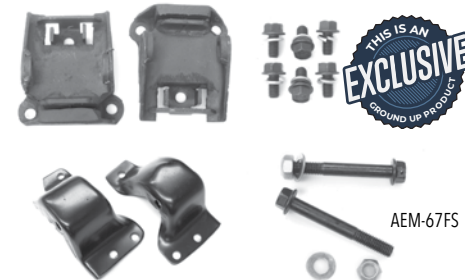

AEM-67FS

Engine Mounting Kits

These convenient engine mounting kits make it easy to convert from a 6 cylinder to a small block or from a small block to a big block. Each kit includes motor mounts, frame brackets, attaching bolts, thru-bolts and frame bracket bolts.

AEM-67FS 1968-74 SB exc 1969-74 35075.06 kit

AEM-67FB 1968 All BB99.86 kit

AEM-69FZO 1969-74 350 OEM.....114.56 kit

AEM-69FBO 1969-74 All BB OEM.....134.23 kit

1973-74 may require some frame drilling.



ENG-67FS-G

Poly Engine Mount Kits

Same as our OE style engine mount kits with upgraded Energy Suspension Poly motor mounts. The poly mounts can take the abuse of today's high performance engines, yet still absorb drive-line vibrations. They are available in Poly Graphite black or red.

ENG-67FS-G 1968-74 SB 307-327 Black129.69 kit

ENG-67FS-R 1969-74 SB 307-327 Red.....129.69 kit

ENG-69FZO-G 1968-74 SB 350 Black154.42 kit

ENG-69FZO-R 1968-74 SB 350 Red154.42 kit

ENG-67FB-G 1968 BB 396-454 Black.....154.49 kit

ENG-67FB-R 1968 BB 396-454 Red154.49 kit

ENG-69FBO-G 1969-74 BB 396-454 Black166.45 kit

ENG-69FBO-R 1969-74 BB 396-454 Red.....166.45 kit

No Volume Discount.



AQW-1339



APX-2339

Frame Brackets

OE style reproduction of the long discontinued GM brackets for mounting the engine to frame of car. Sold in matched pairs.

AFM-23 1962-67 SB.....74.95 kit

AQW-1339 1968-74 SB exc 1969-74 35034.99 pr.

ATE-5978 1968 BB.....65.99 pr.

AR-397 1969-74 35059.95 pr.

ACE-9412 1969-74 BB74.99 pr.

Frame Bracket Attaching Bolt Kit

Correct OEM bolts, washers and locking nuts as original.

APX-2339 1964-72 All V8.....6.95 kit



BJ-998

Motor Mount Attaching Bolt Kit

Correct style bolts for attaching mount to block.

BJ-998 All (12 pc).....8.95 kit



ATW-2853

Motor Mount Clip

Correct clip for attaching positive cable to right side motor mount.

ATW-2853 Most V8.....19.95 ea.

APB-7057

Motor Mount "Thru" Bolt Kit

Correct OEM bolts for retaining mount to frame bracket. Comes complete with special high strength washers and cadmium plated locking nuts as original.

APB-9057 4.5"9.99 kit

APB-7057 3.5"6.95 kit

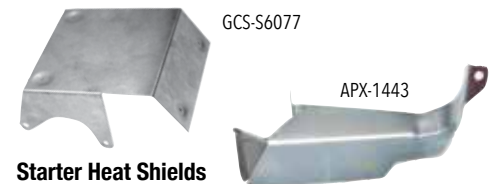

GCS-S6077

APX-1443

Starter Heat Shields

APX-1443 All BB Correct OE Style34.95 ea.

GCS-S6077 Satin Aluminum Universal17.99 ea.

Note: May require some custom fitting. May not clear larger starters.



TUF-6550B

Tuff Stuff Gear Reduction Starters

These gear reduction starters have less draw than traditional replacement starters and crank over engines with higher compression. These starters will work on both Small Block/Big Block Engines using 153 or 168 tooth flywheels. Check your flywheel tooth count before ordering.

TUF-6550B	1.6 H.P., 11:1 Comp, White Zinc.....	143.99 ea.
TUF-6550A	1.6 H.P., 11:1 Comp, Chrome.....	183.99 ea.
TUF-6584B	1.9 H.P., 12:1 Comp, Black.....	139.99 ea.
TUF-6772B	2.6 H.P., 18:1 Comp, Black.....	177.99 ea.
TUF-3193NB	3 H.P., 18:1 Comp, White Zinc.....	175.99 ea.
TUF-3510A	1.9 H.P., 18:1 Comp, Chrome*.....	167.99 ea.
TUF-3510B	1.9 H.P., 18:1 Comp, Black*.....	124.99 ea.

*Offset mounting bolts, 168 tooth flywheel only.



Holley Pump To Carb Lines - Original

Correct reproductions of the original Holley fuel pump to carb lines complete with lines and fuel blocks. These lines are for factory Holleys with 5/16" inlet nuts. These lines will only work on stock engines.

	OM	SS
FPC6775	1968 396/375 HP.....	49.99 ea. 59.99 ea.
FPC6975	1969 396/375 HP.....	49.99 ea. 59.99 ea.
PCY03	5/16" Inlets, 9-3/8" Center to Center.....	36.99 ea. 41.99 ea.

Add "SS" to end of part number when ordering stainless.



Carburetor Inlet Fittings

Correct inlet nuts with washers.

AHL-516	5/16" (Stock GM).....	12.99 ea.
AHL-38	3/8".....	12.99 ea.

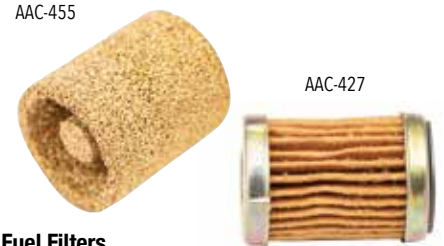

Fuel Filters

Original GM AC Delco

AAC-427	Q-Jet Short Style.....	4.95 ea.
AAC-455	All Holley Brass.....	5.99 ea.



ASM-10A



Starter Motor

We carry original AC Delco USA remanufactured starter motors complete with warranty. No core charge.

ASM-10A	1964-72 SB Auto.....	113.99 ea.
ASM-10M	1964-72 SB Manual.....	113.95 ea.
ASM-20A	1965-72 BB Auto.....	102.95 ea.
ASM-20M	1965-72 BB Manual.....	102.99 ea.

No Volume Discount.

BV-2070



BV-2072



BV-2074



Starter Motor Bolts OEM

Correct "Knurled" bolts for attaching starter motor to block.

BV-2070	SB 3/8-16 x 1-7/8" (short).....	5.99 ea.
BV-2072	BB 3/8-16 x 3-5/8" (long).....	5.99 ea.
BV-2074	3/8-16 x 4-11/16" (x-long).....	5.99 ea.

ATE-4353



Starter Motor Brace

Correct brace for attaching starter to block.

ATE-4353	1964-72 SB w/o 350.....	11.95 ea.
ATW-2516	1964-72 SB 350.....	8.95 ea.
ABB-9655	1964-72 All BB.....	12.99 ea.
APO-516	Attaching Screw.....	0.50 ea.



Fuel Pump to Carburetor Parts

Correct Y blocks and T blocks for your dual feed Holley carburetor.

PCY01	Y Block w/o Bracket, Brass.....	19.99 ea.
PCY02	Y Block w/ Bracket, Brass.....	28.99 ea.
BPS-7432	Stud for PCY02.....	3.95 ea.
RSBB06	Y Block w/ 3/8" Ports, Used for PCY05.....	24.99 ea.

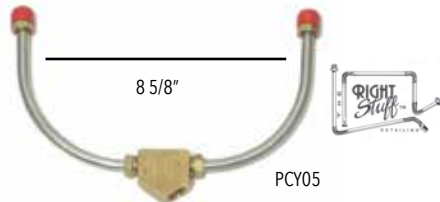

Holley Pump To Carb Lines - Replacement

Now you can add a new Holley dual feed carburetor without having to change the 3/8" inlet nuts! This new kit comes complete with pre-bent lines and a new 3/8" brass Y block.

	OM	SS
PCY05	3/8" inlets, 8-5/8" Center to Center.....	30.99 ea. 36.99 ea.
PCY07	3/8" inlets, 9-3/8" Center to Center.....	30.99 ea. 36.99 ea.

BUY'N SAVE WITH KITS



GF-432 Fuel Filter & Bracket

This is an OE style reproduction of the original GF-432 fuel filter and bracket for use with 3 piece fuel line. Buy the kit and save!

GF-432K	1969 GF-432 Complete.....	50.31 kit
AAC-432	1969 GF-432 Filter.....	39.95 ea.
AFB-234	1969 GF-432 Bracket.....	15.95 ea.



1969 Nova 350 & 396 3 Piece Line Sets

These unique lines are for use with cars equipped with the GF-432 canister filter and bracket.

	OM	SS
FPC6905	1969 350.....	36.99 ea. 46.99 ea.
FPC6903	1969 396/325.....	36.99 ea. 46.99 ea.
FPC6903	1969 396/350.....	36.99 ea. 46.99 ea.



AFP-1021

Fuel Pump

Original replacement fuel pumps. Brand new AC-Delco units "gold anodized" as original.

AFP-1115	1964-66 283.....	41.95 ea.
AFP-1116	1964-68 327, 350 5/16".....	69.95 ea.
AFP-1021	1968-72 All SB 3/8".....	41.95 ea.
AFP-1121	1967-72 All BB 3/8".....	44.99 ea.
AFP-1124	1968-72 All BB w/ Return.....	51.95 ea.

AFP-40727



Delco Logo Fuel Pump

New reproduction fuel pump features the large AC Delco logo. This fuel pump is a must when restoring your car to factory stock.

AFP-40727	1967-72 GM #40727.....	65.95 ea.
AFP-40963	1970-72 GM #40963.....	65.95 ea.

Note: AFP-40963 has return.

Holley Chrome Fuel Pumps

HOL-12834

Mechanical pumps designed to work with stock or mildly modified engines.

Free-flow output of 80 GPH (SB) or 80-130 GPH (BB). Body castings can be rotated 360-degrees to ease mounting in difficult places. Heavy duty construction can withstand long periods at high RPM. 1/4" (SB) 3/8" (BB) pipe thread inlet and outlet ports.



HOL-12834	Small Block.....	93.99 ea.
HOL-12835	Big Block.....	93.99 ea.

Note: Not compatible with methanol or alcohol. Cannot be used with fuel injection systems.



QF-30-350QFT



Quick Fuel Technology Fuel Pumps

For the street cruiser, it's tough to beat the simplicity and reliability of a mechanical fuel pump. Quick Fuel Technology's mechanical pumps flow 110 gallons per hour and utilize lightweight aluminum housings. They feature integrated shutoff valves that are preset at 6.5- to 8 psi, eliminating the need for a separate pressure regulator. For added installation flexibility, the pump casting can be rotated to accommodate various plumbing configurations. 3/8" NPT threads. Gasoline only.

QF-30-350QFT	Small Block.....	101.99 ea.
QF-30-454QFT	Big Block.....	110.99 ea.

No volume discount.



QF-30-125-1QFT



Quick Fuel Technology Electric Fuel Pumps

QFT's electric fuel pumps are perfect for combinations that are neither stock nor all out race cars. These pumps flow more than enough fuel to support between 400-750 hp. Mounting hardware and brackets are included.

- 125 GPH Flow Rate
- 14 PSI Maximum Pressure
- Features 3/8" NPT Inlets and Outlets
- Draws 4 Amps or Less at Full Load
- For Carbureted Gasoline Applications Only

QF-30-125-1QFT	Pump Only.....	117.99 ea.
----------------	----------------	------------

QF-30-125-1RQFT	Pump/Regulator.....	134.99 ea.
-----------------	---------------------	------------

No volume discount.



HOL-12-426

Holley Electric Fuel Pumps

Holley is proud to introduce the all new Holley Mighty Mite™ electric fuel pumps! They're big on performance, but small in size! They're quiet, easy to install and work with gas, diesel, blended alcohol and E85!

12 volt operation, 25 gal/hr flow, Good for up to 300HP naturally aspirated. Simple 2 wire hookup. Self-priming and regulating. Quiet operation - 65db, Hose barbs Fit 5/16" Fuel Hose, Made in the USA

HOL-12-426	All 25 GPH 1.5-4 PSI.....	50.99 ea.
HOL-12-427	All 32 GPH 4-7 PSI.....	50.99 ea.

No volume discount.



HOL-12-803BP

Holley Fuel Pressure Regulator

Holley fuel pressure regulators are designed to precisely control the fuel pressure from the fuel pump to the carburetor. Too much fuel pressure for a given needle and seat assembly will overload and may cause flooding or drivability problems. Each Holley fuel pressure regulator is fully adjustable so regulating the fuel pressure to your engine's needs is simple.

12 volt operation, Preset to 7psi, 3/8" NPT ports (1 in, 1 out, 1 bypass or return), Used in systems with a return line back to the fuel tank

HOL-12-803BP	All Carbureted.....	88.99 ea.
--------------	---------------------	-----------

No volume discount.

GCS-S5461BK



LS Billet Fuel Rail Kits

Black anodized billet aluminum fuel rails add a nice custom touch to your LS swap.

GCS-S5461BK	LS1.....	140.99 kit
GCS-S5462BK	LS2.....	140.99 kit
GCS-S5463BK	LS3.....	140.99 kit



GCS-S4297

GCS-S9245

GCS-S9407

GCS-S9177

Chrome Inline Fuel Filters

Choose from a variety of show quality chrome fuel filters to dress up your engine.

Carburetor

GCS-S9407	Bronze Element, 3/8", Chrome.....	10.99 ea.
GCS-S9177	Paper Element, 3/8", Chrome.....	7.99 ea.
GCS-S9177BK	Paper Element, 3/8", Black.....	7.99 kit
GCS-S9245	Glass Element, 3/8", Chrome.....	10.99 ea.
GCS-S9212BK	Paper Element, 5/16", Black.....	7.99 ea.

Red Top High Capacity Chrome Fuel Filters

Show quality chrome plated fuel filter with paper element and pipe fittings.

GCS-S4297	Small.....	39.99 ea.
GCS-S4295	Large.....	39.99 ea.

AJE-395



ACE-4867

ACE-9599

Fuel Pump Hardware

AJE-395	All Activating Rod.....	14.95 ea.
ACE-9599	All SB Plate.....	10.99 ea.
ACE-4867	Fuel Pump Bolts.....	7.95 kit



AXP-3800

AXP-6400

Fuel Pump Hose Kit

Correct GM hose for connecting fuel pump to main fuel line. Complete with correct "colored" pinch clamps.

AXP-3800	All 3/8" 3pc.....	4.95 kit
AXP-1438	All 3/8"-1/4" 6pc.....	6.95 kit
AXP-6400	All 3/8" 90 Degree Bend.....	11.95 kit



AFT-238

Fuel Line Brace

Correct factory installed brace for carb line.

AFT-238	1970 L-78, LS-6.....	15.95 ea.
---------	----------------------	-----------