

**SUSPENSION & RELATED**

**VELOCITY SERIES SUSPENSION**

Why own a muscle car you hate to drive? A great suspension is the key to a great driving car. That is why Ground Up created our Velocity Series Suspension Kits. Our Velocity line of suspensions offer you the chance to update and upgrade your suspension while maintaining your budget. Whether you are looking for an upgraded system, a stock replacement system or just a basic budget friendly system, Ground Up has you covered.



DIX-70V

**BUY'N SAVE**  
WITH KITS



**Deluxe OEM Front Suspension Kit**  
This is the ultimate suspension kit! Each kit includes the finest quality OEM components. Be sure to check which type of lower control arm bushings you have.

- 2 Upper Ball Joints
- 4 Lower Control Arm Bushings
- 2 Lower Ball Joints
- 4 Upper Control Arm Bushings
- 2 Outer Tie Rods
- 2 Stabilizer Ends Links
- 2 Inner Tie Rods
- 2 Adjuster Sleeves
- 1 Idler Arm

DIX-64	1964-67 Regular Bushings 13/16" Idler Arm.....	321.39 kit
DIX-64B	1964-67 Large 1.90" Bushings 13/16" Idler Arm.....	324.79 kit
DIX-64B78	1964-67 Regular Bushings 7/8" Idler Arm.....	321.39 kit
DIX-64B78	1964-67 Large 1.90" Bushings 7/8" Idler Arm.....	324.79 kit
DIX-70	1968-70 w/ Round Bushings.....	321.39 kit
DIX-70V	1968-70 w/ Oval Bushings.....	333.29 kit
DIX-72	1971-72 w/ Round Bushings.....	372.39 kit
DIX-72V	1971-72 w/ Oval Bushings.....	384.29 kit

*No Volume Discount.*



E-DIX64



**Value Front Suspension Kit**  
This kit is perfect for your daily driver or restoration on a budget. It includes all high quality imported suspension parts.

- 2 Upper Ball Joints
- 2 Outer Tie Rods
- 2 Lower Ball Joints
- 2 Inner Tie Rods
- 4 Lower Control Arm Bushings
- 2 Stabilizer Ends Links
- 4 Upper Control Arm Bushings
- 2 Adjuster Sleeves
- 2 Sway Bar Bushings

E-DIX64	1966-72 Regular Bushings.....	183.69 kit
E-DIX64B	1964-66 Large 1.90" Bushings.....	185.39 kit
E-DIX70V	1968-72 Oval Bushings.....	185.39 kit
E-DIX-70	1968-72 Round Bushings.....	183.69 kit

*No Volume Discount.*





**Polygraphite Basic Front End Rebuild Kit**  
Polygraphite bushings used in this kit are the ultimate combination of polyurethane and graphite. You get performance and durability with superior lubricating qualities which provides smooth operation. Kits include upper and lower ball joints, outer tie rods, control arm bushing kit and lower bump stops.

6465FK-P	1964-65.....	250.80 kit
66FK-P	1966.....	236.87 kit
6770FK-PM	1967-70.....	236.87 kit
7172FK-P	1971-72.....	243.54 kit

*No Volume Discount.*





**Polygraphite Deluxe Front End Rebuild Kit**  
For the ultimate in performance, install our polygraphite front end kit featuring Energy Suspension parts! This kit offers increased longevity and better performance than the stock rubber front end components. Kits include upper and lower ball joints, inner and outer tie rods, tie rod adjusting sleeves, idler arm bushings and control arm bushing kit and bump stops.

64SFK-P7	1964 w/ 7/8" Idler Arm.....	350.56 kit
64SFK-P13	1964 w/ 13/16" Idler Arm.....	350.56 kit
65SFK-P	1965 w/ 7/8" Idler Arm.....	350.56 kit
66SFK-P	1966 w/ 7/8" Idler Arm.....	350.56 kit
67SFK-PM	1967 w/ 7/8" Idler Arm.....	350.56 kit
6870SFK-P	1968-70.....	371.18 kit
7172SFK-PM	1971-72.....	401.56 kit

*End link kit sold separately. No Volume Discount.*



DSE031309



DSE031317



**DSE Pro Touring Front Speed Kit 1**

This exclusive DSE Speed Kit is a complete bolt-on suspension upgrade system designed for ease of installation with no modification to frame. This kit includes:

- Tubular Upper & Lower Control Arms
- Forged 2" Drop Spindles
- Koni Classic Shocks
- Coil Springs
- Tubular Sway Bar Kit

DSE031309	1964-66 SB or LS .....	2649.99 kit
DSE031312	1964-66 BB .....	2649.99 kit
DSE031310	1967 SB or LS .....	2649.99 kit
DSE031313	1967 BB.....	2649.99 kit
DSE031311	1968-72 SB or LS .....	2649.99 kit
DSE031314	1968-72 BB .....	2649.99 kit
DSE031333	1978-88 SB or LS .....	2299.99 kit

*When using stock disc brakes, the stock caliper brackets will have to be notched out slightly to fit the DSE spindles. On 1964-67 models, the existing sway bar mounting holes will need to be drilled and tapped to 3/8". Ships Oversized. Not eligible for free shipping. No Volume Discount.*

**DSE Pro Touring Front Speed Kit 2**

Speed Kit 2 improves the handling and performance to the next level and offers ride height adjustment. This kit includes:

- Tubular Upper & Lower Control Arms
- Forged 2" Drop Spindles
- DSE Aluminum Body Shocks
- Coilover Springs
- Tubular Sway Bar Kit

DSE031317	1964-66 SB or LS .....	2974.99 kit
DSE031319	1964-66 BB .....	2974.99 kit
DSE031318	1967-72 SB or LS .....	2974.99 kit
DSE031320	1967-72 BB .....	2974.99 kit
DSE031335	1978-88 BB .....	2724.99 kit

*When using stock disc brakes, the stock caliper brackets will have to be notched out slightly to fit the DSE spindles. On 1964-67 models, the existing sway bar mounting holes will need to be drilled and tapped to 3/8". Ships Oversized. Not eligible for free shipping. No Volume Discount.*



ES-681

**Inner Tie Rods**

Correct OE style cast steel inner tie rods with correct grease fit locations. The highest quality original style suspension products on the market!

ES-681	1964-70 LH/RH .....	29.95 ea.
ES-406L	1971-72 LH/RH .....	45.95 ea.
ES-2034	1978-88 LH/RH .....	23.95 ea.



ES-333

**Outer Tie Rods**

Correct OE style cast steel outer tie rods with correct grease fit locations. The highest quality original style suspension products on the market! Fits LH or RH.

ES-333	1964-70 .....	34.95 ea.
ES-406R	1971-72 .....	45.95 ea.
ES-2033	1978-88 .....	23.95 ea.



DS-749

**Center Drag Links**

DS-740R	1964-66 13/16" .....	119.95 ea.
DS-740	1964-67 7/8" .....	114.95 ea.
DS-749	1968-72 All .....	49.95 ea.

No Volume Discount.



BPX-9873

D-18634

**Idle Arms**

D-18633	1964-67 7/8" .....	49.95 ea.
D-18634	1964-67 13/16" .....	49.95 ea.
D-18634	1968-72 13/16" .....	49.95 ea.
D-6187	1978-88 All .....	36.95 ea.
BPX-9873	Bolts .....	3.95 pr.



FA-487

FA-993

DRVT-33

**Ball Joints**

FA-487	1964-72 All Upper .....	22.95 ea.
FA-993	1964-72 All Lower .....	22.95 ea.
FA-688	1978-88 Upper .....	26.95 ea.
FA-921	1978-88 Lower .....	26.95 ea.
DRVT-33	Ball Joint Rivets (8 pc.) .....	30.99 kit



ES-2032

**Adjustment Sleeves**

OEM style adjustment sleeve for proper adjustment of tie rods.

ES-2032	1964-70 LH/RH .....	11.95 ea.
ES-2004	1971-72 LH/RH .....	14.95 ea.
ES-2032S	1978-88 LH/RH .....	10.95 ea.



**DSE Tubular Adjustment Sleeves**

Tubular tie rod adjusters improve the strength and integrity of your steering system over stock. The tubular design is stiffer than the OEM split clamp adjuster and weighs less.

DSE090103B	1964-70 Black.....	72.99 kit
DSE090102B	1971-77 Black.....	72.99 kit

No Volume Discount.



**UMI Tie Rod Adjusters**

These heavy duty tie rod adjusters from UMI Performance are designed to eliminate the factory clamp style design making adjustments easy and hassle free while adding enhanced steering. Works with the factory tie rod ends.

UMI-2103HD	1964-70 Billet.....	64.99 kit
UMI-2103	1964-70 Mild Steel.....	54.99 kit
UMI-2104HD	1971-72 Billet.....	64.99 kit
UMI-2104	1971-72 Mild Steel.....	54.99 kit
UMI-2103HD	1978-88 Billet.....	64.99 kit
UMI-2103	1978-88 Mild Steel.....	54.99 kit

## PERFORMANCE HANDLING KITS



UMI-ABF401-1-B

### UMI Performance Stage 1 Handling Kit

This inexpensive kit offers great ride quality and improved handling while giving your muscle car the stance you want. Available in a durable red or black powder coat finish. Springs are black and shocks are red.

Insert color choice in \_\_\_ R = Red ..... B = Black  
**Stage 1 Handling Kits**

UMI-ABF401-0-__	1964-66 Stock Height .....	1229.99 kit
UMI-ABF401-1-__	1964-66 1" Drop .....	1229.99 kit
UMI-ABF401-2-B	1964-66 2" Drop .....	1229.99 ea.
UMI-ABF401-67-0-__	1967 Stock Height .....	1229.99 kit
UMI-ABF401-67-1-__	1967 1" Drop .....	1229.99 kit
UMI-ABF401-67-2-__	1967 2" Drop .....	1229.99 kit
UMI-ABF801-0-__	1968-72 Stock Height .....	1229.99 kit
UMI-ABF801-1-__	1968-72 1" Drop .....	1229.99 kit
UMI-ABF801-2-__	1968-72 2" Drop .....	1229.99 kit

### Stage 1.5 Handling Kits

w/ upgraded adjustable shocks.

UMI-ABF415-1-__	1964-66 1" Drop .....	1699.95 kit
UMI-ABF415-2-__	1964-66 2" Drop .....	1699.95 kit
UMI-ABF415-67-1-__	1967 1" Drop .....	1749.99 kit
UMI-ABF415-67-2-__	1967 2" Drop .....	1699.95 kit
UMI-ABF815-1-__	1968-72 1" Drop .....	1699.95 kit
UMI-ABF815-2-__	1968-72 2" Drop .....	1699.95 kit

*Ships Oversize. No Volume Discount.*



UMI-ABF403-64-1-R

### UMI Performance Stage 2 Handling Kit

Includes everything needed to rebuild the suspension on your classic 1964-1972 GM A-Body. This kit will make any classic cruiser feel like a modern day muscle car!

Stage 2 Kit Includes:

- Tubular upper and lower front A-arms
- Heavy Duty Sway bars with bushings and end links
- Set of (4) UMI S series performance monotube shocks
- 1" or 2" premium UMI lowering springs
- Tubular upper and lower rear control arms
- Tubular frame braces
- Replacement rear end housing bushings
- All new Grade 8 hardware and lock nuts

Insert color choice in \_\_\_ R = Red ..... B = Black

UMI-ABF403-64-1-__	1964, 1" Lowering .....	2979.99 kit
UMI-ABF403-1-__	1965-66, 1" Lowering .....	2979.99 kit
UMI-ABF403-67-1-__	1967, 1" Lowering .....	2979.99 kit
UMI-ABF403-67-2-__	1967, 2" Lowering .....	2979.99 kit
UMI-ABF803-1-__	1968-72, 1" Lowering .....	2979.99 kit
UMI-ABF803-2-__	1968-72, 2" Lowering .....	2979.99 kit

*Ships Oversize. No Volume Discount.*



UMI-ABF405-67-1-R

### UMI Performance Stage 3 Handling Kit

UMI's Stage 3 kit has been made with great street manners combined with Pro-Touring handling capability. In this newest revision we've refined our parts list to provide the most common options in one convenient package.

Insert color choice in \_\_\_ R = Red ..... B = Black  
**Stage 3 Handling Kits**

w/ Standard 1" bolt-in rear sway bar & non-adjustable Ridetech shocks.

UMI-ABF405-64-1-__	1964, 1" Lowering .....	3269.99 kit
UMI-ABF405-1-__	1965-66, 1" Lowering .....	3269.99 kit
UMI-ABF405-67-1-__	1967, 1" Lowering .....	3269.99 kit
UMI-ABF405-67-2-__	1967, 2" Lowering .....	3269.99 kit
UMI-ABF805-1-__	1968-72, 1" Lowering .....	3269.99 kit
UMI-ABF805-2-__	1968-72, 2" Lowering .....	3269.99 kit

### Stage 3.5 Handling Kits

w/ Pro-touring 1" chassis mount rear sway bar & Ridetech 8-way rebound adjustable shocks.

UMI-ABF406-64-1-__	1964, 1" Lowering .....	3959.99 kit
UMI-ABF406-1-__	1965-66, 1" Lowering .....	3959.99 kit
UMI-ABF406-67-1-__	1967, 1" Lowering .....	3959.99 kit
UMI-ABF406-67-2-__	1967, 2" Lowering .....	3959.99 kit
UMI-ABF806-1-__	1968-72, 1" Lowering .....	3959.99 kit
UMI-ABF806-2-__	1968-72, 2" Lowering .....	3959.99 kit

*Ships Oversize. No Volume Discount.*



UMI-ABF407-64-1-R

### UMI Performance Stage 4 Handling Kit

Who says you can't have it all? UMI's Stage 4 kit transforms your A-Body into a handling machine with the adjustability to perform well at the strip or haul your family comfortably - to the autocross.

#### Front Spring Rate Options:

- 450lb- Small block cruise
- 550lb- Small block handling, all big blocks

Insert color choice in \_\_\_ R = Red ..... B = Black

**450 lb. Front Spring Rate, 1" Rear Drop**

UMI-ABF407-64-1-__	1964 .....	3899.99 kit
UMI-ABF407-1-__	1965-66 .....	3899.99 kit
UMI-ABF407-67-1-__	1967 .....	3899.99 kit
UMI-ABF807-1-__	1968-72 .....	3899.99 kit

**550 lb. Front Spring Rate, 1" Rear Drop**

UMI-ABF408-64-1-__	1964 .....	3899.99 kit
UMI-ABF408-1-__	1965-66 .....	3899.99 kit
UMI-ABF408-67-1-__	1967 .....	3899.99 kit
UMI-ABF808-1-__	1968-72 .....	3899.99 kit

**450 lb. Front Spring Rate, 2" Rear Drop**

UMI-ABF407-64-2-__	1964 .....	3899.99 kit
UMI-ABF407-2-__	1965-66 .....	3899.99 kit
UMI-ABF407-67-2-__	1967 .....	3899.99 kit
UMI-ABF807-2-__	1968-72 .....	3899.99 kit

**550 lb. Front Spring Rate, 2" Rear Drop**

UMI-ABF408-64-2-__	1964 .....	3899.99 kit
UMI-ABF408-2-__	1965-66 .....	3899.99 kit
UMI-ABF408-67-2-__	1967 .....	3899.99 kit
UMI-ABF808-2-__	1968-72 .....	3899.99 kit

*Ships Oversize. No Volume Discount.*



UMI-ABF409-6-1-R

### UMI Performance Stage 5 Handling Kit

UMI's new Stage 5 kit includes all of our high-end Pro-Touring products and will turn your A-Body into a corner carving machine.

Insert color choice in \_\_\_ R = Red ..... B = Black

**450 lb. Front Spring Rate, 1" Rear Drop**

UMI-ABF409-1-__	1965-66 .....	4169.99 kit
UMI-ABF409-1-67-__	1967 .....	3979.95 kit
UMI-ABF809-1-__	1968-72 .....	4169.99 kit

**550 lb. Front Spring Rate, 1" Rear Drop**

UMI-ABF410-1-__	1965-66 .....	4169.99 kit
UMI-ABF410-1-67-__	1967 .....	3979.95 kit
UMI-ABF810-1-__	1968-72 .....	4169.99 kit

**450 lb. Front Spring Rate, 2" Rear Drop**

UMI-ABF409-2-__	1965-66 .....	4169.99 kit
UMI-ABF409-2-67-__	1967 .....	3979.95 kit
UMI-ABF809-2-__	1968-72 .....	4169.99 kit

**550 lb. Front Spring Rate, 2" Rear Drop**

UMI-ABF410-2-__	1965-66 .....	4169.99 kit
UMI-ABF410-2-67-__	1967 .....	3979.95 kit
UMI-ABF810-2-__	1968-72 .....	4169.99 kit

*Ships Oversize. No Volume Discount.*



UMI-406503-B

### UMI Corner Max Handling Kit

UMI's Corner Max front end kits are a comprehensive system with our best corner carving parts under one easy to find part number. The Corner Max system combines geometry corrected a-arms with tall ball joints, higher rate springs, UMI rebound adjustable monotube shocks, heavy duty sway bar and a bump steer kit. The foundation of the kit includes our coilover-only lower a-arms featuring caster improvement, tall ball joints and the ability to remove the spring and shock without taking the spindle apart. The upper a-arm features rod ends for smooth operation and the ability to adjust without shims. The 1-5/16th inch sway bar upgrade complete with UMI's fabricated end links reduces body roll and helps speed transitions. Racing coilover springs are paired with UMI's rebound adjustable coilover monotube shocks. Fine tuning is accomplished with a UMI bump steer kit.

Insert color choice in \_\_\_ R = Red ..... B = Black

**Kits That Reuse Factory Spindles**

UMI-406401-__	1964-67 .....	2699.99 kit
UMI-406402-__	1968-70 .....	2699.99 kit
UMI-406403-__	1971-72 .....	2699.99 kit

**Kits That Come With Taller 2" Drop Spindles**

UMI-406501-__	1964-67 .....	3069.99 kit
UMI-406502-__	1968-70 .....	3069.99 kit
UMI-406503-__	1971-72 .....	3069.99 kit

*No Volume Discount.*



**TUBULAR CONTROL ARMS**

**Tubular Control Arm and Forged Spindle Kit**

The DSE spindle is 1-1/2 inches taller than the stock Chevelle spindle and provides 2 inches of drop from stock height. The taller spindle height improves handling by modifying the camber curve resulting in a negative camber gain during suspension compression. The stock steering arms mount in the optimal location to minimize bump steer. Detroit Speed's tubular upper control arms provide increased strength and additional positive caster. DSE's lower tubular control arms feature a robust tubular design with gussets and a cross brace. Uppers and lowers feature five axis laser cut tube ends and ball joint pockets for a precise fit.

- DSE030104 1964-66 All ..... 1949.99 kit
- DSE030105 1967-72 All ..... 1949.99 kit

*Installation should be followed by a professional alignment.*

*When using stock disc brakes, the stock caliper brackets will have to be notched out slightly to fit the DSE spindles. Ships Oversized. Not eligible for free shipping. No Volume Discount.*



**DSE Camber/Caster Kit**

This kit allows you to adjust camber easily with our one-piece slotted camber shims. Each shim is machined from 6061 aluminum and is then anodized black for durability. Includes four 1/16" shims, four 1/8" shims and two 1/4" shims.

- DSE031715 1973-77 ..... 98.99 kit
- DSE031721 1978-88 ..... 93.99 kit



**Economy Tubular Control Arms. Upper/Lower, Black Set**

UCA6472-KIT

Economy upper and lower control arms come complete with ball joints and cross shafts and sway bar endlinks. Improve your front suspension with increased caster built into the arm. Arms are made from large diameter DOM tubing. These specially made arms are designed to fix camber angle problems caused from using drop spindles or drop coils. This set is for the budget minded guy looking to install a set of upper and lower tubular arms with out breaking the bank.

- UCA6472-KIT 1964-72 ..... 441.92 kit

**UMI Upper & Lower Tubular A-Arms**

Improve the street and track performance of your A-Body and achieve that precise Pro-Touring feel by adding a set of fabricated tubular A-Arms. The stock geometry lower a-arms, which work with most popular springs and coil-overs, feature tough tubular construction with greasable polyurethane bushings for precise handling and smooth suspension motion. Optional Delrin® bushings offer additional precision and decreased friction. The ball joint mount is angled slightly from stock to permit usage with lowered vehicles and the design offers additional wheel clearance. The tubular upper a-arms feature Delrin® bushings as well as billet chromoly cross shafts. The relocated ball joint mounting pad increases caster, steering feel and stability without excessive shims and can be loaded with 1/2" taller upper ball joints to improve camber performance. The ultra tough red or black powder coat finish guarantees your performance parts stay looking new. Included with each kit are recommended alignment specs along with detailed installation instructions. Insert color choice in \_\_, R = Red B = Black

**Lower A-Arms w/ Polyurethane Bushings Upper Lower Kits**

- UMI-403133-\_\_ 1964-72 Standard Ball Joints ..... 1149.99 kit
- UMI-403133-1-\_\_ 1964-72 0.5" Taller Upper Ball Joints ..... 1229.99 kit
- UMI-303133-\_\_ 1978-88 Standard Ball Joints ..... 1149.99 kit
- UMI-303133-1-\_\_ 1978-88 0.5" Taller Ball Joints ..... 1229.99 kit

**Lower A-Arms w/ Delrin® Bushings Upper Kits**

- UMI-403233-\_\_ 1964-72 Standard Ball Joints ..... 1219.99 kit
- UMI-403233-1-\_\_ 1964-72 0.5" Taller Upper Ball Joints ..... 1299.99 kit
- UMI-303233-\_\_ 1978-88 Standard Ball Joints ..... 1219.99 kit
- UMI-303233-1-\_\_ 1978-88 0.5" Taller Ball Joints ..... 1299.99 kit

**Upper Arms Only**

- UMI-4033-\_\_ 1964-72 Tubular Upper Non/Adjustable Standard Ball Joint ..... 519.99 pr.
- UMI-4033-1-\_\_ 1964-72 Tubular Upper Non/Adjustable .5" Taller Ball Joint ..... 599.99 pr.
- UMI-4056-1-\_\_ 1964-72 Tubular Upper Adjustable Standard Ball Joint ..... 519.99 pr.
- UMI-4056-2-\_\_ 1964-72 Tubular Upper Adjustable .5" Taller Ball Joint ..... 599.99 pr.
- UMI-4056-3-\_\_ 1964-72 Tubular Upper Adjustable .5" Taller Ball Joint ..... 629.99 pr.
- UMI-3033-\_\_ 1978-88 Tubular Upper Non/Adjustable Standard Ball Joint ..... 519.99 pr.
- UMI-3033-1-\_\_ 1978-88 Tubular Upper Non/Adjustable .5" Taller Ball Joint ..... 599.99 pr.
- UMI-3056-1-\_\_ 1978-88 Tubular Upper Adjustable Standard Ball Joint ..... 519.99 pr.
- UMI-3056-2-\_\_ 1978-88 Tubular Upper Adjustable 0.5" Taller Ball Joint ..... 599.99 pr.
- UMI-3056-1-\_\_ 1978-88 Tubular Upper Adjustable 1" Taller Ball Joint ..... 519.99 pr.

**Lower Arms Only**

- UMI-4031-\_\_ 1964-72 Tubular Lower Poly Bushings Standard Ball Joint ..... 629.99 pr.
- UMI-4032-\_\_ 1964-72 Tubular Lower Delrin Bushings Standard Ball Joint ..... 699.99 pr.
- UMI-4032-1-\_\_ 1964-72 Tubular Lower Delrin Bushings .5" Taller Ball Joint ..... 779.99 pr.
- UMI-3031-\_\_ 1978-88 Tubular Lower Poly Bushings Standard Ball Joint ..... 629.99 pr.
- UMI-3031-1-\_\_ 1978-88 Tubular Lower Poly Bushings .5" Taller Ball Joint ..... 599.99 pr.
- UMI-3032-\_\_ 1978-88 Tubular Lower Delrin Bushings Standard Ball Joint ..... 699.99 pr.
- UMI-3032-1-\_\_ 1978-88 Tubular Lower Delrin Bushings .5" Taller Ball Joint ..... 779.99 pr.

*Tall Ball Joint Option: UMI is proud to offer a number of tall ball joint options. In addition to standard height ball joints, we offer 0.5" tall lower and both 0.5" and 0.9" tall upper. Additional ball joint height functions the same as adding a taller spindle at a fraction of the cost. Drag and cruising oriented cars work fine with standard height while tall ball joints optimize cornering ability. No Volume Discount. Not eligible for free shipping.*



UMI-403133-R



UMI-403133-B



UMI-4054

**Coilover Conversion Brackets**

- UMI-4054 1964-72 Front Coilover Conversion Brackets, Weld-in..... 199.95 ea.

**FRONT SWAY BARS & RELATED**



**OEM Front Sway Bar Kit**

Eliminate poor handling by installing one of these sway bars!  
It includes sway bar, brackets, bushings and end links to replace your old, small bar.

DAA-324	1964-77 1-1/4" Kit.....	178.07 kit
DAA-525	1964-77 1-1/8" Kit.....	155.48 kit
DAA-9SS	1 1/8" Sway Bar only.....	129.95 ea.
DAA-8A	1.25" Sway Bar only.....	159.95 ea.
DAA-898	1978-88 1-1/8" Kit.....	149.95 kit

No Volume Discount. Ships Oversize 2. Not eligible for free shipping.



**1964-77 Energy Suspension Sway Bar Kits**

Do you want to find an easy way to improve poor handling? This complete Chevelle sway bar kit allows you to lose that small diameter front sway bar and replace it with a large diameter sway bar and all of the necessary components in one shot!

ENG-6472-118-KITB	1-1/8" Black Bushings.....	156.54 kit
ENG-6472-118-KITR	1-1/8" Red Bushings.....	156.54 kit
ENG-6472-114-KITB	1-1/4" Black Bushings.....	173.34 kit
ENG-6472-114-KITR	1-1/4" Red Bushings.....	173.34 kit

No Volume Discount. Ships Oversize 2. Not eligible for free shipping.



UMI-403534-R

**UMI Front & Rear Sway Bars**

UMI Performance Chevelle solid sway bars are designed to reduce body roll, understeer and increase cornering capabilities resulting in a more balanced suspension. UMI Performance sway bars are manufactured from 4140 chrome moly steel and formed as one piece to ensure maximum strength and performance. The rear sway bar is heat treated to maintain longer memory than a cold bent sway bar. The front sway bar is CNC bent for a precision fit. Comes with poly end links and bushings. Available powder coated bright red or gloss black for a durable long lasting finish. Insert your color choice at the end of the part number in \_\_. R = Red B = Black

**Front & Rear Kit**

UMI-403534-__	1964-72 Front 1-1/4" Rear 1".....	369.99 kit
UMI-303534-__	1978-88 Front 1-1/4" Rear 1".....	369.99 kit

**Front OE Style Mounts**

UMI-4035-__	1964-72 1-1/4" Bar.....	209.99 kit
UMI-4067-__	1964-77 Front 1-5/16" Bar.....	229.95 kit
UMI-3035-__	1978-88 1-1/4" Bar.....	209.99 ea.

**Front Billet Style Mounts**

UMI-4066-__	1964-77 Front 1-5/16" Bar.....	344.95 kit
-------------	--------------------------------	------------

**Rear OE Style Mounts**

UMI-4034-__	1964-72 1" Bar.....	159.95 kit
UMI-3034-__	1978-88 1" Bar.....	159.95 ea.

**Rear Chassis Style Mounts**

UMI-4047-300-__	1964-72 1" Bar 3" Axle.....	449.99 kit
UMI-4047-300-__	1964-72 1" Bar 3" Axle.....	449.99 kit
UMI-3044-275-__	1978-88 1" Bar 2 3/4" Axle.....	449.99 ea.
UMI-3044-300-__	1978-88 1" Bar 3" Axle.....	449.99 ea.
UMI-3045-275-__	1978-88 1-3/8" Bar 2 3/4" Axle.....	489.99 ea.
UMI-3045-300-__	1978-88 1-3/8" Bar 3" Axle.....	489.99 ea.

**Front Billet Mounts Only (no bar)**

UMI-90047	1964-77 1-1/4" Red.....	129.95 pr.
UMI-90066	1964-77 1-5/16" Red.....	129.95 set

No Volume Discount. Ships Oversize.

**Stabilizer End Links**

Complete kit for one car.

DSL-72	1964-77 All OEM.....	14.95 kit
9-8118G	1964-77 Polyplus Black Kit.....	21.99 kit
9-8118R	1964-77 Polyplus Red Kit.....	21.99 ea.
DSL-88	1978-88 All OEM.....	14.95 pr.
9-8119G	1978-88 Polyplus Black Kit.....	21.99 kit

DSL-72



**Sway Bar Bushings**

OEM rubber bushings.



DMG-647	1964-67 SB.....	12.95 pr.
DMG-657	1965-68 BB.....	12.95 pr.
DMG-681	1968-72 SB.....	11.95 pr.
DMG-683	1964-77 1-1/16".....	11.95 pr.
DMG-1516	1978-88 1-5/16" w/ Tabs On Bracket.....	15.95 pr.
DMG-1116	1978-88 1-1/16" w/ Tabs On Bracket.....	15.95 pr.
DMG-118	1978-88 1-1/8" w/o Tabs On Bracket.....	17.95 pr.
DMG-1316	1978-88 1-1/8" w/o Tabs On Bracket.....	12.95 pr.

**Sway Bar Brackets**

Correct mounting bracket for stock front sway bar.



DBB-157	1964-77 1-1/16".....	7.95 ea.
BAR-1295	Correct Bolt.....	0.75 ea.
MK52-KIT	1964-72 Brackets/Bushings 1-1/4" (For use with 1 1/4" bar only).....	22.95 kit



**DSE Tubular Front Sway Bar Kit**

DSE's tubular 1-3/8 inch front sway bar kit is designed to address the shortcomings of the small factory A Body sway bar. Includes greasable polyurethane bushings, mounts and end links giving you dramatic improvement over your stock suspension and even better results when you combine this sway bar kit with other DSE suspension components.

DSE031402	1964-72 1-3/8" Tubular.....	274.99 kit
DSE031406	1973-77 1-3/8" Tubular.....	259.99 kit
DSE031408	1978-88 1-3/8" Tubular Includes Braces.....	394.99 kit

On 1964-67 models, the existing sway bar mounting bracket holes will need to be drilled and tapped to 3/8". No Volume Discount. Ships Oversize 2. Not eligible for free shipping.



**DSE Splined Front Sway Bar Kit**

DSE's tubular 1-3/8 inch front sway bar kit is designed to address the shortcomings of the small factory A Body sway bar. Includes greasable polyurethane bushings, mounts and end links giving you dramatic improvement over your stock suspension and even better results when you combine this sway bar kit with other DSE suspension components.

DSE031404	1964-72 1-1/2" Splined.....	939.99 kit
-----------	-----------------------------	------------

On 1964-67 models, the existing sway bar mounting bracket holes will need to be drilled and tapped to 3/8". No Volume Discount. Ships Oversize 2. Not eligible for free shipping.

## BODY BUSHINGS & CHASSIS BRACE



DCC-1516

### Body Mounting Kits

Complete with everything you need to mount your body to the frame including correct rubber bushings with steel inserts and factory style OEM flanged head frame bolts with washers! Remember, your entire body rides on this hardware, so replacing your worn out body bushings and hardware is extremely important not only for looks but for safety!

DCC-1514	1964-67 Coupe/El Camino w/o Rad Support Bushings.....	60.27 kit
DCC-1514RS	1965-67 Coupe/El Camino w/ Rad Support Bushings.....	83.21 kit
DCC-1515	1964-67 Convertible w/o Rad Support Bushings.....	61.68 kit
DCC-1515RS	1965-67 Convertible w/ Rad Support Bushings.....	83.21 kit
DCC-1516	1968-72 Coupe/El Camino w/ Rad Support Bushings.....	69.52 kit
DCC-1517	1968-72 Convertible w/ Rad Support Bushings.....	92.76 kit

\* 1964 Chevilles did not originally require radiator support bushings.  
\* Convertibles do not require body spacers.



DCC-7377A

### 1973-77 Body Bushings

Complete 28 piece body bushing kit constructed out of rubber with steel inserts. Two of them are solid rubber plugs and the top cap bushings have steel washers molded into them just like factory. Featuring GM numbers (4) 330942, (12) 330955, (2) 377801, (2) 627662 and (4) 330951.

DCC-7377A	1973-77 (28 pc.) * .....	249.95 kit
BHP-7377	Bolt Kit .....	29.95 kit

\*Note: Hardware not included.

### Body Bushing Supplement Kit

Various big blocks required an additional 2 body bushings, so we put together this supplement kit complete with mounting hardware for these applications.

DCC-1518	1964-67 All .....	19.95 kit
DCC-1519	1968-72 All .....	19.95 kit

### Body Bushing Spacer

New correct style frame to body spacers for all cars except convertibles.

DCC-1500	1968-72 .....	8.95 ea.
----------	---------------	----------



### Polygraphite Body Mount Kit

These polyurethane body mounts offer increased performance and longevity over stock rubber bushings. Used for mounting body and radiator support to frame.

Add G to the part number for black  
Add R to part number for red.  
Example. 3-4111G is for 65-67 in black.

3-4128_	1964 Coupe .....	126.99 kit
3-4111_	1965-67 Coupe .....	126.99 kit
3-4112_	1965-67 Convertible.....	131.99 kit
3-4115_	1968-72 Coupe .....	94.99 kit
3-4114_	1968-72 Convertible.....	101.99 kit
3-4113_	1968-72 El Camino .....	94.99 kit
3-4170_	1968-72 Coupe w/ Hardware.....	196.99 kit
3-4141_	1978-88 G-Body.....	190.99 kit

No bolts or sleeves included unless noted. No Volume Discount.



DCC-0522

DCC-0521

### Radiator Support Bushing

Complete kit with all bushings and hardware for mounting radiator support to car.

DCC-0521	1965-67 All .....	26.99 kit
DCC-0522	1968-72 All .....	26.95 kit
DCC-0523	1973-77 All .....	26.95 kit



BHP-0516

### Body Bolt Kits

Correct black flanged head bolts and washers.

BHP-1643	1964-67 Coupe/El Camino .....	19.95 kit
BHP-1645	1964-67 Convertible.....	21.95 kit
BHP-0516	1968-72 Coupe/El Camino .....	22.95 kit
BHP-0517	1968-72 Convertible.....	23.95 kit

RFR-21159



### Body to Frame Repair

Complete kit of 14 large washers with the correct size hole for body bushings. Once welded in, these repair washers will provide your rusty old frame with the correct size hole.

RFR-21159	1964-72 All .....	36.95 kit
-----------	-------------------	-----------



UMI-4059-R



UMI-4059-B

### UMI Performance Rear Chassis Brace

This brace ties the two sides of the frame together between the shock towers over the rear axle.

UMI-4059-R	1964-67 Red .....	129.95 ea.
UMI-4059-B	1964-67 Black.....	129.95 ea.
UMI-4058-R	1968-72 Red .....	129.95 ea.
UMI-4058-B	1968-72 Black.....	129.95 ea.
UMI-3055-R	1978-88 Red .....	129.95 ea.
UMI-3055-B	1978-88 Black.....	129.95 ea.

Ships Oversize. No Volume Discount.

**CONTROL ARMS & RELATED**



UMI-401519-B



UMI-3016-B



UMI-3027-B



UMI-402118-R



UMI-30255-R



UMI-4014-R



**UMI Performance Rear Control Arms**

UMI's direct replacement lower control arms are designed to improve traction by replacing worn out factory bushings and weak stamped material. UMI offers a large variety of rear control arms designed for virtually any application. All control arms feature reinforced sway bar holes and are supplied with polyurethane bushings or Teflon® lined rod ends. Roto-Joints, which offer a good compromise between firm polyurethane bushings, soft rubber bushings and spherical rod ends are also available. The upper control arms are direct replacements to minimize wheel hop, improve cornering and help track consistency. They feature TIG and MIG welded construction and are assembled with polyurethane bushings, spherical rod ends or Roto-Joints.

Insert color choice in \_\_ R = Red B = Black

<b>1964-67</b>		
UMI-401518__	Tubular Rear .....	299.99 kit
UMI-401526__	Tubular Rear, Adjustable Uppers .....	399.95 kit
UMI-402126__	Boxed Rear, Adjustable Uppers .....	539.95 kit
UMI-401519__	Tubular Rear, On-Car Adjustable Uppers .....	399.95 kit
UMI-402118__	Tubular Upper, Box Lower .....	429.95 kit
UMI-402119__	Boxed Rear, On-Car Adjustable Uppers .....	539.95 kit
UMI-402418__	Non Adjustable Upper Poly F/R .....	369.99 kit
UMI-401419__	Adjustable Upper & Lower .....	459.95 kit
UMI-402719__	Double Adjustable Upper & Lower .....	539.95 kit
<b>1968-72</b>		
UMI-401516__	Tubular Rear .....	299.99 kit
UMI-401525__	Tubular Rear, Adjustable Uppers .....	399.95 kit
UMI-402125__	Boxed Rear, Adjustable Uppers .....	539.95 kit
UMI-402416__	Non Adjustable Upper Poly F/R .....	369.99 kit
UMI-401517__	Tubular Rear, On-Car Adjustable Uppers .....	429.95 kit
UMI-402116__	Tubular Upper, Box Lower .....	429.95 kit
UMI-402117__	Boxed Rear, On-Car Adjustable Uppers .....	539.95 kit
UMI-401417__	Adjustable Upper & Lower .....	459.95 kit
UMI-402717__	Double Adjustable Upper & Lower .....	539.95 kit
<b>1978-88</b>		
UMI-301516__	Tubular .....	299.99 kit
UMI-301517__	Tubular Adjustable Uppers .....	399.95 kit
UMI-301417__	Tubular Adjustable Uppers & Lower .....	459.95 kit
UMI-302717__	Tubular Double Adjustable Uppers & Lower .....	539.95 kit
UMI-302117__	Boxed Adjustable Uppers .....	539.95 kit

**Uppers and Loweres Sold Separately**

<b>Uppers</b>		
UMI-4018__	1964-67 Non Adjustable Poly Front Bushing Only .....	139.99 pr.
UMI-4044__	1964-67 Non Adjustable Roto Front Bushing Only .....	189.95 pr.
UMI-4019__	1964-67 Adjustable Rod End Front Bushing Only .....	239.95 pr.
UMI-4039__	1964-67 Adjustable Roto Front Bushing Only .....	259.95 pr.
UMI-4026__	1964-67 Adjustable Poly Front Bushing Only .....	239.95 pr.
UMI-402600__	1964-67 Adjustable Poly F/R Bushings .....	279.95 kit
UMI-4016__	1968-72 Non Adjustable Poly Front Bushing Only .....	139.99 pr.
UMI-4036__	1968-72 Non Adjustable Roto Front Bushing Only .....	189.95 pr.
UMI-4017__	1968-72 Adjustable Rod End Front Bushing Only .....	239.95 pr.
UMI-4037__	1968-72 Adjustable Roto Front Bushing Only .....	259.95 pr.
UMI-4025__	1968-72 Adjustable Poly Front Bushing Only .....	239.95 pr.
UMI-402500__	1968-72 Adjustable Poly F/R Bushings .....	279.95 kit
UMI-4019__	1964-67 Adjustable Rod End Front Bushing Only .....	239.95 pr.
UMI-3025__	1973-77 Adjustable Poly Front Bushing Only .....	239.95 pr.
UMI-3016__	1978-88 Non Adjustable Poly Front Bushing Only .....	139.99 pr.
UMI-3036__	1978-88 Non Adjustable Roto Front Bushing Only .....	189.95 pr.
UMI-3025__	1978-88 Adjustable Poly Front Bushing Only .....	239.95 pr.
UMI-3017__	1978-88 Adjustable Rod End Front Bushing Only .....	239.95 pr.
UMI-3037__	1978-88 Adjustable Roto Front Bushing Only .....	259.95 pr.
UMI-302500__	1978-88 Adjustable Poly F&R Bushing .....	279.95 pr.

**Lower Standards**

UMI-4015__	1964-72 Standard Tubular Poly F/R ..	159.95 pr.
UMI-4014__	1964-72 Standard Tubular Poly F Rod End R .....	219.95 pr.
UMI-4043__	1964-72 Standard Tubular Rod Ends F/R .....	379.95 pr.
UMI-4038__	1964-72 Standard Tubular Poly F Roto R .....	259.95 pr.
UMI-4040__	1964-72 Standard Tubular Roto F/R ..	299.95 pr.
UMI-4024__	1964-72 Standard Boxed Poly F/R ..	229.99 pr.
UMI-4021__	1964-72 Premium Boxed Poly F/R ..	299.95 pr.
UMI-4027__	1964-72 Double Adjustable Rod Ends F/R .....	299.95 kit
UMI-4041__	1964-72 Standard Boxed Poly F Roto R .....	279.95 pr.
UMI-4042__	1964-72 Standard Boxed Roto F/R ..	349.95 pr.
UMI-3015__	1978-88 Tubular Non Adjustable Poly F/R .....	159.95 pr.
UMI-3014__	1978-88 Tubular Adjustable Poly F Rod End R .....	219.95 pr.
UMI-3027__	1978-88 Tubular Double Adjustable Rod End F/R .....	299.95 pr.
UMI-3038__	1978-88 Tubular Non Adjustable Rod End F Roto .....	259.95 pr.
UMI-3040__	1978-88 Tubular Non Adjustable Roto F/R .....	299.95 pr.
UMI-3024__	1978-88 Boxed Non Adjustable Poly F/R .....	229.99 pr.
UMI-3041__	1978-88 Boxed Non Adjustable Poly F Roto R ..	279.95 pr.
UMI-3042__	1978-88 Boxed Non Adjustable Roto F/R .....	349.95 pr.

**Loweres Heavy Duty Cromoly**

These race style control arms are designed for aftermarket sway bars that do not attach to the control arms; control arms are supplied with no sway bar holes.

UMI-4023CM__	1964-72 Double Adjustable Rod Ends F/R .....	299.95 pr.
UMI-4023OFCM__	1964-72 Double Adjustable Rod Ends F/R Offset Ends* .....	299.95 pr.

\*These feature offset aluminum bushings and smaller diameter tubing that place the control arm inward for additional clearance when running large tires. No Volume Discount.





UMI-4022-B

**UMI Lower Control Lift Bars**

The UMI rear lift bars replace the factory rear control arms adding traction while not changing vehicle ride height. Lift bars work with axle torque to load the chassis of the car, forcing the rear wheels downward pushing the tires into the ground, resulting in harder launches and improved 60-foot times. Lift bars are designed to improve traction and reduce unwanted wheel hop. Lift bars feature greaseable polyurethane bushings which are designed to reduce bushing deflection while being street able. Lift bar kit features the correct provisions for adding a stock or aftermarket sway bar, the sway bar holes are placed in the correct pattern to maintain the sway bar level with the rear end while the lift bar is in the lowest hole. The rear mounting brackets feature three settings that allow the lift bar to be lowered 2, 2-3/4 or 3-1/4".

UMI-4022-R	1964-72 Bolt-in Red .....	399.95 kit
UMI-4022-B	1964-72 Bolt-in Black .....	399.95 kit
UMI-4020-R	1964-72 Weld-in Red .....	379.95 kit
UMI-4020-B	1964-72 Weld-in Black .....	379.95 kit
UMI-3022-R	1978-88 Bolt-in Red .....	399.95 pr.
UMI-3022-B	1978-88 Bolt-in Black .....	399.95 pr.
UMI-3020-R	1978-88 Weld-in Red .....	369.95 pr.
UMI-3020-B	1978-88 Weld-in Black .....	369.95 pr.

No Volume Discount.



UMI-4012-R

UMI-4010

**UMI Lower Control Arm Relocation Kits**

Optimize your Chevelle's instant center and improve forward traction by lowering the rear of the lower control arm 2, 2-3/4 or 3-1/4. These brackets are CAD designed to accommodate factory lower control arms as well as all popular aftermarket styles. Robust flanges inside the brackets add reinforcement and ensure factory bushings bolt right in. Brackets installed can provide an average 0.10 second (or better) 60-foot reduction and an overall improvement in launch consistency. Brackets are constructed of 3/16 mild steel and CNC laser cut for precision tolerances. Relocation brackets are designed to work on both lowered and non-lowered vehicles and feature multiple settings to optimize vehicle handling and traction.

UMI-4012-R	1964-72 Bolt-in Red .....	149.95 kit
UMI-4012-B	1964-72 Bolt-in Black .....	149.95 kit
UMI-4010	1964-72 Weld-in Bare .....	79.95 kit
UMI-3018-R	1978-88 Bolt-in Red .....	129.95 kit
UMI-3018-B	1978-88 Bolt-in Black .....	129.95 kit
UMI-3010	1978-88 Weld-in Bare .....	79.95 kit

No Volume Discount.



UMI-ABR824-R

**UMI Pro-Touring Rear Suspension Kit**

UMI's new pro-touring kit features all of our top of the line Pro-Tour style components in one convenient package. The GM A-Body lower control arms are loaded with Roto-Joints on each end and feature TIG welded sway bar sleeves along with the awesome articulation of the double Roto-UMI's. The upper arms have Roto-Joints on one end and are fully adjustable to set pinion angle and lateral location. Our new 2999 Roto-Joint axle housing bushing completes the package and ensures bind-free articulation. This 8 Roto-Joint package is the ultimate combination of street comfort and race winning capability. For Pro-Tour cars that see highway use, this kit is like having rod end suspension that just happens to be comfortable. 100% manufactured with pride in Philipsburg, PA - USA.

Insert color choice in \_\_\_\_  
R = Red B = Black

UMI-ABR724-__	1964-67 All .....	789.95 kit
UMI-ABR824-__	1968-72 All .....	789.95 kit
UMI-GBR024-__	1978-88 All .....	789.99 kit



UMI-3000-B

UMI-4004



UMI-2999



**UMI Control Arm Hardware**

Replacement hardware and bushings for your UMI control arms.

UMI-4002	1964-72 Rear Control Arm Bolts Factory Upgrade Set of 8 .....	25.95 kit
UMI-4004	1964-72 Front Control Arm Bolts w/ Aftermarket Arms Set of 8 .....	23.95 kit
UMI-4001	1964-72 Rear Control Arm Bolts Factory Upgrade Set of 4 .....	13.95 kit
UMI-4003	1964-72 Rear Control Arm Bolts Upper Set of 4 .....	10.95 kit
UMI-3002	1978-88 Rear Control Arm Bolts Factory Upgrade Set Of 8 .....	23.95 kit
UMI-3001	1978-88 Rear Control Arm Bolts Factory Upgrade Set Of 4 .....	11.95 kit
UMI-3013	1978-88 Front Control Arm Bolts Factory Upgrade Set Of 8 .....	23.95 kit
UMI-3011	1978-88 Front Control Arm Bolts Factory Upgrade Set Of 4 .....	12.95 kit
UMI-3012	1978-88 Front Upper Control Arm Bolts Factory Upgrade Set Of 4 .....	10.95 kit
UMI-3005-R	1964 Rear End Housing Bushing Red Poly w/o Shell .....	39.95 pr.
UMI-3005-B	1964 Rear End Housing Bushing Black Poly w/o Shell .....	39.95 pr.
UMI-3000-R	1965-72 Rear End Housing Bushing Red Poly w/ Shell .....	39.95 pr.
UMI-3000-B	1965-72 Rear End Housing Bushing Black Poly w/ Shell .....	39.95 pr.
UMI-2999	1965-88 Rear End Housing Bushing Roto Joint .....	159.95 pr.

No Volume Discount.



UMI-4029-R

**UMI Trailing Arm Reinforcements/Frame Braces**

Trailing arm mount braces are designed to reinforce the upper and lower front control arm mounts on your classic Chevelle. The more power your ride makes the better chance of bending or breaking the rear control arm mounts. These tubular reinforcements tie the upper and lower control arm mounts together for added strength and driving performance. Control arm braces are manufactured from DOM steel; TIG welded and feature adjustment for a perfect fit on all Chevelles. Kit includes new longer Grade 8 hardware, nuts and washers.

UMI-4029-R	1964-67 Red .....	149.99 kit
UMI-4029-B	1964-67 Black .....	149.99 kit
UMI-4028-R	1968-72 Red .....	149.99 kit
UMI-4028-B	1968-72 Black .....	149.99 kit

## REAR CONTROL ARMS



DZ-2500

### Rear Frame Crossmember Brackets

Dealer installed on most cars with manual transmissions to provide extra frame strength.

DZ-2500	1964-67 All	79.95 pr.
DZ-4500	1968-72 All	79.95 pr.



NMX-1600

### Rear Control Arm Bushings

New GM rubber rear control arm bushings.

NMX-1600	1964-77 All	15.95 ea.
NMX-1600K	1964-77 All (8pc)	114.95 kit

*Does not fit 1964 axle housing.*



BPB-1430

### Control Arm Bolt Rear

BPB-1430	All	7.99 ea.
----------	-----	----------

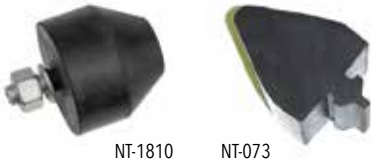

NT-1810

NT-073

### Rear End Bumpers

Correct OEM rubber stop bumpers.

NT-1810K	1964-72 All 3"	22.48 kit
NT-1810	1964-72 Upper	9.99 ea.
NT-073K	1964-72 Axle Tube	14.99 kit
NT-073	1964-72 Axle Tube	9.99 ea.
NT-987	1973-77 Axle Tube	22.99 ea.



NTK-6472

### Rear Axle Weld-On Bump Stop Brackets & Bumpers

If you plan on installing an aftermarket rear axle you'll want to pick up a set of these weld-on bump stop brackets & bumpers. Aftermarket axles do not have these bump stops.

NTK-6472	1964-72 Chevelle	59.99 kit
----------	------------------	-----------



DCA-640K



DCA-680K

### Rear Upper Control Arms

New OEM rear upper rear control arms complete with original GM rubber bushings. Buy the pair and save!

DCA-640K	1964-67 Upper Pair	179.91 pr.
DCA-680K	1968-72 Upper Pair	169.92 pr.
DCA-640	1964-67 Upper	99.95 ea.
DCA-680	1968-72 Upper	99.95 ea.
BPB-1430	Mounting Bolts	7.99 ea.

*No Volume Discount.*



NXJ-571

### Rear Lower Control Arms

These boxed lower arms were originally installed on most SS models and cars with F-41 suspension. All arms feature correct GM rubber bushings and are finished in semi gloss black.

NXJ-571	1964-72 Lower	175.95 pr.
BPB-1430	Mounting Bolts	7.99 ea.

*No Volume Discount.*



NXJ-6472

### Billet Rear Lower Control Arms With Polyurethane Bushings

These new billet lower control arms with polyurethane bushings will help dial in your Chevelle or El Camino's rear suspension for firmer, more controlled handling over stock components.

NXJ-6472	1964-72 All	359.95 pr.
NXJ-7888	1978-88 All	359.95 pr.

*No Volume Discount. Not eligible for free shipping.*

NJ-394

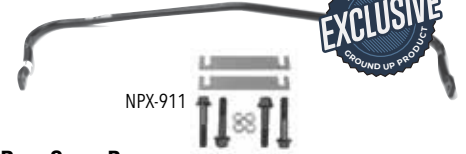

NPX-911



### Rear Sway Bar

Correct size original rear sway bar for F41. Add our mounting kit with OEM bolts, nuts and GM style shims.

NJ-394	1964-72 All Sway Bar	134.95 ea.
NJ-394K	1964-72 All w/ Hardware	127.60 kit
NPX-911	1964-72 All Hardware Kit	16.95 kit
DSB-696	1978-88 1" Kit	149.95 kit
BSB-78G	1978-88 Shim	12.99 ea.

*No Volume Discount. Not eligible for free shipping. Ships Oversized.*



DCK-1515



### Rear Sway Bar & Boxed Control Arms

Complete kit to convert your stock rear end to the F-41 Heavy Duty option. Kit includes rear sway bar, boxed lower control arms and correct attaching kit.

DCK-1515	1964-72 All	278.67 kit
----------	-------------	------------

*Ships Oversized. Not eligible for free shipping. No Volume Discount.*



### Rear Suspension Kit Complete

DRSK-1A

This F41 upgrade kit complete with rear sway bar with hardware, upper/lower boxed control arms and correct mounting bolts.

DRSK-2A	1964-67 All	502.92 kit
DRSK-1A	1968-72 All	502.92 kit

*Ships Oversized. Not eligible for free shipping. No Volume Discount.*



DSB-12959

### Sway Bar Washers

Correct washers used on the nut side so that the nuts do not dig into the arms.

DSB-12959	1964-72 (4 pc.)	9.99 kit
-----------	-----------------	----------

**REAR SUSPENSION**



DSE042201



**DSE Tubular Rear Sway Bar Kit**

Unlike the factory A Body sway bar, DSE's rear sway bar attaches to the rear end housing and to the chassis crossmember as opposed to the stock lower control arm mounted bar. By using the chassis to stabilize the rear axle as opposed to the stock lower control arm, deflection is minimized as the car is placed under a heavy cornering load.

DSE042201	1964-72 All .....	364.99 kit
DSE042202	1973-77 All .....	364.99 kit
DSE042206	1978-88 All 1" Bar .....	334.99 kit
DSE042206	1978-88 All 1-1/8" Bar.....	334.99 kit

*Ships Oversized. Not eligible for free shipping. No Volume Discount.*



DSE041603



**DSE Rear Speed Kit 1**

Detroit Speed and Engineering's rear Speed Kits are designed to make your Chevelle maintain optimum geometry and tire contact through the full range of rear suspension travel. Through the use of DSE's patented Swivel Links, the rear end housing becomes fully articulated, without the use of noisy spherical heim joints. Speed Kit 1 contains:

- Swivel Link Rear Control Arms • DSE Chassis Brace Kit

DSE041603	1964-67 All .....	1094.99 kit
DSE041604	1968-72 All .....	1059.99 kit

*\*Does not include chassis brace. Ships in Multiple Oversize Boxes. Not eligible for free shipping. No Volume Discount.*



DSE041609

**DSE Rear Speed Kit 2**

DSE's Speed Kit 2 includes everything in Speed Kit 1, but also gives you a DSE tubular rear sway bar which attaches to the chassis for a substantial improvement in cornering ability. Speed Kit 2 contains:

- Swivel Link Rear Control Arms
- Koni Classic Shock Absorbers
- DSE Chassis Brace Kit
- DSE Tubular Rear Sway Bar Kit
- DSE Rear Coil Springs

DSE041607	1964-66 All .....	1994.99 kit
DSE041609	1967 All .....	1994.99 kit
DSE041608	1968-72 All .....	1994.99 kit
DSE041610	1973-77 All .....	1839.99 kit
DSE043110	1978-88 All 2-3/7" Axle Tube .....	1829.99 kit
DSE043111	1978-88 All 3" Axle Tube.....	1829.99 kit

*Ships in Multiple Oversize Boxes. Not eligible for free shipping. No Volume Discount.*



DSE041611

**DSE Rear Speed Kit 3**

DSE's Speed Kit 3 is simply the best rear suspension available for a stock frame. This kit includes everything in Speed Kit 1 and Speed Kit 2.

Speed Kit 3 contains:

- Swivel Link Rear Control Arms
- DSE Specific Rear Coilover Shocks and Springs
- DSE Tubular Rear Sway Bar Kit
- DSE Chassis Brace Kit

DSE041611	1964-66 w/ Stock Axle .....	2659.99 kit
DSE041621	1964-66 w/ Moser Axle.....	2549.99 kit
DSE041613	1967 w/ Stock Axle.....	2659.99 kit
DSE041623	1967 w/ Moser Axle .....	2549.99 kit
DSE041612	1968-72 w/ Stock Axle .....	2549.99 kit
DSE041622	1968-72 w/ Moser Axle.....	2549.99 kit
DSE043120	1978-88 All 2-3/7" Axle Tube.....	2449.99 kit
DSE043121	1978-88 All 3" Axle Tube.....	2449.99 kit

*Ships in Multiple Oversize Boxes. Not eligible for free shipping. No Volume Discount.*



DSE042106

**DSE Swivel Link Kit**

DSE's unique A/G Body rear trailing links incorporate our patented Swivel-Link™ system. These Swivel-Links™ eliminate bind and allows the suspension to fully articulate without the use of noisy spherical rod ends. Swivel-Link™ Rear Links allow for easy pinion angle adjustment for improved traction and lower driveline vibrations.

DSE042106	1973-77 All .....	894.99 kit
-----------	-------------------	------------

*Not eligible for free shipping. No Volume Discount.*



DSE042301

**DSE Chassis Brace Kit**

DSE's chassis brace kit offers substantial improvements over the original rear chassis braces. By triangulating the rear crossmember, frame rail and upper control arm mount, rear chassis deflection is reduced.

DSE042301	1964-72 All .....	174.99 pr.
-----------	-------------------	------------

*Designed as a bolt-in for cars originally equipped with chassis braces, but can be installed on cars without original chassis braces with minimal effort.*

**SPRINGS**



**DSE Drop Coil Springs**

Give your Chevelle a modern pro touring stance while improving ride and handling with Detroit Speed and Engineering's new A-Body coil springs! These 2 inch dropped springs offer improvement in both ride and handling over soft factory coils.

<b>Front</b>	
DSE031115	1964-67 SB or LS ..... 212.99 pr.
DSE031118	1964-67 BB ..... 258.99 pr.
DSE031117	1968-72 SB or LS ..... 258.99 pr.
DSE031120	1968-72 BB ..... 258.99 pr.
DSE031123	1973-77 SB or LS ..... 258.99 pr.
DSE031124	1973-77 BB ..... 258.99 pr.
DSE031132	1978-88 SB ..... 194.99 pr.

<b>Rear</b>	
DSE041802	1964-66 All 1.5" Drop ..... 249.99 pr.
DSE041804	1967-72 All 1" Drop ..... 249.99 pr.
DSE041807	1973-77 All 1.5" Drop ..... 249.99 pr.
DSE041813	1978-88 All ..... 203.99 pr.

No Volume Discount.



**UMI Performance Springs**

UMI's springs are designed to add modern handling and a crisp ride while maintaining the factory muscle car appearance. They have a tough, black powder coat finish and UMI proudly manufactures these premium quality springs in the USA.

<b>Factory Height</b>	
UMI-4048	1964-66 Front/Rear Kit ..... 299.95 kit
UMI-4049	1967-72 Front/Rear Kit ..... 299.95 kit
UMI-4049F	1964-72 Front Set ..... 139.95 pr.
UMI-4048R	1964-66 Rear Set ..... 189.95 pr.
UMI-4049R	1967-72 Rear Set ..... 189.95 pr.

<b>Lowering Springs</b>	
UMI-4052	1964-66 Front/Rear Kit 1" Drop .... 299.95 kit
UMI-4053	1964-66 Front/Rear Kit 2" Drop .... 299.95 kit
UMI-4050	1967-72 Front/Rear Kit 1" Drop .... 299.95 kit
UMI-4051	1967-72 Front/Rear Kit 2" Drop .... 299.95 kit
UMI-3050	1978-88 Front/Rear 1" Drop ..... 299.95 kit
UMI-3051	1978-88 Front/Rear 2" Drop ..... 299.95 kit
UMI-4050F	1964-72 Front Set 1" Drop ..... 139.95 pr.
UMI-4051F	1964-72 Front Set 2" Drop ..... 139.95 pr.
UMI-3050F	1978-88 Front 1" Drop ..... 149.95 pr.
UMI-3051F	1978-88 Front 2" Drop ..... 149.95 pr.
UMI-4052R	1964-66 Rear Set 1" Drop ..... 189.95 pr.
UMI-4053R	1964-66 Rear Set 2" Drop ..... 189.95 pr.
UMI-4050R	1967-72 Rear Set 1" Drop ..... 189.95 pr.
UMI-4051R	1964-72 Rear Set 2" Drop ..... 189.95 pr.

No Volume Discount.



**Coil Springs**

Brand new OEM replacement coil springs sold in matched pairs. These are not cheap aftermarket springs. These springs will restore your car to the original ride height.

<b>Front</b>	
DCS-0060	1964-67 Chevelle SB w/o AC ..... 99.99 pr.
DCS-0160	1964-67 Chevelle SB w/ AC ..... 99.99 pr.
DCS-0160	1964-67 Chevelle BB w/o AC ..... 99.99 pr.
DCS-0160	1964-65 Chevelle BB w/ AC ..... 99.99 pr.
DCS-1160	1966-67 Chevelle BB w/ AC ..... 109.99 pr.
DCS-1168	1968-72 Chevelle SB w/o AC ..... 104.99 pr.
DCS-1169	1968-72 Chevelle SB w/ AC ..... 104.99 pr.
DCS-1169BB	1968-69 Chevelle BB w/o AC ..... 99.99 pr.
DCS-0360	1968-69 Chevelle BB w/ AC ..... 109.99 pr.
DCS-0360	1970-72 Chevelle BB w/o AC ..... 109.99 pr.
DCS-0360AC	1970-72 Chevelle BB w/ AC ..... 121.99 pr.
DCS-0160	1964-67 El Camino All SB/BB ..... 99.99 pr.
DCS-1168	1968-72 El Camino SB w/o AC ..... 104.99 pr.
DCS-1169	1968-72 El Camino SB w/ AC ..... 104.99 pr.
DCS-1169BB	1968-69 El Camino BB w/o AC ..... 99.99 pr.
DCS-5400	1968-72 El Camino BB w/ AC ..... 99.99 pr.
DCS-5600	1978-88 375lb Rate V6 Some V8 ..... 84.99 pr.
DCS-5606	1978-88 421lb Rate HD V8 ..... 99.99 pr.



**Rear**

DCS-6466	1964-66 Chevelle SB w/o AC ..... 84.99 pr.
DCS-6467	1964-66 Chevelle SB w/ AC ..... 99.99 pr.
DCS-6467	1964-66 Chevelle All BB ..... 99.99 pr.
DCS-0362	1967-72 Chevelle All SB ..... 82.99 pr.
DCS-67BB	1967 Chevelle All BB ..... 99.99 pr.
DCS-0362	1968-72 Chevelle All BB ..... 82.99 pr.
DCS-6467	1964-66 El Camino All ..... 99.99 pr.
DCS-E539	1967-69 El Camino All BB Heavy Duty ..... 149.99 pr.
DCS-E413	1970-72 El Camino All Heavy Duty ..... 99.99 pr.
DCS-6321	1978-88 Monte Carlo ..... 79.99 pr.



DSI-205

DSI-370

**Coil Spring Insulators**

Correct rubber insulators for rear coil springs with embedded fiber material as original.

DSI-205	1964-66 All Rear ..... 24.95 pr.
DSI-370	1967-77 All Rear ..... 9.95 pr.
DSI-170	1964-88 All Front ..... 17.99 pr.



DSC-64A

BSB-64A

**Rear Coil Spring Clamp And Bolts**

DSC-64A	1964-66 Rear Coil Spring Clamps ..... 29.99 pr.
BSB-64A	1964-66 Rear Coil Spring Clamp Bolts ..... 9.99 pr.



DSE030306

**DSE Front Coilover Kit**

Detroit Speed and Engineering's Coilover Conversion Kit allows the latest in coilover spring and shock technology to be bolted to any A-Body, bringing handling and ride into the 21st century! Perfect for your stocker or protouring Chevelle!

DSE030306	1964-72 SB or LS ..... 909.99 kit
DSE030307	1964-72 BB ..... 894.99 kit
DSE030310	1978-88 All ..... 909.99 kit

No Volume Discount.

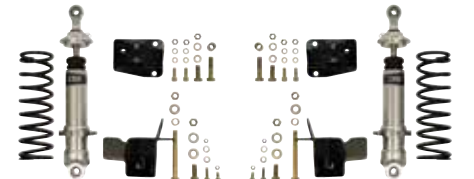

DSE042404

**DSE Rear Coilover Kit**

Detroit Speed and Engineering's A-Body coilover conversion kit allows the latest in coilover spring and shock technology to be bolted on to any A-Body, bringing your Chevelle's handling and ride into the 21st century! This package offers extensive ride height adjustability and DSE valving.

DSE042404	1964-66 All ..... 1224.99 kit
DSE042406	1967 All ..... 1224.99 kit
DSE042405	1968-72 All ..... 1224.99 kit
DSE042420	1978-88 All ..... 1149.99 kit

*Ships Oversized. Not eligible for free shipping.*

No Volume Discount.



AAS-300102

**Aldan American Coilover Kits**

Aldan Road Comp kits are designed to convert your suspension to coilovers. Aldan Phantom Series, single adjustable coilovers deliver superior handling and ride quality for a drastic improvement over stock suspension. Aldan high tensile, high travel coil-springs provide greater consistency over stock springs. Aldan's rear bolt-on shock absorber kit includes 2 TrueLine Series shocks, 2 brackets, 2 T-Bars and hardware. Uses OEM shock mounting locations. TrueLine adjustable shock absorbers are designed to work with factory and aftermarket springs to add a more consistent, smoother ride.

**Complete Front & Rear Kit with Rear Shock**

AAS-300168	1964-67 SB	910.99 kit
AAS-300169	1964-67 BB	910.99 kit
AAS-300170	1968-72 SB	910.99 kit
AAS-300171	1968-72 BB	910.99 kit
AAS-300110	1973-77 SB	910.99 kit
AAS-300111	1973-77 BB	910.99 kit

**Complete Front & Rear Kit with Rear Coilover**

AAS-300102	1964-67 SB	1246.99 kit
AAS-300103	1964-67 BB	1246.99 kit
AAS-300104	1968-72 SB	1246.99 kit
AAS-300105	1968-72 BB	1246.99 kit
AAS-300106	1978-88 SB	1257.99 kit
AAS-300107	1978-88 BB	1257.99 kit

**Front Coilover Kits**

AAS-ABFMS	1964-67 450lb Springs	518.99 kit
AAS-ABFHS	1964-67 550lb Springs	518.99 kit
AAS-AB2FMS	1968-72 450lb Springs	518.99 kit
AAS-AB2FHS	1968-72 550lb Springs	518.99 kit
AAS-AGFMS	1973-88 450lb Springs	518.99 kit
AAS-AGFHS	1973-88 550lb Springs	518.99 kit

**Rear Coilover Conversion Kits**

AAS-ABRLS	1964-72 120lb Springs Single Adjustable	728.99 kit
AAS-ABRMS	1964-72 140lb Springs Single Adjustable	728.99 kit
AAS-ABRHS	1964-72 160lb Springs Single Adjustable	728.99 kit
AAS-ABRNS	1964-72 No Springs Single Adjustable	615.99 kit
AAS-ABRLD	1964-72 120lb Springs Double Adjustable	817.99 kit
AAS-ABRMD	1964-72 140lb Springs Double Adjustable	817.99 kit
AAS-ABRHD	1964-72 160lb Springs Double Adjustable	817.99 kit
AAS-ABRND	1964-72 No Springs Double Adjustable	637.99 kit
AAS-AGRLS	1978-88 120lb Springs Single Adjustable	738.99 kit
AAS-AGRMS	1978-88 140lb Springs Single Adjustable	738.99 kit
AAS-AGRHS	1978-88 160lb Springs Single Adjustable	738.99 kit
AAS-AGRNS	1978-88 No Springs Single Adjustable	615.99 kit
AAS-AGRLD	1978-88 120lb Springs Double Adjustable	817.99 kit
AAS-AGRMD	1978-88 140lb Springs Double Adjustable	817.99 kit
AAS-AGRHD	1978-88 160lb Springs Double Adjustable	817.99 kit
AAS-AGRND	1978-88 No Springs Double Adjustable	637.99 kit

**Rear Shock Kits**

AAS-100110	1968-88 All	392.99 kit
------------	-------------	------------

No Volume Discount.



AAS-GSK-6872S



**Ground Up Exclusive Aldan Front Suspension Kits**

Ground Up's exclusive front suspension kit has the parts you need to upgrade your car's handling. We bundle together Ground Up's Tubular Front Control Arms and a set of Aldan American Coilovers in a specially discounted package. With Ground Up's exclusive front suspension kit, you'll be carving the corners in no time!

AAS-GSK-6872S	1968-72 Small Block	960.91 kit
AAS-GSK-6872B	1968-72 Big Block	960.91 kit

AAS-ALD-27



**Aldan American Tools**

Thrust bearings aka Torrington bearings make it easier to adjust spring tension and ride height when installed at the base of a coil spring and coilover spring seat. Includes 2 thrust bearings and 4 steel washers. 2.5 in. inner diameter, 3.225 in. outer diameter.

AAS-ALD-27	Bearings & Spanner Wrench	67.99 kit
AAS-ALD-26	Bearings Only	39.99 kit
AAS-ALD-1	Spanner Only	28.99 ea.

No Volume Discount.

**SHOCKS & RELATED**



KONI6477A

**Koni Front And Rear Shock Kits**

Are you looking for more performance from your shocks, and a smooth ride with improved ride and handling qualities? This Koni shock kit is the answer! Koni Classic shocks provide modern shock absorber technology for early muscle cars. Our kit includes: (2) front shocks, (2) rear shocks.

KONI6477A 1964-77 All ..... 479.36 kit  
No Volume Discount.



UMI-SS203052

**UMI Performance Shock And Spring Kits**

The UMI Performance Chevelle spring and shock kit is designed to provide a huge improvement in handling and control. These kits feature our race quality springs which provide a high performance foundation for your ride. Every component in this kit, as with all UMI products, is Made In USA.

UMI-SS203048 1964-66 Stock Height..... 839.99 kit  
 UMI-SS203049 1967 Stock Height ..... 839.99 kit  
 UMI-SS103049 1968-72 Stock Height..... 839.99 kit  
 UMI-SS203052 1964-66 1" Drop ..... 839.99 kit  
 UMI-SS203053 1964-66 2" Drop ..... 839.99 kit  
 UMI-SS203050 1967 1" Drop ..... 839.99 kit  
 UMI-SS203051 1967 2" Drop ..... 839.99 kit  
 UMI-SS103050 1968-72 1" Drop ..... 839.99 kit  
 UMI-SS103051 1968-72 2" Drop ..... 839.99 kit  
 UMI-SS103050G 1978-88 1" Drop ..... 839.99 kit  
 UMI-SS103051G 1978-88 2" Drop ..... 839.99 kit

*Ships Oversize. No Volume Discount.*



**GM Shock Kit**

Complete kit featuring 4 gas charged shocks, correct front & rear hardware, shock gray paint, & 4 shock ID decals.

DPX-440 1964-77 All ..... 136.64 kit  
 NT-2005 1964-77 Front Only ..... 29.99 ea.  
 NT-2201 1964-77 Rear Only..... 29.99 ea.

*No Volume Discount.*



**KYB Excel-G Shock Kit**

Are you looking for more performance from your shocks and a smooth ride? This KYB shock kit is the answer! They feature velocity sensing valving, hard chrome piston rods, twin tube design, low pressure nitrogen gas to prevent foaming of the oil, iron pistons & guide tubes. These shocks are great for normal to moderate driving! Our kit includes: (2) front shocks, (2) rear shocks and hardware.

KYB-64A-KIT 1964-67 All Front & Rear..... 114.95 kit  
 KYB-68A-KIT 1968-77 All Front & Rear..... 114.95 kit  
 KYB-64F 1964-67 Front Only ..... 34.95 ea.  
 KYB-68F 1968-77 Front Only..... 34.95 ea.  
 KYB-64R 1964-67 Rear Only..... 29.95 ea.  
 KYB-68R 1968-77 Rear Only..... 29.95 ea.

*No Volume Discount.*



DSR-384

**Shock Mounting Hardware**

Correct GM rubber bushings, cup washer and nut for one shock.

DSR-384 1964-88 All Front..... 7.95 kit



DR-041

**Shock Mounting Stud**

Correct rear shock mounting stud.

DR-041 1964-77 Rear..... 8.95 ea.



BPX-9715-REAR



BPX-9715

**Shock Mounting Kit**

BPX-9715 1964-88 All Front..... 6.95 kit  
 BPX-9715-REAR 1968-88 Rear Upper Shock Mounting Hardware..... 8.95 kit



9-8101G



9-8101R

**Poly Upper Front Shock Bushings**

If you want to upgrade to a more durable upper shock bushing these are the way to go.

9-8101G 1964-88 All Black..... 4.99 kit  
 9-8101R 1964-88 All Red..... 4.99 kit

One pair does one shock. Two required per car.

**NEW PRODUCT: QA1 SUSPENSION**

**QA1**

QA1-52418



**QA1 Upper & Lower Tubular Control Arms**

QA1's Street & Race Control Arms. The street arms use a factory replacement ball joint and polyurethane pivot bushings. These work great on vehicles used primarily for cruising and long distance events. The race arms utilize a QA1 Low Friction Ball Joint and low friction, low deflection pivot bushings, providing the added performance needed for drag racing, pro-touring and hardcore street applications. Configured for QA1 Pro Coil Systems, these control arms feature powder coated tubular construction for increased strength and great looks. A bolt-in spring adapter is available separately to allow the control arms to be used with stock springs. All of the upper arms feature an offset cross shaft letting you quickly and easily adjust camber. All of these arms are designed to add 3-4 degrees of caster and 0.5 to 1 degree of negative camber when used together. Includes mounting hardware. Made in the USA.

**Street Arms**

QA1-52422	1964-72 All Upper .....	449.99 pr.
QA1-52437	1964-72 All Lower .....	629.99 pr.
QA1-52418	1973-77 All Upper .....	449.99 pr.
QA1-52420	1973-77 All Lower .....	629.99 pr.
QA1-52465	1978-88 All Upper .....	449.99 pr.
QA1-52464	1978-88 All Lower .....	629.99 pr.

**Race Arms**

QA1-52322	1964-72 All Upper .....	549.99 pr.
QA1-52337	1964-72 All Lower .....	649.99 pr.
QA1-52318	1973-77 All Upper .....	549.99 pr.
QA1-52320	1977-77 All Lower .....	649.99 pr.
QA1-52365	1978-88 All Upper .....	549.99 pr.
QA1-52364	1978-88 All Lower .....	649.99 pr.

No Volume Discount.

QA1-52420



**QA1**

QA1-5249



QA1-5284

**QA1 Frame Braces**

QA1 Tubular Braces work with GM A-Body and G-Body trailing arms to reinforce the rear trailing arm mounts for major improvements in traction with less wheel hop and more power to the ground. Designed to clear stock and aftermarket mufflers. Made in the USA

QA1-5283	1964-67 All Adjustable.....	179.99 pr.
QA1-5212	1964-67 All Non-Adjustable.....	134.99 pr.
QA1-5284	1968-72 All Adjustable.....	179.99 pr.
QA1-5211	1968-72 All Non-Adjustable.....	134.99 pr.
QA1-5285	1978-88 All Adjustable.....	179.99 pr.
QA1-5210	1978-88 All Non-Adjustable.....	134.99 pr.

No Volume Discount.



QA1-5204

**QA1 Rear Trailing Arms**

All QA1 upper tubular and lower boxed trailing arms use polyurethane bushings on both ends, while upper adjustable and lower tubular trailing arms use a spherical ball or rod end assembly on the chassis end to eliminate bushing bind, allowing the suspension to move smoother for better control. This keeps the tires planted firmly on the ground for improved traction and a more predictable, better handling car. For a long-lasting finish, tubular and boxed trailing arms are powder coated gloss black, while the adjustable arms are zinc plated and anodized. Made in the USA.

QA1-5249	1964-67 All Upper Adjustable .....	269.99 pr.
QA1-5269	1964-67 All Upper Non-Adjustable.....	179.99 pr.
QA1-5248	1968-72 All Upper Adjustable .....	269.99 pr.
QA1-5268	1968-72 All Upper Non-Adjustable.....	179.99 pr.
QA1-5247	1973-88 All Upper Adjustable .....	269.99 pr.
QA1-5267	1973-88 All Upper Non-Adjustable.....	179.99 pr.
QA1-5205	1964-72 All Lower .....	269.99 pr.
QA1-5208	1973-77 All Lower .....	269.99 pr.
QA1-5204	1978-88 All Lower .....	269.99 pr.

No Volume Discount.

**QA1 Rear Anti-hop Bars**

QA1 Rear Anti-Hop Bars relocate the upper trailing arms to change the instant center of the rear suspension. This will improve the chassis reaction and increases forward bite and traction. The QA1 Anti-Hop Bars are one of the most effective and easily installed traction improvements. Includes graphite/polyurethane bushings. Made in the USA.

QA1-5213	1965-72 All .....	219.99 pr.
QA1-5214	1978-88 All .....	219.99 pr.

No Volume Discount.



QA1-5213



QA1-5252

**QA1 Tie Rod Sleeves**

These QA1 Heavy Duty Tie Rod Sleeves are manufactured from solid steel hex stock then zinc plated for durable good looks and corrosion resistance. These are stronger than stock OE split sleeves and easier to adjust. Made in the USA.

QA1-5250	1964-72 1978-88 All .....	64.99 pr.
QA1-5252	1971-77 All .....	64.99 pr.

No Volume Discount.

**QA1**



QA1-TN507

QA1-TN801

**QA1 Stocker Star Shocks**

These stock mount adjustable front & rear shocks are available for your Chevelle. Available in double, single, Drag R Series and non-adjustable options, these shocks provide exactly the ride you want, high performance handling and great looks. These QA1 aluminum shocks are 100% dyno tested and serialized before leaving our factory. Made in the USA. Easy, bolt-in installation.

QA1-TN507	1964-67 Front Non-Adjustable .....	119.99 ea.
QA1-TS507	1964-67 Front Single Adjustable .....	159.99 ea.
QA1-TD507	1964-67 Front Double Adjustable .....	239.99 ea.
QA1-TR507	1964-67 Front Drag Series Adj .....	169.99 ea.
QA1-TN505	1968-88 Front Non-Adjustable .....	119.99 ea.
QA1-TS505	1968-88 Front Single Adjustable .....	159.99 ea.
QA1-TD505	1968-88 Front Double Adjustable .....	239.99 ea.
QA1-TR505	1968-88 Front Drag Series Adj .....	169.99 ea.
QA1-TN801	1968-88 Rear Non-Adjustable .....	119.99 ea.
QA1-TS801	1968-88 Rear Single Adjustable .....	159.99 ea.
QA1-TD801	1968-88 Rear Double Adjustable.....	239.99 ea.

No Volume Discount.

**NEW PRODUCT: QA1 SUSPENSION (CONTINUED)**

**QA1**  
QA1-GR401-10500C



**QA1 Front Coilover Shock Kits**

QA1-GS501-10400A      QA1-MG401-10650C

The QA1 Pro Coil System is a great option for anyone looking for fully adjustable ride height and valving control. Choose a spring rate and adjust ability that fits your driving style, adjust the valving to match and you are on your way. These shocks also utilize a fully threaded body that allows you to adjust your ride height for the perfect stance or to finely tune the weight balance for superior handling. Specially designed for QA1's Pro Coil Systems, the American-made lightweight high travel springs have fewer coils and a smaller wire diameter, resulting in increased travel due to the larger distance between the coils. They reduce unsprung weight and react faster, optimizing suspension performance. Adjustable Pro Coil System Features: Available in MOD Series, independent compression and rebound double adjustable, simultaneous compression and rebound adjustable, or Drag R Series adjustable. Lightweight Billet Aluminum Coilover Shocks High Travel Springs Easy, Bolt-In Installation Ride Height Adjustable. Made in the USA

**Small Block Included spring rate: 400 Lbs, ideal for front axle weight between 1801-1900 Lbs.**

QA1-GS501-10400A	1964-67 Single Adjustable .....	545.99 kit
QA1-GD501-10400A	1964-67 Double Adjustable .....	705.99 kit
QA1-GR501-10400A	1964-67 Drag Series Adjustable .....	605.99 kit
QA1-MG501-10400A	1964-67 Mod Series .....	1525.99 kit
QA1-GS401-10400B	1968-72 Single Adjustable .....	545.99 kit
QA1-GD401-10400B	1968-72 Double Adjustable .....	705.99 kit
QA1-GR401-10400B	1968-72 Drag Series Adjustable .....	605.99 kit
QA1-MG401-10400B	1968-72 Mod Series .....	1525.99 kit
QA1-GS401-10550C	1973-77 Single Adjustable .....	545.99 kit
QA1-GD401-10550C	1973-77 Double Adjustable .....	705.99 kit
QA1-GR401-10550C	1973-77 Drag Series Adjustable .....	605.99 kit
QA1-MG401-10550C	1973-77 Mod Series .....	1525.99 kit
QA1-GS401-10400C	1978-88 Single Adjustable .....	545.99 kit
QA1-GD401-10400C	1978-88 Double Adjustable .....	705.99 kit
QA1-GR401-10400C	1978-88 Drag Series Adjustable .....	605.99 kit
QA1-MG401-10400C	1978-88 Mod Series .....	1525.99 kit

**Big Block Included spring rate: 500 Lbs, ideal for front axle weight between 2001-2100 Lbs.**

QA1-GS501-10500A	1964-67 Single Adjustable .....	545.99 kit
QA1-GD501-10500A	1964-67 Double Adjustable .....	705.99 kit
QA1-GR501-10500A	1964-67 Drag Series Adjustable .....	605.99 kit
QA1-MG501-10500A	1964-67 Mod Series .....	1525.99 kit
QA1-GS401-10500B	1968-72 Single Adjustable .....	545.99 kit
QA1-GD401-10500B	1968-72 Double Adjustable .....	705.99 kit
QA1-GR401-10500B	1968-72 Drag Series Adjustable .....	605.99 kit
QA1-MG401-10500B	1968-72 Mod Series .....	1525.99 kit
QA1-GS401-10650C	1973-77 Single Adjustable .....	545.99 kit
QA1-GD401-10650C	1973-77 Double Adjustable .....	705.99 kit
QA1-GR401-10650C	1973-77 Drag Series Adjustable .....	605.99 kit
QA1-MG401-10650C	1973-77 Mod Series .....	1525.99 kit
QA1-GS401-10500C	1978-88 Single Adjustable .....	545.99 kit
QA1-GD401-10500C	1978-88 Double Adjustable .....	705.99 kit
QA1-GR401-10500C	1978-88 Drag Series Adjustable .....	605.99 kit
QA1-MG401-10500C	1978-88 Mod Series .....	1525.99 kit

No Volume Discount.

**QA1 Sway Bars**

Give your chassis the stability it needs to keep your tires planted on the road. These sway bars are an easy bolt-on upgrade to help reduce body roll and handle corners better. For maximum strength and durability, QA1 sway bars are manufactured from either lightweight hollow-core (4130) chromoly steel or heavy duty solid-core (1045) cold formed steel. The bars are formed using precision CNC equipment for a true bolt-on installation, then gloss black powder coated for durability and corrosion resistance. Sway bars include new mounting components to replace old and worn out sway bar bushings and end links. Made in the USA.

QA1-52870	1964-72 All Front 1-1/4" .....	249.99 ea.	QA1-52894	1973-77 All Rear 1" .....	209.99 ea.
QA1-52893	1973-77 All Front 1-3/8" .....	259.99 ea.	QA1-52878	1978-88 All Rear 1" .....	209.99 ea.
QA1-52877	1978-88 All Front 1-3/8" .....	259.99 ea.	QA1-52873	1964-72 All Front & Rear 1-1/4"/1" .....	459.99 kit
QA1-52871	1964-72 All Rear 1" .....	209.99 ea.	QA1-52895	1973-77 All Front & Rear 1-3/8"/1" .....	469.99 kit
			QA1-52879	1978-88 All Front & Rear 1-3/8"/1" .....	469.99 kit

No Volume Discount.

**QA1**



**QA1 Rear Coilover Shock Kits**

QA1 bolt-in rear coilover conversion kits. These kits include specially designed USA made mounting brackets, single, double or MOD Series adjustable aluminum shocks, springs and all necessary hardware. Single adjustable shocks provide 18 positions of simultaneous rebound and compression adjustment while QA1's double adjustable shocks provide 18 positions of compression adjustment and 18 positions of rebound adjustment, for a total of 324 possible valving combinations. MOD Series shocks also feature a double adjustable design but include adjustable low-speed bleed as well for fully independent control over compression and rebound characteristics. These shocks also utilize a fully threaded body allowing for ride height adjust ability. Multiple spring rate options are also available, and have been successfully tested in various applications, from casual street driving to hardcore race applications. With our highly popular adjustable struts and the addition of the rear coilover conversion kit, you can now get a complete suspension makeover for both ends of the vehicle. Bolt-In installation. Made in the USA.

**Included spring rate: 130 Lbs, ideal for soft ride feel.**

QA1-RCK52339	1964-72 Single Adjustable .....	659.99 kit
QA1-RCK52335	1964-72 Double Adjustable .....	819.99 kit

**Included spring rate: 150 Lbs, ideal for medium ride feel.**

QA1-RCK52340	1964-72 Single Adjustable .....	659.99 kit
QA1-RCK52336	1964-72 Double Adjustable .....	819.99 kit

**Included spring rate: 170 Lbs, ideal for medium ride feel.**

QA1-RCK52341	1964-72 Single Adjustable .....	659.99 kit
QA1-RCK52337	1964-72 Double Adjustable .....	819.99 kit
QA1-RCK52375	1973-77 Single Adjustable .....	659.99 kit
QA1-RCK52371	1973-77 Double Adjustable .....	819.99 kit
QA1-RCK52351	1978-88 Single Adjustable .....	659.99 kit
QA1-RCK52355	1978-88 Double Adjustable .....	819.99 kit

**Included spring rate: 200 Lbs, ideal for firm ride feel.**

QA1-RCK52376	1973-77 Single Adjustable .....	659.99 kit
QA1-RCK52372	1973-77 Double Adjustable .....	819.99 kit
QA1-RCK52352	1973-77 Single Adjustable .....	659.99 kit
QA1-RCK52356	1973-77 Double Adjustable .....	819.99 kit

**Included spring rate: 220 Lbs, ideal for firm ride feel.**

QA1-RCK52377	1973-77 Single Adjustable .....	659.99 kit
QA1-RCK52373	1973-77 Double Adjustable .....	819.99 kit
QA1-RCK52353	1973-77 Single Adjustable .....	659.99 kit
QA1-RCK52357	1973-77 Double Adjustable .....	819.99 kit

No Volume Discount.





## NEW PRODUCT: QA1 SUSPENSION (CONTINUED)

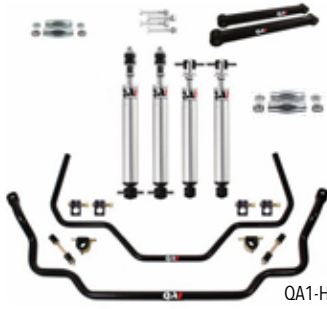

QA1-HK01-GMA1



QA1-HK01-GMG1



QA1-HK02-GMA3



QA1-HK03-GMG1



QA1-DK01-GMA1



QA1-DK12-GMG1

### QA1 Performance Handling Kits

Want better handling for your Chevelle? Turn to QA1's handling suspension kits for the best ride that fits your needs. Available in three different levels of performance, these handling kits offer easy, bolt-in installation and seamlessly works with whatever OE component each piece attaches to. You can build your car in stages using our parts list as a road map to get to the level of performance you want and have the peace of mind knowing you won't have compatibility issues.

**Level 1 Includes:** Front non-adjustable Stocker Star shocks, front & rear sway bar, tie rod adjuster sleeves, and rear lower boxed control arms.

**Level 2 Includes:** Front & rear single adjustable Pro coil shock system, front & rear sway bars, thrust bearing/spanner wrench kit, upper street control arms, lower street control arms, rear upper & lower tubular control arms, tubular rear control arm braces, tie rod adjuster sleeves.

**Level 3 Includes:** Front & rear double adjustable Pro coil shock system, front & rear sway bars, thrust bearing/spanner wrench kit, upper race control arms, lower race control arms, rear upper & lower boxed control arms, tubular rear control arm braces, tie rod adjuster sleeves.



#### Level 1 Kits

QA1-HK11-GMA1	1964-67 w/o Shocks .....	794.99 kit
QA1-HK01-GMA1	1964-67 w/ Shocks .....	1274.99 kit
QA1-HK11-GMA2	1968-72 w/o Shocks .....	729.99 kit
QA1-HK01-GMA2	1968-72 w/ Shocks .....	1209.99 kit
QA1-HK11-GMA3	1973-77 w/o Shocks .....	804.99 kit
QA1-HK01-GMA3	1973-77 w/ Shocks .....	1284.99 kit
QA1-HK11-GMG1	1978-88 w/o Shocks .....	939.99 kit
QA1-HK01-GMG1	1978-88 w/ Shocks .....	1419.99 kit

#### Level 2 Kits

QA1-HK12-GMA1	1964-67 w/o Shocks .....	2189.99 kit
QA1-HK02-GMA1	1964-67 w/ Shocks .....	3455.99 kit
QA1-HK12-GMA2	1968-72 w/o Shocks .....	2124.99 kit
QA1-HK02-GMA2	1968-72 w/ Shocks .....	3390.99 kit
QA1-HK12-GMA3	1973-77 w/o Shocks .....	2064.99 kit
QA1-HK02-GMA3	1973-77 w/ Shocks .....	3330.99 kit
QA1-HK12-GMG1	1978-88 w/o Shocks .....	2199.99 kit
QA1-HK02-GMG1	1978-88 w/ Shocks .....	3485.99 kit

#### Level 3 Kits

QA1-HK13-GMA1	1964-67 w/o Shocks .....	2471.99 kit
QA1-HK03-GMA1	1964-67 w/ Shocks .....	4057.99 kit
QA1-HK13-GMA2	1968-72 w/o Shocks .....	2406.99 kit
QA1-HK03-GMA2	1968-72 w/ Shocks .....	3992.99 kit
QA1-HK13-GMA3	1973-77 w/o Shocks .....	2301.99 kit
QA1-HK03-GMA3	1973-77 w/ Shocks .....	3887.99 kit
QA1-HK13-GMG1	1978-88 w/o Shocks .....	2481.99 kit
QA1-HK03-GMG1	1978-88 w/ Shocks .....	4087.99 kit

*Kits that do not include shocks may not have thrust bearings or spanner wrenches included. No Volume Discount.*

### QA1 Drag Race Suspension Kits

Looking for a better launch, straight line stability and consistent performance? Turn to QA1's drag racing suspension kits for a full-vehicle upgrade that fits your needs. Available in two different levels of performance, these drag racing kits offer easy, bolt-in installation and seamlessly works with whatever OE component each piece attaches to.

**Level 1 Includes:** Front R series Stocker Star shocks, upper street control arms, lower street control arms, stock spring seat adapter, tie rod adjuster sleeves.

**Level 2 Includes:** Front Double Adjustable Pro Coil shock system, thrust bearing/spanner wrench kit, Upper race control arms, Lower race control arms, tie rod adjuster sleeves, ball joint tool kit.

Available with and without shocks.

#### Level 1 Kits

QA1-DK01-GMA1	1964-67 w/ Shocks.....	1829.99 kit
QA1-DK11-GMA1	1964-67 w/o Shocks.....	1169.99 kit
QA1-DK01-GMA2	1968-72 w/ Shocks.....	1764.99 kit
QA1-DK11-GMA2	1968-72 w/o Shocks.....	1104.99 kit
QA1-DK01-GMA3	1973-77 w/ Shocks.....	1474.99 kit
QA1-DK11-GMA3	1973-77 w/o Shocks.....	814.99 kit
QA1-DK01-GMG1	1978-88 w/ Shocks.....	2999.99 kit
QA1-DK11-GMG1	1978-88 w/o Shocks.....	2339.99 kit

#### Level 2 Kits

QA1-DK02-GMA1	1964-67 w/ Shocks.....	4027.99 kit
QA1-DK12-GMA1	1964-67 w/o Shocks.....	2441.99 kit
QA1-DK02-GMA2	1968-72 w/ Shocks.....	3962.99 kit
QA1-DK12-GMA2	1968-72 w/o Shocks.....	2376.99 kit
QA1-DK02-GMA3	1973-77 w/ Shocks.....	3627.99 kit
QA1-DK12-GMA3	1973-77 w/o Shocks.....	2041.99 kit
QA1-DK02-GMG1	1978-88 w/ Shocks.....	4047.99 kit
QA1-DK12-GMG1	1978-88 w/o Shocks.....	2441.99 kit

*No Volume Discount.*

**POWER STEERING PUMPS & RELATED**

**Power Steering Conversion Kit**

Finally, a complete kit to convert from manual to power steering is available! This kit contains all of the needed parts to convert to the external reservoir power steering system used exclusively on all 1965-68 Chevelle SS 396's! All components available separately. See following pages!

Pump Adjuster Bracket (AAP-5810).....	22.95 ea.
Pressure Hose (1965-67 3880584, 1968 3928204).....	39.95 ea.
Pump (APS-6094).....	189.95 ea.
Cradle Bracket (ASB-872).....	45.95 ea.
Pump Pulley (ASP-509).....	36.95 ea.
Driver Pulley (ADP-61).....	44.95 ea.
Return Hose Kit (NPX-16).....	17.95 kit
Reservoir Hose (CPX-1580).....	9.95 ea.
Reservoir Canister (1965-67 CPZ-1512, 1968 CPZ-1935).....	59.95 ea.
Reservoir Cap (CPZ-1510).....	36.95 ea.
Reservoir Bracket (1965-66 CPZ-1511, 1967-68 CPZ-678).....	24.95 ea.
All Hardware (CPZ-1513).....	22.95 kit
<b>Total Price of Ordering All Parts Individually.....</b>	<b>553.40</b>

PSKIT-565	1965-66 Power Steering Kit.....	502.06 kit
PSKIT-567	1967 Power Steering Kit.....	502.06 kit
PSKIT-568	1968 Power Steering Kit.....	498.06 kit

*\*This kit does not include steering box, pitman arm or pulley nut.*



**Big Block Power Steering Conversion Kit 1969-72**

Are you tired of getting a workout every time you want to turn? Ground Up makes it easy to convert to power steering with this Chevelle power steering conversion kit! We have taken all of the guesswork out of selecting the parts to convert with this all in one solution! Includes: OEM Banjo Style Power Steering Pump, Pump Cap, Brackets, Hardware, Pulley, Pulley Nut, Pressure Hose, Return Hose.

PSKIT-69L	1969 BB w/o AC.....	286.14 kit
PSKIT-69LAC	1969 BB w/ AC.....	278.18 kit
PSKIT-70L	1970-72 BB w/o AC.....	293.72 kit
PSKIT-70LAC	1970-72 BB w/ AC.....	300.55 kit

*Note: For use with long water pump only. \*This kit is technically correct for 1970-1972 but can be used on any 1964-1972 Chevrolet with a big block and a long water pump.*



TUF-6193A



TUF-6193B

**Tuff Stuff Power Steering Pumps**

GM Saginaw style pumps feature all new components: reservoir, pump assembly, cap, dipstick and hardware when it applies. Rated at 1200 psi, rated to work with most gearbox systems.

TUF-6195A	1969 BB Chrome Banjo Style.....	235.99 ea.
TUF-6195B	1969 BB Black Banjo Style.....	186.99 ea.
TUF-6193A	1970 All Chrome Banjo Style.....	235.99 ea.
TUF-6193B	1970 All Black Banjo Style.....	186.99 ea.
TUF-6183A	1970-74 All Chrome.....	221.99 ea.
TUF-6183B	1970-74 All Black.....	174.99 ea.
TUF-5559	Universal Inline Filter.....	32.99 ea.

*No Volume Discount.*

**Power Steering Pumps Replacement**

Completely rebuilt second design power steering pumps. These pumps will differ in appearance from our originals, but will fit and function the same. No core charge!

**NO CORE CHARGE**

APS-6088R	1964-68 All SB.....	119.95 ea.
APS-6000R	1969 All BB.....	99.95 ea.
APS-6001R	1970-72 All.....	99.95 ea.

*No Volume Discount.*



**NO CORE CHARGE**



APS-6153

**Concourse Series "Banjo" Style Power Steering Pumps**

Brand New GM pumps with correct original style reservoirs. No core charge! Made in the USA!

APS-6088	1964-68 All SB.....	179.95 ea.
APS-6094	1965-68 All BB.....	189.95 ea.
APS-6153	1969 All SB.....	179.95 ea.
APS-6151	1969 All BB.....	179.95 ea.
APS-6165	1970-72 All*.....	179.95 ea.

*\*Use with 1970 hose & brackets. No Volume Discount.*



APS-6000R



ADR-077

**Power Steering Pump Cap**

Quality replacement power steering pump cap.

ADR-077	1964-77 All.....	8.95 ea.
---------	------------------	----------



APC-42

**OE Power Steering Pump Cap**

Reproduction metal cap.

APC-42	1964-77 All.....	19.95 ea.
--------	------------------	-----------



ASC-128

**Power Steering Hose Retaining Clip**

Correct clip for retaining hose to steering box

ASC-128	All V8.....	12.95 ea.
---------	-------------	-----------

## POWER STEERING PUMP PULLEYS



ADP-61

### 1965-68 396 Driver Pulley

Reproduction of the 1965-68 SS396 only power steering driver pulley. Fits inside crank pulley.

ADP-61 1965-68 BB Driver .....44.95 ea.



ASP-509

23-28

### Power Steering Pump Pulleys

Reproduction power steering pulleys.

ASP-3847 1965-68 1 Groove SHP .....155.95 ea.  
 ASP-509 1962-72 1 Groove.....36.95 ea.  
 ASP-107 1969-72 2 Groove w/ AC.....44.99 ea.  
 ASP-1395 1969-72 1 Groove SHP .....49.99 ea.  
 23-28 Pulley Nut .....3.95 ea.



GCS-S8848

### Billet Power Steering Pulleys

These show quality billet power steering pulleys will set your show car apart from the crowd. Made of high quality aircraft aluminum.

GCS-S8848 1 Groove, Satin.....36.99 ea.  
 GCS-S8848POL 1 Groove, Polished.....41.99 ea.  
 GCS-S8948 1 Groove, Chrome.....24.99 ea.  
 GCS-S8847 2 Groove, Satin.....41.99 ea.  
 GCS-S8847POL 2 Groove, Polished.....47.99 ea.  
 GCS-S8947 2 Groove, Chrome.....33.99 ea.



BSB-1970

### Power Steering Hardware Kits

Our kits feature all correct hardware to attach power steering brackets to engine. A MUST!

CPZ-1513 1965-68 SS 396.....22.95 kit  
 BSB-695B 1969-72 All SB.....11.99 kit  
 BSB-1969 1969 All BB.....17.99 kit  
 BSB-1970 1970-72 All BB.....12.95 kit

## POWER STEERING BRACKETS



ASB-7KIT

### 1970-72 Big Block Power Steering Bracket Kit

Complete kit with cradle, adjustment brackets and hardware.

ASB-7KIT 1970-72 All BB.....63.77 kit  
 Will work on most BB engines with long pump.  
 May need some modification.



ASB-9KIT

### 1969-72 Small Block Power Steering Bracket Kit

Complete kit with all three brackets.

ASB-9KIT 1969-72 SB.....88.07 kit

### Power Steering Brackets

Original style reproduction and original GM brackets.



ASB-383

ASB-383 1966-67 L-79 (2 pc.) .....39.95 kit



AQW-1418

AQW-1418 1969 All 396 (3 pc.)\* .....64.99 kit  
 \*Long water pump



ASB-3941

ASB-3941 1969-72 All SB Cradle.....25.95 ea.

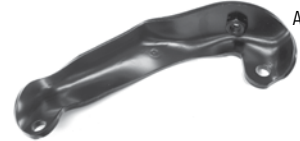

ASB-874

ASB-874 1969-72 SB Rear Support.....35.95 ea.



AAB-2610

AAB-2610 1969-72 SB Adjuster.....35.95 ea.



ASB-8072

ASB-8072 1964-68 all SB (Cradle) .....38.95 ea.a.



AAP-5910

AAP-5910 1964-68 SB Upper Adj. (to exhaust manifold).....29.95 ea.  
 \*will not work with headers



ASB-872

ASB-872 1965-68 All BB (Cradle).....45.95 ea.



AAP-5810

AAP-5810 1965-68 All BB (adj.).....22.95 ea.



ASB-422

ASB-422 1969-74 All BB Cradle ..... 32.95 ea.



ASB-931

ASB-931 1969-72 All BB (adjuster) ..... 24.95 ea.

**POWER STEERING HOSES**

**Power Steering OEM High Pressure Hose**  
New correctly bent OEM high pressure hoses with correct fittings.



CPX-6605

CPX-6605 1964-68 All SB ..... 24.95 ea.  
3880584 1964-68 All SS 396 BB ..... 39.95 ea.



3928204

3928204 1968 SS 396 ..... 39.95 ea.



CPX-6900

CPX-6900 1969 All SB ..... 24.95 ea.



CPX-6616

CPX-6616 1969 SS 396 ..... 26.95 ea.



CPX-6618

CPX-6618 1970-72 All ..... 26.95 ea.

**THIS IS AN EXCLUSIVE GROUND UP PRODUCT**



ARK-68B

**BUY'N SAVE WITH KITS**

**Power Steering Hose Kits**  
This kit comes with OEM high pressure hose, low pressure return tube, hose and correct clamps. Made in USA!

ARK-64A	1964-68 All SB	36.47 kit
ARK-65B	1965-67 SS 396	49.22 kit
ARK-68B	1968 SS 396	52.11 kit
ARK-69A	1969 All SB	38.61 kit
ARK-69B	1969 All BB	40.41 kit
ARK-70A	1970-72 All SB	40.41 kit
ARK-70B	1970-72 All BB	40.41 kit



NPX-16

**Power Steering Return Hose**

Complete with correct pre bent flared tube, OEM hose and correct clamps.

NPX-16	1964-72 All V8	17.95 kit
CPS-038	OEM Return Hose	2.95 per ft
CPN-512	OEM Clamps Screw Type	1.95 ea.



DSE091202

**DSE Power Steering Hose Kit**

Includes fittings to convert your steering gear to -6 AN fittings. High quality stainless steel hoses are Teflon lined to handle the high pressure demands of the steering system. The hoses come with pre-cripped stainless steel fittings to attach to the -6 AN fittings at the steering gear. Each kit includes 30 inches of hose length that can be routed and cut to length at the pump end.

DSE091202	1964-72	194.99 kit
-----------	---------	------------

No Volume Discount.

**POWER STEERING RESERVOIR**



CPZ-1512

**External Reservoir Canister**

New correct large mouth external canister for your 1965-68 SS 396 with factory power steering!

CPZ-1512	1965-67 Can	59.95 ea.
CPZ-1935	1968 Can	59.95 ea.



CPZ-1510

**External Reservoir Canister Cap**

Correct metal cap for reservoir canister.

CPZ-1510	1965-68 Cap	36.95 ea.
----------	-------------	-----------



CPZ-1511



CPZ-678

**External Reservoir Brackets**

Correct brackets for holding the external reservoir to the inner fender.

CPZ-1511	1965-66	24.95 ea.
CPZ-678	1967-68	24.95 ea.



CPX-1580

**External Reservoir Hose**

Correct hose that connects pump to canister.

CPX-1580	1965-68	9.95 ea.
----------	---------	----------



BSB-759

**Steering Box Bolt**

Complete with correct thick washer and bolt.

BSB-759	1964-72 All	6.99 ea.
---------	-------------	----------

**POWER STEERING GEAR BOX**



GBK-1A



**BUY'N SAVE**  
WITH KITS



ARC-12BK



**Power Steering Gear Box Kits**

Add on one of these awesome "close ratio" gear boxes to your conversion or on its own. These boxes are re-manufactured GM units and will add the ultimate handling to your ride. Our kit comes with steering box, steering coupler (rag joint) and correct attaching bolts. Choose from fast ratio or super fast ratio! Fits all 1964-76 Chevelle & El Camino! No core charge!

GBK-1A	3 - 3.5 Fast.....	298.24 kit
GBK-1SFA	2.5 Super Fast .....	417.32 kit

No Volume Discount. Ships UPS Oversized.  
Not eligible for free shipping.

**Manual Steering Gear Box Kits**

Add one of these rebuilt correct style standard ratio manual steering gearboxes, including the correct steering coupler/rag joint and steering box mounting bolts. These boxes are re-manufactured GM units. Our kits come complete with the box, rag joint and mounting bolts to the chassis. No core charge!

ARC-12AK	1964-69 Standard Ratio.....	324.78 kit
ARC-12BK	1970-72 Standard Ratio.....	324.78 kit
ARC-12SFK	1964-72 Super Fast Ratio .....	342.78 kit

No Volume Discount. Not eligible for free shipping.

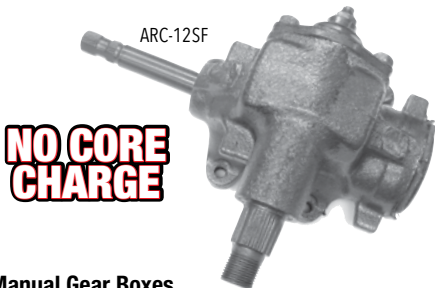

ARC-12SF

**NO CORE CHARGE**

**Manual Gear Boxes**

Complete re-manufactured original Saginaw assemblies.  
No core charge

ARC-12A	1964-69 24:1 Standard.....	289.95 ea.
ARC-12B	1970-72 24:1 Standard.....	289.95 ea.
ARC-12SF	1964-72 16:1 Quick.....	309.95 ea.

Use ATE-8869B coupler with ARC-12SF.  
No Volume Discount.



F-6859

BX-64K

**Pitman Arms**

F-6467M	1964-67 7/8" M/S.....	69.95 ea.
F-6467	1964-67 7/8" P/S.....	69.95 ea.
F-6859M	1964, 1968-72 13/16" M/S.....	79.95 ea.
F-6859	1964, 1968-72 13/16" P/S.....	69.95 ea.
BX-64K	Nut w/ Washer Fits All .....	6.95 ea.



**Intermediate Steering Shaft**

Restore proper steering stability and safety with this newly re-manufactured intermediate steering shaft. This shaft goes from the steering column down the steering box and wears out over time causing sloppy steering feel. This unit will fix that problem. This is a re-manufactured original GM unit that has been tested and painted.

IIS-68ASB	1968 SB.....	205.95 ea.
IIS-68ABB	1968 BB.....	308.95 ea.
IIS-69ASB	1969-72 SB.....	205.95 ea.
IIS-69ABB	1969-72 BB.....	308.95 ea.
DSB-83	1968-72 Upper Boot Only .....	32.95 ea.

Note: BB features correct removable lower flange.  
No Volume Discount.



ATE-8869A



ATE-8871

**Steering Coupler**

Complete joint for connecting column to box. 1964-68 with manual steering features fine spline and 1969-72 with manual steering features coarse spline.

ATE-8869A	1964-68 Manual.....	49.95 ea.
ATE-8869B	1969-72 Manual.....	49.95 ea.
ATE-8871	1964-72 Power .....	49.95 ea.

**Steering Coupler Bolt**

Correct OEM bolt for coupler.

ATJ-411	1964-72 All.....	5.99 ea.
---------	------------------	----------



ATJ-411



DS-740R-KIT

**1964-1967 Chevelle Steering Linkage Kits**

Sort out your steering and eliminate the guesswork with this convenient Ground Up kit. Each kit includes a matched power steering pitman arm, center drag link, idler arm, and pitman arm nut.

DS-740-KIT	1964-67 7/8" .....	193.44 kit
DS-740R-KIT	1964-67 13/16" .....	197.44 kit

No Volume Discount.



**THIS IS AN EXCLUSIVE GROUND UP PRODUCT**

**Flaming River Tilt Steering Column Kits**

Upgrade your old worn out steering column with this convenient Flaming River tilt column kit!

FR-A646K-P	1964-66 Paintable.....	935.97 kit
FR-A646K-BK	1964-66 Black.....	1088.07 kit
FR-A646K-PL	1964-66 Polished.....	1158.27 kit
FR-A678K-P	1967-68 Paintable.....	1098.87 kit
FR-A678K-BK	1967-68 Black.....	1254.57 kit
FR-A678K-PL	1967-68 Polished.....	1254.57 kit
FR-A6972K-P	1969-72 Paintable.....	1067.37 kit
FR-A6972K-BK	1969-72 Black.....	1151.97 kit
FR-A6972K-PL	1969-72 Polished.....	1328.37 kit

\*No Volume Discount.



**Flaming River Tilt Steering Columns**

Flaming River offers replacement tilt steering columns for your Chevelle. They require no welded on attachments or extra relays. Modeled after the popular muscle car Tilt Key Columns. Flaming River manufactures the column complete with a GM coded key assembly, wiring and ignition switch made from state-of-the-art, all new components. Made in the USA.

FR20005	1964-66 Paintable.....	544.99 ea.
FR20005BK	1964-66 Black.....	713.99 ea.
FR20005SS	1964-66 Polished.....	791.99 ea.
FR21019	1967-68 Paintable 1" 48 Spline.....	788.99 ea.
FR21019BK	1967-68 Black 1" 48 Spline.....	961.99 ea.
FR21019PL	1967-68 Polished 1" 48 Spline.....	961.99 ea.
FR21020	1967-68 Paintable 1" DD.....	610.99 ea.
FR21020BK	1967-68 Black 1" DD.....	753.99 ea.
FR21020PL	1967-68 Polished 1" DD.....	790.99 ea.
FR30009	1969-72 Paintable 1" 48 Spline.....	897.99 ea.
FR30009BK	1969-72 Black 1" 48 Spline.....	991.99 ea.
FR30009SS	1969-72 Polished 1" 48 Spline.....	1187.99 ea.

\*No Volume Discount.



**Flaming River Rack And Pinion Conversion Kits**

The Quick Ratio Rack and Pinion Cradle Systems are a great upgrade. The true fixture welded mounting cradle fits between the frame rails and bolts in place using the original chassis location. The system installs easily using simple hand tools and provides Full Turning Radius with a much more responsive steering system than the original.

**Manual Kits**

FR330KTM	1964-65 Paintable Column.....	2875.99 kit
FR366KTM	1966-67 Paintable Column.....	2875.99 kit
FR315KT	1968-72 Paintable Column No Key In Column.....	3920.99 kit
FR315KTK	1968-72 Paintable Column Key In Column.....	4247.99 kit
FR315KTKPL	1968-72 Polished Column Key In Column.....	4538.99 kit
FR315KTNC	1968-72 No Column.....	3763.99 kit

**Power Kits**

FR330KT	1964-65 Paintable Column.....	3118.99 kit
FR330KTPL	1964-65 Polished Column.....	3394.99 kit
FR330KTNPNC	1964-65 No Column No Pump.....	2678.99 kit
FR366KT	1966-67 Paintable Column.....	3118.99 kit
FR313KT	1968-72 Paintable Column No Key In Column.....	4084.99 kit
FR313KTK	1968-72 Paintable Column Key In Column.....	4416.99 kit
FR313KTKB	1968-72 Black PC Column Key In Column.....	4637.99 kit
FR313KTKPL	1968-72 Polished Column Key In Column.....	4709.99 kit
FR313KTNC	1968-72 No Column.....	3800.99 kit
FR1610	Hose And Fitting Kit.....	364.99 kit

No Volume Discount. Not eligible for free shipping



**Detroit Speed Rag Joint For 600 Steering Gear**

Detroit Speed replacement rag joint with 3/4 in. -30 spline coupling to be used with the DSE 600 series steering gear and your stock 1964-1972 Chevelle column. It comes complete with a clinch bolt.

DSE090205	1964-72.....	98.99 ea.
-----------	--------------	-----------

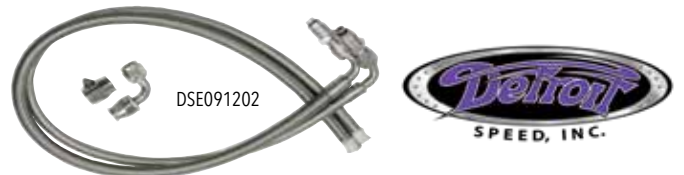

**Detroit Speed Power Steering Hose Kit For 600 Steering Gear**

This Detroit Speed and Engineering power steering hose kit includes fittings to convert your steering gear to -6 AN fittings. High quality stainless steel hoses are Teflon lined to handle the high pressure demands of the steering system. The hoses come with pre-cripped stainless steel fittings to attach to the -6 AN fittings at the steering gear. Each kit includes 30 inches of hose length that can be routed and cut to length at the pump end.

DSE091202	1964-72.....	194.99 kit
-----------	--------------	------------

Ships Oversize. No Volume Discount.