

ATE-3907



Open Element Air Cleaner

Excellent reproduction of the original GM open element air cleaner assembly. Complete base with elbow assembly, chrome plated lid and AC Delco filter. Will fit most V8's with 4 bbl. carburetor.

ATE-3907	Complete Kit	84.99 kit
ACQ-1224	Chrome Lid Only	36.95 ea.
ACQ-1220N	Chrome Lid Only w/ Service Instructions	59.95 ea.
AAC-8864	Base Only w/ Elbow Assembly.....	54.95 ea.

Everything You Need to Convert to Cowl Induction!

BUY 'N SAVE WITH KITS



Complete Cowl Induction Kit

This kit comes complete with every necessary item to install a functional cowl induction system on your 1967-69 Camaro with cowl induction hood. You get an air cleaner base, black lid, filter, steel flange, rubber seal, steel extension (where applicable), wiring harness, hood grommet, throttle arm, relay, electric solenoid, valve frame, flipper door, clips and hardware.

ACX-687	1967-69 Z/28	379.11 kit
ACX-688	1967-69 SB or 350	372.96 kit
ACX-689	1967-69 BB.....	360.74 kit
<i>No Volume Discount</i>		



GCS-10095

Black Steel Air Cleaner Assembly

This black air cleaner assembly is constructed of steel and is a great inexpensive custom touch to any street machine or sleeper. Includes lid, filter, base and wing nut.

GCS-10095	Holley.....	29.95 kit
GCS-10099	Edelbrock.....	29.95 kit



ACQ-1260

Cowl Induction Air Cleaner

OE style reproduction of original GM including base, lid and filter.

ACQ-1260	Complete Kit w/ Black Lid	129.99 kit
ACQ-1260Z	Complete Kit w/ Chrome Lid	149.99 kit
ACQ-60	Black Lid Only.....	29.99 ea.
ACQ-1224	Chrome Lid Only	36.95 ea.
<i>No Volume Discount. Will not work with HEI.</i>		

1967 Closed Air Cleaner System

New complete closed air cleaner assemblies for your 1967 Camaro complete with base, lid and filter!

ATW-3361	1967 SB Black Lid	145.95 kit
AM-3360	1967 396/325 or 350 HP*	149.95 kit
AM-3368	1967 Chrome Lid Only.....	74.99 ea.

*Can be used on SS350 models. *No Volume Discount.*



ATW-3361



ACC-569

1970-72 Dual Snorkel Air Cleaner

OE style reproduction complete with base and chrome lid. Originally equipped on non-cowl induction cars with L78 and L89 engine. Features correct snout with notch and PCV dimple.

ACC-569	1970	399.95 kit
---------	------------	------------

Note: Will not work with HEI.

ACX-79B without extension ring



ACX-79B

Cowl Induction Air Cleaner Kit

OE style reproduction of original GM including base, black lid, filter, flange, extension seal ring (where applicable) and rubber seal.

ACX-79	1967-69 Z/28 / 302	193.46 kit
ACX-79S	1967-69 350 / SB.....	188.28 kit
ACX-79B	1967-69 BB.....	162.77 kit

No Volume Discount



ACQ-1460

Dual Snorkel Air Cleaner Kit

OE style reproduction of the original 1970-74 Z/28 dual snorkel air cleaner assembly, complete with base, filter and lid.

ACQ-1460	1970-74 Complete Kit	184.99 ea.
ACQ-1461	1970-74 Chrome 17" Lid Only.....	59.95 ea.
ACQ-1462	1970-74 Black 17" Lid Only	29.95 ea.

No Volume Discount.



GCS-S6915C

GCS-S6813C

Ball Milled Air Cleaners

Highly polished ball milled flames aluminum 14" air cleaner. Includes washable 3" filter.

GCS-S6915	Flat Base w/ Flames.....	94.99 kit
GCS-S6905X	Drop Base w/ Flames.....	104.99 kit
GCS-S6815C	Drop Base.....	104.99 kit

Note: 5-1/8" carb opening.

Does not include stud, wing nut or gasket.



GCS-S6723

GCS-S6320

Finned Aluminum Air Cleaner

Highly polished finned aluminum 14" air cleaner. Includes washable 3" filter.

Round		
GCS-S6723	Flat Base.....	84.79 kit
GCS-S6725	Drop Base.....	84.79 kit

Oval

GCS-S6320	Flat Base.....	58.39 kit
-----------	----------------	-----------

Note: 5-1/8" carb opening. Includes mounting stud. Does not include wing nut or gasket.



GCS-S3196X

Stainless Steel Air Cleaner

Highly polished stainless steel 14" air cleaner. Includes washable 3" filter.

GCS-S8005X	Drop Base.....	50.39 kit
------------	----------------	-----------

Note: 5-1/8" carb opening. Includes mounting stud and chrome wing nut. Does not include gasket.

K&N Airfilter Kits

K&Ns custom air cleaner assemblies are designed with the racer in mind. They incorporate good looks as well as the superior air flow that you expect from K&N. These custom air cleaner assemblies are designed for use with any engine that uses a round element air cleaner housing. They incorporate K&N Air Filters and provide more air flow than other assemblies of this type. Each complete assembly comes with base, element and top plate. Provides more air flow to the engine, designed to increase horsepower, washable and reusable air filters.



Chrome Lid Drop Base

KN-60-1280	1967-81 14X3", 1-1/4" Drop Base.....	95.99 ea.
KN-60-1290	1967-81 14X4", 1-1/4" Drop Base...	130.99 ea.
KN-60-1300	1967-81 14X5", 1-1/4" Drop Base...	125.99 ea.
KN-60-1310	1967-81 14X6", 1-1/4" Drop Base...	123.99 ea.
KN-60-1430	1967-81 14X3", 7/8" Drop Base.....	116.99 ea.
KN-60-1440	1967-81 14X4", 7/8" Drop Base.....	118.99 ea.
KN-60-1450	1967-81 14X5", 7/8" Drop Base.....	127.99 ea.
KN-60-1460	1967-81 14X6", 7/8" Drop Base.....	129.99 ea.

Chrome Lid Raised Base

KN-60-1263	1967-81 14X2 5/16", 9/16" Raised Base.....	118.99 ea.
KN-60-1264	1967-81 14X3", 9/16" Raised Base.	104.99 ea.
KN-60-1260	1967-81 14X4", 9/16" Raised Base.	134.99 ea.
KN-60-1270	1967-81 14X4", 9/16" Raised Base.	145.99 ea.

X-Stream w/ Dropped Base

KN-66-3050	1967-81 14X3" 7/8" Drop Base.....	172.99 ea.
KN-66-3040	1967-81 14X3", 1-1/4" Drop Base...	131.99 ea.
KN-66-3060	1967-81 14X4", 1-1/4" Drop Base...	140.99 ea.
KN-66-3070	1967-81 14X5", 1-1/4" Drop Base...	187.99 ea.



N-1010



N-1012

Air Filter Exact Reproduction

OE style reproduction of the original style with "square mesh" design and original GM wording (silk screened) or AC Delco replacement style air filters.

N-1010	1970-74 Air Filter Horizontal Mesh.....	32.95 ea.
N-1012	1967-69 Air Filter Diagonal Mesh.....	32.95 ea.
ACW-212	All 14" AC Delco.....	10.95 ea.

X-Stream w/ Raised Base

KN-66-3000	1967-81 14X2 5/16", 9/16" Raised Base.....	174.99 ea.
KN-66-3010	1967-81 14X3", 9/16" Raised Base.	140.99 ea.
KN-66-3020	1967-81 14X4", 9/16" Raised Base.	187.99 ea.
KN-66-3030	1967-81 14X5", 9/16" Raised Base.	203.99 ea.

X-Stream Lid Only

KN-66-1401XB	1967-81 14" w/ Blue Trim Ring.....	89.99 ea.
KN-66-1401XP	1967-81 14" w/ Chrome Trim Ring...	80.99 ea.
KN-66-1401XR	1967-81 14" w/ Red Trim Ring.....	89.99 ea.
KN-66-1401	1967-81 14" w/ Black Trim Ring.....	72.99 ea.

Replacement Air Filter Only

KN-E3750	1967-81 14x4 Washable Filter.....	66.99 ea.
KN-E3760	1967-81 14x5 Washable Filter.....	75.99 ea.
KN-E3770	1967-81 14x6 Washable Filter.....	91.99 ea.

Recharger Care Kits

KN-99-5000	1967-81 w/ Aerosol Can.....	13.99 ea.
KN-99-5050	1967-81 w/ Squeeze Bottle.....	13.99 ea.

No Volume Discount.



FLOW-615101



Flowmaster Delta Force Cold Air Intakes

Unique Slip-Seal housing-filter-tube interface for a seamless installation. 4-layer dry air filter eliminates use of filter oils. Factory mounting locations for simple installation and designed to match the engine compartment for a stealthy appearance. Extensively dyno-tested for maximum performance.

FLOW-615101	2010-15 6.2L Black.....	309.99 ea.
FLOW-615104	2012-15 3.6L Black.....	313.99 ea.
FLOW-615102	2016-18 6.2L Black.....	284.99 ea.
FLOW-615103	2016-18 3.6L Black.....	313.99 ea.
FLOW-615143	2016-17 2.0L Black.....	341.99 ea.
FLOW-615025	2016-18 6.2 Air Filter Only.....	63.99 ea.

**Air filter insert for factory airbox only. No volume discount.*



Wing Nuts, Flame Arrester & Studs

APX-1400	Chrome Wing Nut.....	4.95 ea.
APX-7700	Black Wing Nut.....	4.95 ea.
ATE-5695	Flame Arrester.....	8.95 ea.

Carburetor Studs

APJ-2153	All w/Holley Open Element, 1.5".....	12.95 ea.
APJ-4153	All w/Cowl Induction.....	12.95 ea.
AP-315	All w/Q-Jet, 3 3/8".....	12.95 ea.
ATE-5256	Universal w/Point End, 4 1/4".....	8.95 ea.



HOJ-396-DC

Diecast Air Cleaner Decals

HOJ-(engine)-DC Diecast.....69.99 ea.
Ex. HOJ-396-DC for the decal above.



HOJ-375-DC

Diecast Turbo Jet Decals

HOJ-(Horsepower)-DC Diecast.....49.99 ea.
Ex. HOJ-375-DC for the decal above



Eddie Motorsports Billet Throttle Cable Brackets

These Eddie Motorsports billet GM throttle cable brackets mount to the base of Holley carburetors. The kit includes the cable mount bracket, return springs and bracket and installation hardware.

With 4150/4160 Series Carburetor

MS142-08B	1967-87 Blue.....	77.99 kit
MS142-08R	1967-87 Red.....	77.99 kit
MS142-08BA	1967-87 Black Anodized.....	77.99 kit
MS142-08CA	1967-87 Clear Anodized.....	77.99 kit

With 4500 Series Carburetor

MS142-09B	1967-87 Blue.....	102.99 kit
MS142-09R	1967-87 Red.....	102.99 kit
MS142-09BA	1967-87 Black Anodized.....	102.99 kit
MS142-09CA	1967-87 Clear Anodized.....	102.99 kit

No Volume Discount.



ACL-1267

Air Cleaner Rubber Seal

OE style reproduction rubber seal.

ACL-1267 1967-6921.99 ea.



AQW-293

Extension Seal Ring

OE style reproduction of the correct extension seal ring used for flange and seal.

AQW-293 1967-69 30229.99 ea.
 ACX-673 1967-69 SB except 30228.99 ea.



ACL-1295

Air Cleaner Flange

Correct steel flange for sealing the top of the air cleaner.

ACL-1295 1967-6927.99 ea.



AP-4B

Air Cleaner Gasket

Correct paper gasket for sealing air cleaner base to carburetor.

AP-2B All 2 bbl 3.95 ea.
 AP-4B All 4 bbl 4.95 ea.



ADR-476

Accelerator Arm & Rod

Correct throttle arm and rod for attaching it to the accelerator pedal for all 1967-69 Camaros.

A-9801 Thru-Rod26.99 ea.
 ADR-096B 1967 Big Block32.99 ea.
 ADR-476 Arm w/o Cowl Induc19.99 ea.
 ACI-3335 Arm w/ Cowl Induc18.99 ea.



Accelerator Cables

New GM service replacement cables with casings and bushings as original.

ATH-XR 1967-69 Cross Ram195.95 ea.
 ATH-6996 1970-81 All SB 4 bbl49.95 ea.
 ATH-3369 1970-81 All w/ Holley*41.95 ea.
 336969R 1970-81 Holley Repro18.95 ea.
 3972679R 1970-81 Q-Jet Repro18.95 ea.
 AZC-88 Cable Clip6.95 ea.
 AXJ-CE Cable Decal4.95 ea.
 ATH-99-BOLT 1967-690.25 ea.

*for use with ADT-0014 or 3972619 bracket.

No Volume Discount.



APJ-1302

1967-69 Accelerator Rod Kits

For those using rods, our kits come complete with pre-bent rod, swivel, grommet, sleeve and hardware.

NA-103 All 4 bbl Q-Jet29.99 kit
 APJ-1302 All Z/28 Holley29.99 kit
 APJ-1369 All BB Holley29.99 kit



3992376

Accelerator Brackets

Your choice of brackets with GM numbers or without GM numbers. Both fit as original.

3992376 w/ Q-Jet GM #'s32.95 ea.
 3972619 w/ Holley GM #'s32.95 ea.
 AXK-68 w/ Q-Jet No #'s22.95 ea.
 ADT-0014 w/ Holley No #'s19.95 ea.



ATH-3369KIT-H

Accelerator Cable & Bracket Kit - All BB/SB with SHP Holley

This new accelerator cable and bracket kit is the perfect solution for smooth operation when your originals are either worn or missing. This kit includes a reproduction accelerator cable, bracket and retaining clip.

ATH-3369KIT-H 1968-81 All41.27 kit

No Volume Discount.



Chrome Throttle Cable Brackets

Designed to work with your GM throttle cable on most carburetor applications. Available with or without kickdown provision.

GCS-S9619 w/o Kickdown7.99 kit
 GCS-S9620 w/ Kickdown8.49 kit

Note: Due to the universal nature of this part, fitting and/or modifications may be required.



DEMON-1900

Demon Carburetors

WICKED POWER! The ALL NEW Street Demon® redefines the street carburetor with clean looks and ease of use! The Street Demon offers enthusiasts a straight forward carburetor designed to deliver a stable idle, amazingly crisp throttle response and smooth performance. Its optimized calibration and dual mounting pattern make it Run-Ready™ Designed for use on most stock to mildly modified V8s! These carbs feature vacuum secondaries and an electric choke.

625 CFM Carburetors

DEMON-1900 Silver, w/ Aluminum Float Bowl ... 320.99 ea.
 DEMON-1901 Silver, w/ Composite Float Bowl ... 320.99 ea.
 DEMON-1901BK Black w/ Aluminum Float Bowl 386.99 ea.

750 CFM Carburetors

DEMON-1903 Silver w/ Aluminum Float Bowl ... 355.99 ea.
 DEMON-1904 Silver w/ Composite Float Bowl ... 355.99 ea.
 No volume discount.

Holley



HOL-0-1850SA

Holley Carburetors

Holley is one of the most trusted carburetors of all time! Its 600 CFM of airflow, vacuum secondaries, single fuel inlet and mechanical or electric choke makes it amazingly universal. The 4160 carbs are constructed from aluminum which compared to its zinc counterpart equates to a weight savings of 40%! Being aluminum also means it will hold its shine and can be hand polished for a custom look! Don't trust your performance to just anyone, Holley is the only modular carburetor company that has been in business for over 100 years and has powered every NASCAR champion since the 60's.

HOL-0-1850SA All 4160 600 CFM Manual Choke335.99 ea.
 HOL-0-80457SA All 4160 600 CFM Electric Choke341.99 ea.
 HOL-0-80670 All 4150 670 CFM Electric Choke470.99 ea.

No volume discount.



Quick Fuel Technology Carburetors

"Innovators in fuel systems" is more than just a by-line. Quick Fuel Technology, since its inception in 1998, has grown exponentially in its 11 years of business culminating into the benchmark by which performance carburetors are measured.



QF-HR-600



QF-SS-650



QF-Q-750

The Hot Rod Series is a versatile performer designed for the most discerning street enthusiast. Featuring lightweight die-cast aluminum components, the HR-Series offer all the tunability you would expect from more expensive racing carburetors, including changeable bleeds, idle feed, power valve channel restrictions, and four-corner idle. Offered in either vacuum or mechanical secondary models, all Hot Rod Series carburetors feature electric chokes and dual metering blocks for added performance. Now available in a 450 cfm model for applications with small displacement engines.

- All models feature a fully adjustable electric choke for easy starting
- Dual metering blocks w/ 4-corner idle for smooth and efficient idle quality
 - Screw-in air bleeds and idle feed restrictions for quick unsurpassed tuning capability
- Dual inlet fuel bowls with sight glass windows for safe, easy float adjustment
- Universal throttle lever with sealed throttle shafts for smooth operation • Tuneable secondary opening rate
 - Tumble polished for long lasting shine

4150 Carburetors Square Bore

QF-HR-600	600CFM Mechanical.....	491.99 ea.
QF-HR-650	650CFM Mechanical.....	491.99 ea.
QF-HR-750	750CFM Mechanical.....	543.99 ea.
QF-HR-850	850CFM Mechanical.....	577.99 ea.
QF-HR-680-VS	680CFM Vacuum.....	472.99 ea.
QF-HR-780-VS	780CFM Vacuum.....	489.99 ea.

No volume discount.



QF-SL-450-VS



QF-SQ-650

Slayer Series street carburetors are designed with many of the same innovations and features that are built into all QFT™ race-winning carburetors, including changeable air bleeds and power valve channel restrictions. It's designed with a secondary metering plate with changeable jets, and features all aluminum components for additional weight savings. All Slayer Series carburetors are equipped with universal throttle lever to accommodate a variety of models.

- Vacuum Secondaries • Electric Choke
- Single Metering Block • Secondary Metering Plate
- Cast Aluminum Throttle Body • Single Sight Glass Windows
- Changeable Air Bleeds • Adjustable Needles & Seats

4160 Carburetors Square Bore Dual Inlet

QF-SL-450-VS	450CFM Vacuum.....	340.99 ea.
QF-SL-600-VS	600CFM Vacuum.....	340.99 ea.
QF-SL-750-VS	750CFM Vacuum.....	369.99 ea.

4160 Carburetors Square Bore Single Inlet

QF-SL-1957E	600CFM Vacuum Silver.....	340.99 ea.
QF-BD-1957	600CFM Vacuum Black.....	413.99 ea.

No volume discount.

Super Street Series carburetors combine street-friendly drivability and track-capable performance in a single value-oriented package. Setting them apart from ordinary street carbs, they feature billet dual metering blocks and throttle-bodies that offer tighter tolerances and eliminate porosity. Not only are Super Street Series carbs available with both vacuum or mechanical secondaries, QFT™ also offers models designed and calibrated specifically for E85 fuel and blow-through forced induction applications. Running alternative fuel or boost no longer requires an expensive custom carburetor. All SS-Series carburetors are equipped with universal throttle levers to accommodate a variety of models. Bolting on the ultimate street/strip carburetor has never been easier.

- Red billet dual metering blocks & silver billet throttle bodies for improved durability
- Changeable idle, high-speed air bleeds & power valve restrictions
- Dual inlet fuel bowls with dual sight glass windows for easy float adjustment
 - 4-Corner idle for precise idle and smooth transition
 - Fully-adjustable electric choke with easy one wire hookup
 - Race-ready with notched secondary floats and jet extensions
 - Polished or Black Diamond™ finish available (some models)

4150 Carburetors Square Bore

QF-SS-650	650CFM Mechanical Silver.....	660.99 ea.
QF-SS-750	750CFM Mechanical Silver.....	660.99 ea.
QF-SS-850	850CFM Mechanical Silver.....	660.99 ea.
QF-BD-750	750CFM Mechanical Black.....	710.99 ea.
QF-SS-680-VS	680CFM Vacuum Silver.....	614.99 ea.
QF-SS-780-VS	780CFM Vacuum Silver.....	614.99 ea.

No volume discount.

Street-Q carburetor is intended to deliver legendary Q-Series performance to hardcore street enthusiasts at a reduced price. The major differences between the Street-Q and the race-bred Q-Series is the substitution of cast metering blocks and a cast throttle body in place of fully-machined billet components. All of the critical functionality is retained - 2-circuit metering, downleg boosters, changeable idle and high-speed air bleeds and 4-corner idle. A universal throttle lever to accommodate a variety of models.

- Lightweight die-cast aluminum components
- Changeable idle and high-speed air bleeds
- 2-circuit metering - 4-Corner idle system
 - Downleg boosters
 - 700-R4 mounting holes

4150 Carburetors Square Bore

QF-SQ-650	650CFM Mechanical Silver.....	526.99 ea.
QF-SQ-750	750CFM Mechanical Silver.....	566.99 ea.
QF-SQ-850	850CFM Mechanical Silver.....	582.99 ea.
QF-SQ-950	950CFM Mechanical Silver.....	595.99 ea.

No volume discount.

Q-Series Race carburetors are purpose-built for the dragstrip.

To combat the g's experienced during hard launches, Q-Series carbs are equipped with notched floats and secondary jet extensions. The high-flow aluminum main body isn't just lightweight, but it also features recessed air bleed cavities for improved air flow. Die-cast venturi are machined to exacting tolerances for outstanding throttle response. Billet metering blocks ensure a uniform fuel curve, while throttle-bodies enhance durability. For those days when track conditions vary from one pass to the next, QFT's QuickLink system makes adjusting the secondaries easy on models equipped with mechanical secondaries. The Q-Series is our most comprehensive line of carburetors, with applications available for use with gasoline, methanol, and E85 fuels, forced induction, drag race, circle track, and comes in both vacuum and mechanical secondary models.

- Lightweight aluminum main body
 - Mechanical secondary
- Aluminum fuel bowls with dual sight glass windows
- Billet metering blocks with 4-corner idle system
- Changeable idle feed and power valve channel restrictions
- PTFE coated and sealed shafts that have been slabbed for added air flow
- Red anodized billet metering blocks and throttle plate

4150 Carburetors Square Bore

QF-Q-750	750CFM Mechanical Silver/Red.....	764.99 ea.
QF-Q-750-B2	750CFM Mechanical Silver/Red*.....	819.99 ea.
QF-Q-850	850CFM Mechanical Silver/Red.....	819.99 ea.
QF-Q-950	950CFM Mechanical Silver/Red.....	873.99 ea.
QF-BDQ-750	750CFM Mechanical Black/Black.....	819.99 ea.

*Draw thru supercharger applications with 2 carbs. No volume discount.



QF-FX-4710

QFX-Series stands as the flagship model in QFT's lineup. Raised air horns improve entry angle into the venturi while ensuring undisturbed flow over the air bleeds. Annular boosters with CNC-machined billet aluminum inserts provide increased air flow, a stronger signal, and less turbulence. QFX carbs offer unparalleled fuel atomization with annular boosters specific for either gas, methanol, or E85 fuels. Five-emulsion billet metering blocks and four-corner idle circuits offer flexible tuneability that today's high-horsepower engines demand. Ready to run out of the box, the QFX-Series carburetor will help you get to the winner's circle.

- QFX aluminum main body w/raised venturi
- Billet aluminum metering blocks with screw in restrictions
- Aluminum fuel bowls with dual sight windows and fuel inlets
 - Viton .130" Needles and Seats
- Billet Aluminum annular booster inserts
- QuickLink™ adjustable secondary opening adjustment
- Hand assembled and engine tested

4500 Spread bore Dominator Style

QF-FX-4710	1150CFM Mechanical Black/Black.....	1108.99 ea.
------------	-------------------------------------	-------------

No volume discount.

CARBURETOR ACCESSORIES



AFP-4221

Carburetor Base Gaskets & Shields

Correct "stamped" gasket and stainless steel shield.

Gaskets

AFP-4221	1967-69 4 bbl. Q-Jet.....	6.95 ea.
AFP-4219	1970-72 4 bbl. Q-Jet.....	6.95 ea.
AFP-4222	1967-72 All Holley.....	6.95 ea.

Shield

ABB-7401	1967+ All Q-Jet.....	12.95 ea.
----------	----------------------	-----------



ABB-HOLY

Holley Carburetor Heat Shield

Fits all standard 4150 and 4160 4 bbl Holley carburetors. Features original part number and the common Chevy firing order.

ABB-HOLY	1967-92 With Holley	33.99 ea.
----------	---------------------------	-----------

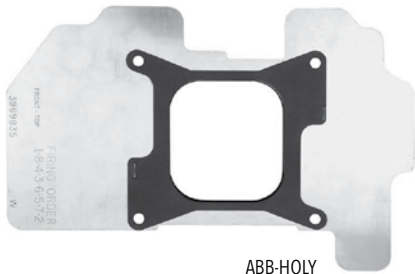

AS-761



AS-166



ACS-0069



ATE-0068



ACS-7454

Carb Return Springs

New correct color coded springs.

AS-761	1967-69 Q Jet Black	9.95 ea.
AS-166	1967-68 Holley Green	8.95 ea.
ACS-0069	1969 Holley Green	8.95 ea.
ATE-0068	1970-81 Q Jet Black	8.95 ea.
ACS-7454	1970-81 Holley Blue	9.95 ea.



GCS-S2083

Chrome Holley Carburetor Throttle Return Kit

Designed to make mounting the spring a snap! Works on most Holley carburetor applications. *Modifications may be required.*

GCS-S2083	Holley	11.99 kit
-----------	--------------	-----------



BMG-0095

Carb Attaching Kits

Correct OEM bolt kit for attaching carburetor to intake manifold.

BMG-0095	All w/ Holley	7.95 ea.
BTE-1475	All w/ Q-Jet.....	8.95 ea.



APX 1115

Engine Block Lifting Ring

These correct steel stamped lifting rings were installed at the engine plant for ease of installation.

APX-1015	Most SB	25.95 set
APX-1115	All BB	25.99 set
BPX-230	Lifting Ring Bolt.....	0.95 ea.



WND-8120WND

Weiland Street Warrior Intake Manifolds

The Weiland Street Warrior is designed for use on stock or stroker combinations that feature efficient cylinder heads. The latest advances in cam design necessitated the design of a new intake manifold, and the Weiland Street Warrior manifolds fill that void.

Square Bore Carburetors

WND-8120WND	Small Block w/ 55-86 Heads	165.99 ea.
WND-8121	Small Block w/ Vortec Heads	207.99 ea.

Spread Bore Carburetors

WND-8126	Small Block w/ 87-95 Heads	207.99 ea.
----------	----------------------------------	------------

No volume discount.

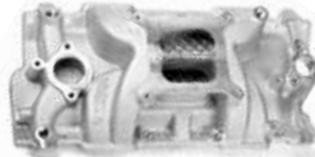

WND-8150

Weiland Speed Warrior Intake Manifolds

The Weiland Speed Warrior features long, separated runners for bottom-end and mid-range power, plus a special runner design and larger plenum to flow the air needed for high-rpm horsepower. All of this usable power makes this intake perfect for your street and strip hot rod!

WND-8150	Small Block W/55-86 Heads.....	177.99 ea.
WND-8170WND	Small Block W/87-95 Heads.....	188.99 ea.

No volume discount.



BPI-9140



BPI-2271

Intake Manifold Bolts OEM

Our OEM intake bolts feature correct size, coloring and head markings.

BPI-4400	All SB "M" Flanged 12pc	16.95 kit
BPI-9140	All BB "M" Cast Intake 16pc.....	21.95 kit
BPI-2271	All BB "A" Aluminum Intake 16pc.....	25.99 kit



BPS-3679



BPS-7432

Intake Studs

Correct intake manifold studs for various uses: alternator, solenoid and power brake tube. Includes correct nut.

BPS-3679	All 3/8" x 3/8" (Zinc).....	6.99 ea. (p.s. bracket, alternator mount, etc.)
BPS-7432	All 5/16" x 3/8" (Black).....	3.95 ea. (TCS, P.B. tube, etc.)



ACK-1679

Choke Kits

New OE style reproductions! Our kits come complete with thermal coil, cover, rod, retaining clip and screw.

ACK-1679	1967-69 SB Q-Jet	36.95 kit
ACK-6772	1967-71 Z/28.....	36.95 kit
ACK-8889	1967-69 BB Q-Jet.....	36.95 kit
ACK-1669	1967-69 BB Holley	36.95 kit
ACK-7072	1970-72 BB Q-Jet.....	36.95 kit
ACK-7071	1970 BB Holley.....	36.95 kit



APN-0138



APN-0238



APN-0038



APN-638



APN-738



APN-838

Intake Manifold Vacuum Fittings

OE style reproduction. These high quality fittings for rear of intake manifold have correct "slip on" and threaded ends. These fittings have a variety of uses: power brake hose, auto transmission, air conditioning, cruise control, etc. Guaranteed to look, fit and function exactly as original.

APN-0138	(1) Slip On Fitting.....	17.99 ea.
APN-0238	(2) Slip On Fittings	15.99 ea.
APN-0038	(1) Threaded Port.....	15.99 ea.
APN-638	(1) Threaded (1) Slip On	20.99 ea.
APN-738	(1) Threaded (2) Slip On	23.99 ea.
APN-838	(1) Threaded (3) Slip On	29.95 ea.



N-1252

Oil Filler Tube

Intake oil filler tube used with screw in PCV filter.

N-2258	1967-68 327 Black.....	36.95 ea.
N-1252	1967 SS350 / Z/28 Chrome.....	42.95 ea.
N-2290	1968 SS350 / Z/28 Chrome.....	51.95 ea.



AOC-1254



AOC-1689

Oil Filler Tube Cap

Correct twist on cap with "S" rivet.

AOC-1689	1967-68 327 Black.....	11.95 ea.
AOC-1254	1967-68 SS350 / Z/28 Chrome.....	17.95 ea.



AC-69SHP

1969 SHP PCV Valve

Correct purple PCV valve for Special High Performance engines.

CAC-69SHP	1969 w/ SHP	23.95 ea.
-----------	-------------------	-----------

CPX-9038

BUY'N SAVE
WITH KITS

PCV Hose & Filter Kit

Our kits come complete with correct GM hose, AC Delco filter and correct black pinch clamp. Pieces also available separately.

CPX-9038	All Complete	16.82 kit
CPH-9038	Hose Only	11.95 ea.
CTC-1132	Pinch Clamp Only	0.50 ea.
CAC-3800	PCV Filter Only	5.95 ea.



CPN-3819

AX-2963

PCV Retaining Hose Clip

OE style reproduction of original PCV hose retaining clip, with correct bends and black phosphate coating.

CPN-3819	1967-72 Z/28.....	16.99 ea.
CPN-3819	1967-69 BB w/ Holley.....	16.99 ea.
AX-2963	1967 BB Q-Jet.....	13.95 ea.

1114432



TCS Solenoid

Correct TCS solenoid which mounts to the carburetor stud. Includes correct brackets.

1114432	1970-71 350/400.....	104.95 ea.
1114434	1970 BB.....	104.95 ea.



APX-3002

Vacuum Advance Kits

Our kits come complete with correct pre-bent tapered tube(s), correct white stripe vacuum hose and correct clip.

APX-3002	1967-69 SB 2 bbl.....	20.99 kit
APX-3042	1967-69 SB 4 bbl.....	20.99 kit
APX-2628	1967-71 SB Holley.....	20.99 kit
APX-3940	1967-69 BB Q-Jet.....	21.99 kit
APX-3946	1967-69 BB Holley.....	20.99 kit



APX-4946K

1970 TCS Vacuum Advance Kits

This one year only design utilized two steel tubes and a double clip.

APX-3944K	1970 BB Q-Jet TCS	29.99 kit
APX-4946K	1970 BB Holley TCS	29.99 kit



APR-4060

AX-301

CPN-100

Vacuum Advance Clips

Correct clip for retaining tube to intake manifold.

APR-4060	All V8.....	8.95 ea.
AX-301	1970 w/ TCS	13.95 ea.
CPN-100	Hose.....	1.95 per ft

THERMOSTAT

Tuff Stuff Performance Thermostats

These thermostats flow up to 56 gallons per minute, as compared to ordinary thermostats that flow 37 gallons per minute, to maintain stated temperature. The 50 percent increased coolant flow reduces the delay in engine warm-up times, allowing trapped air in the cooling system to escape and stabilize the pressure of the cooling system. The stainless steel construction with an extra-large center port assures increased coolant flow and bridge design increases strength, stability & reliability and incorporates a bypass valve that allows a small amount of coolant to circulate before fully opening, assuring a fast warm-up. Ideal for high performance muscle cars, street rods and customs.



TUF-900160	160 Degree.....	17.99 ea.
TUF-900180	180 Degree.....	17.99 ea.
TUF-900195	195 Degree.....	17.99 ea.

No volume discount.



ACT-180

Thermostat

Original AC-Delco thermostat.

ACT-180	180-85 Degrees.....	6.95 ea.
ACT-190	190-95 Degrees.....	6.95 ea.



ABR-7660

Thermostat Housing

Correct thermostat housing for cast iron manifolds. This was the most common housing and was found on most V8's.

ABR-7660	Most V8.....	14.95 ea.
----------	--------------	-----------



ACI-7660

Thermostat Housing

Correct thermostat housing for high performance engines with aluminum intake manifolds. GM #3877660.

ACI-7660	Aluminum.....	45.99 ea.
----------	---------------	-----------



ATE-7396

Z/28 Thermostat Housing

This is the correct gooseneck style thermostat housing for your Z/28 engine.

ATE-7396	1967-68 Z/28.....	59.95 ea.
----------	-------------------	-----------



GCS-S9229

Chrome Thermostat Housing

Chrome steel thermostat housing with o-ring and bolts. Water neck points toward the driver side of the radiator.

GCS-S9229	Most V8.....	11.04 kit
-----------	--------------	-----------



ATR-1039

ATR-2039

Thermostat Housing Bolts

Correct TR head marked bolts for attaching to intake.

ATR-1039	1969+ SB.....	7.95 ea.
ATR-2039	1967-74 BB.....	7.95 ea.

IGNITION



A2525 1971244



Distributor Cap

Choose from AC Delco replacement distributor cap or exact reproduction distributor cap with GM numbers. Red cap features heavy duty brass terminals for high performance engines.

A2525	Red Cap.....	79.95 ea.
1971244	Black Cap.....	69.95 ea.
AAD-308	Replacement.....	22.95 ea.



ADS-2100-SC-CLEAR

ADS-2100-SC-RED

HEI Distributor

HEI Electronic Distributor with 50K Coil - Red Cap

ADS-2100	All.....	72.99 ea.
ADS-2100-SC-RED	Red Super Cap.....	102.99 ea.
ADS-2100-SC-CLEAR	Clear Super Cap.....	108.99 ea.



ACCEL-59107

Accel Replacement HEI Distributor

Using all new components, these distributors feature: High performance ACCEL Electronics. All new components-housing castings, ce. Direct plug in replacement with factory type connector. Fits standard deck height small and big block engines. Coil Not Included!

ACCEL-59107	All w/ HEI.....	107.99 ea.
-------------	-----------------	------------

No volume discount



MSD-8360

MSD Pro Billet Distributor

The Pro-Billet Ready-to-Run distributor is the perfect upgrade for outdated points distributors or bulky HEIs. Simply install the distributor in the engine, connect three wires, the coil and fire it up!

MSD-8360	Chevy V8*.....	361.99 ea.
MSD-85551	Chevy V8**.....	281.99 ea.

*Does not have nor can accept a vacuum advance canister.
**Must be used with a MSD 6,7, or 8 ignition box.
Note: Standard deck height blocks only. Will not fit gen 5 and 6 big blocks. No volume discount.



MSD-8362

MSD HEI Distributor

For value conscious enthusiasts, the Street Fire HEI is a great choice! We know the importance of a centrifugal advance in a distributor so our engineers made sure that the Street Fire received an advance assembly with coated weights and welded weight pins (not just pressed in like other models). Another area that you cannot afford to scrimp on is with a distributor gear. The Street Fire is fit with the same gear that is used on our Pro-Billet models. The metallurgy of this gear has been refined for years to perform through the harshest conditions

MSD-8362	All, Red Cap 4 Pin*.....	167.99 ea.
MSD-8365	All Billet, Red Cap 4 Pin*.....	448.99 ea.

Note: Standard deck height blocks only. Will not fit gen 5 and 6 big blocks.*Refers to the amount of terminals on the ignition module. No volume discount.



MAL-374820

Mallory Unilite Distributor

A legend returns - the tried and true Mallory Unilite Distributor line is back! The easy three wire hookup of the Unilite makes running a stock coil, a Mallory performance coil and even a Mallory HyFire CD ignition a snap. Supplied with a quality cap and rotor, the Mallory Unilite also provides a fully adjustable mechanical advance to dial in the perfect timing curve for a multitude of engine combinations. The Unilite features a compact housing that lends itself well to applications where space is a premium due to tight firewall clearance or blower applications.

MAL-3748201	All SBC, BBC*.....	318.99 ea.
-------------	--------------------	------------

*Standard deck height blocks only. Will not fit gen 5 and 6 big blocks. No volume discount.



ACE-1400

Distributor Hold Down

Correct retaining hardware for distributors.

ACE-1400	All V8.....	4.95 kit
----------	-------------	----------



GCS-S4116

GCS-S5116

Custom Distributor Hold Down Kit

Designed to secure your distributor settings and look good doing it. Choose from chrome or billet.

GCS-S4116	Chrome.....	3.99 ea.
GCS-S5116	Billet.....	15.29 ea.

N-2441



Tune Up Kit

AC Delco tune up kit with new points, condenser and rotor.

N-2441	1967-74 w/o HEI.....	45.95 ea.
--------	----------------------	-----------



1115263 (Top View)

1115270

Coil

Choose from our new exact reproduction Delco coils with GM numbers or GM replacement coil.

1115287	1968-72 BB.....	139.95 ea.
1115270	1968-72 SB.....	139.95 ea.
1115263	1967-72 Trans. Ign.*.....	149.95 ea.
1115293	1970-72 Most V8.....	139.95 ea.
GAC-505	1967+ Most Replace.....	39.95 ea.

*427/454 transistor ignition. No Volume Discount.



ALI-3119

BAN-516

Coil Bracket

OE style reproduction of original comes with retaining screw.

ALI-3119	All V8	19.99 ea.
BAN-516	Correct SEMS Bolts	1.95 pr.



GCS-S9366

Chrome Ignition Coil Bracket

This brightly chrome plated ignition coil bracket will look great in your engine compartment. Fits most round cylinder style ignition coils.

GCS-S9366	Coil Bracket	7.19 ea.
-----------	--------------------	----------



MSD-6201

MSD Ignition

An MSD Ignition will improve the overall performance of your engine thanks to its high output capacitive discharge sparks. Below 3,000 rpm the ignition delivers multiple sparks that will clean up the idle, improve starting and throttle response. If you're looking to improve the performance of your modified mill, we have the answer. Whether you've done a cam swap, or bolted on a carb, intake and headers the 6A is a surefire way to harness all the ponies under your hood. Step up to the 6AL to have an engine saving rev limiter.

MSD-6201	Red All 6A	232.99 ea.
MSD-6425	Red All 6AL	269.99 ea.
MSD-64253	Black All 6AL	269.99 ea.
MSD-6421	Red All 6AL-2	321.99 ea.

No volume discount.



MSD-35593



MSD-31359



MSD Ignition Spark Plug Wires

Engineered from the inside out, the 8.5 offers everything you have ever wanted in a wire; incredibly low resistance without electronic interference! In a single 12 inch length of Super Conductor Wire there is only 40 - 50 ohms of resistance!

Without Headers

MSD-31359	Red, SBC 350 HEI	94.99 kit
-----------	------------------------	-----------

With Headers

MSD-35593	Black, SBC 350 HEI* Cap	97.99 kit
MSD-35599	Red, SBC 350 HEI* Cap	97.99 kit
MSD-35603	Black, BBC 350 HEI* Tower Cap	101.99 kit
MSD-35609	Red, BBC 350 HEI* Tower Cap	101.99 kit
MSD-35653	Black, SBC 350 HEI* Tower Cap	99.99 kit
MSD-35659	Black, SBC 350 HEI* Cap	99.99 kit

*Works on any HEI or MSD style cap with male terminals.

No volume discount.



ALL-70BB3Q

"Dated" Spark Plug Wire Set

New OE style reproduction wire set correctly dated for your specific car, pre-cut and ready to install! Each set features correct colored wires and correct angled boots. Please give your sales rep your desired date. For points style, non-HEI cars only.

Here's how to order:

ALL-(year)(block)(quarter)

79.99 set
Note: For example, a 1970 Camaro SS396 built on or before Jan. 15, 1970, you would order ALL-70BB3Q wires will have 3-Q-69 stamped on them. If built after Jan. 15, 1970, you would order ALL-70BB1Q.



AHC-1508

Spark Plug Wire Sets

Pre-cut factory replacements.

AHC-1508	1967-73 SB non-HEI	39.95 set
AHC-2508	1967-72 BB non-HEI	39.95 set
AHC-3508	1974-81 with HEI	52.95 set



AC43

AC Delco Spark Plugs

This is a brand new set of 8 spark plugs for your Camaro. These high quality reproduction AC Delco spark plugs feature the correct green AC and markings as original.

AC43	1964-70 #43	59.95 set
AC44	1964-70 #44	59.95 set
AC45	1964-70 #45	59.95 set

Note: The number on the plug refers to it's operating temperature. The lower number is a cooler running plug which is typically found on the SHP high performance engines. A hotter, higher numbered plug would be used in engines where plug fouling may be or is a problem.



APX-6584

Spark Plug Heat Shield Kit BB

Correct stamped shields for various Chevrolet cars with BB engines (8 pcs.)

APX-6584	1967-72 BB 8pc	38.95 kit
----------	----------------------	-----------



AT-3030

OEM Style Spark Plug Heat Shield Kit BB

This is a set of correctly stamped spark plug heat shields which are silver cadmium plated.

AT-3030	1967-72 BB	49.95 kit
---------	------------------	-----------



APX-650

Spark Plug Heat Shield Kit SB

Correct die stamped shields and arms for most small blocks without Rams Horn style manifolds. Complete with mounting hardware.

APX-650	1967-74 SB.....	36.95 kit
BXX-650	Bolts (4).....	1.00 kit



APX-5022

Valve Cover Spark Plug Wire Loom Kits

Correct spark plug wire separators for valve covers

APX-5022	SB 6pc.....	19.95 kit
APX-5023	BB 4pc.....	11.95 kit



APX-1300 APX-8100 APX-1200

Wire Separators

Correct spark plug wire separators

APX-1300	1969-72 SB/BB Left Rear.....	16.95 ea.
APX-1200	1969-74 SB Left Front.....	17.99 ea.
APX-8100	1968+ BB Right Side.....	15.95 ea.



AX-423 AX-486A

Spark Plug Wire Stands

New OE style reproduction of originals

AX-423	All SB RH.....	14.95 ea.
AX-67R	1967 SB LH.....	26.95 ea.
AX-486A	1968 All SB LH.....	27.95 ea.
AX-486	1969-72 All SB LH.....	27.95 ea.
AX-ZZ	1969 Z/28 LH.....	26.95 ea.
AX-7Z	1970-73 SB LH.....	26.95 ea.



GCS-S4973

Vacuum Advance Cover

This vacuum advance pod cover will give your distributor that show car look. Fits most GM distributors.

GCS-S4973	Chrome.....	3.99 ea.
-----------	-------------	----------



APJ-5240

Ground Strap Kit

Correct braided copper wire and ends complete with OEM screws

APJ-5240	1967-68 3pc.....	19.95 kit
APJ-5230	1969 4pc.....	23.95 set



AJ-850

Timing Covers

New covers complete with crankshaft seal.

AJ-408	1967-76 All Small Block.....	48.95 ea.
AJ-850	1967-72 All Big Block.....	46.95 ea.
BTC-650	Correct Attaching Bolts.....	8.95 kit



ATP-35

Timing Cover Pointers

Correct pointer for adjustment of engine timing

ATP-35	1967-68 SB.....	8.95 ea.
ATP-36	1969-72 SB.....	10.99 ea.
ATP-47	1967-72 SB w/ 7" Bal.....	19.99 ea.
ATP-07	1967-72 BB.....	7.99 ea.



GCS-S9178

Chrome Adjustable Timing Pointers

Provides a convenient way to adjust and verify your engine's ignition timing. Finished brilliant chrome plated steel.

GCS-S9178	SB 7".....	6.39 ea.
GCS-S9179	SB 8".....	6.39 ea.
GCS-S4961	BB 8" Non Adjustable.....	3.19 ea.
GCS-S9180	BB 8".....	3.99 ea.



GCS-S6040C

2 Piece Aluminum Timing Covers

An excellent upgrade for your engine. Rigid sealing surface for positive seal and it looks great, too!

GCS-S6040	SB Polished Billet.....	16.79 ea.
GCS-S6040C	SB Chrome Billet.....	38.39 ea.
GCS-S8422	BB Polished Billet.....	33.59 ea.
GCS-S8422C	BB Chrome Billet.....	50.39 ea.

Note: These covers may not work with some double roller timing chains. Check clearance before starting engine. Doubling of the gaskets or shims may be required to use cover with a short water pump.



GCS-S4935

Chrome Timing Covers

Brilliantly polished timing cover with a rigid sealing surface.

GCS-S4932	SB SWP Chrome.....	16.09 ea.
GCS-S4934	SB LWP Chrome.....	16.79 ea.
GCS-S4935	BB All Chrome.....	16.79 ea.
GCS-S4935R	BB All Unfinished Steel.....	23.99 ea.

Note: These covers may not work with some double roller timing chains. Check clearance before starting engine. Doubling of the gaskets or shims may be required to use cover with a short water pump. SWP = Short water pump. LWP = Long water pump.



GCS-S6042C

SB Billet Timing Cover Pointer

Provides a convenient way to adjust and verify your engine's ignition timing. Adjustable and can be used with 6" or 7" balancers.

GCS-S6041	Billet.....	24.99 ea.
GCS-S6041C	Chrome Plated Billet.....	22.94 ea.
GCS-S6042	Ball Milled.....	28.99 ea.
GCS-S6042C	Ball Milled Chrome.....	24.64 ea.
GCS-S4960	Chrome Plated Steel.....	4.24 ea.



XA-101

BUY'N SAVE
WITH KITS

Valve Cover Kit Big Block

All kits come complete with the following items: (2) valve covers, (2) gaskets, valve cover retainers and TR bolts, (2) V.C. grommets, V.C. oil cap, V.C. elbow and hose and V.C. wire separators.

XA-101	w/o Left Slant.....	130.39 kit
XA-101S	w/ Left Slant*.....	130.39 kit

OE kits with silver gaskets, correct oil cap and Tonawanda decal.

XA-101-OE	w/o Left Slant.....	162.07 kit
XA-101S-OE	w/ Left Slant*.....	162.07 kit

*Use slanted valve covers when brake booster clearance may be an issue.



396TJVC-1



"Turbo Jet" Valve Covers

"Cal Custom" finned aluminum covers feature either the 396 or 427 "Turbo Jet" die cast chrome medallions.

396TJVC-1	All BB 396	229.95 pr.
427TJVC-1	All BB 427	229.95 pr.

2-5/8" - 3" inside clearance. Will work with most roller rockers.



427VC-1



"427" Valve Covers

Like our "YENKO" covers with cast "427" medallions.

427VC-1	Most BB "427"	229.95 pr.
---------	---------------------	------------

2-5/8" - 3" inside clearance. Will work with most roller rockers.



AVC-100



Baldwin-Motion & Yenko Finned Aluminum Valve Covers

We have found these original style "Cal Custom" finned covers commonly used on Yenko, Baldwin Motion, Nickey and other factory super cars.

AVC-100	Most BB.....	179.95 pr.
---------	--------------	------------

2-5/8" - 3" inside clearance. Will work with most roller rockers.

ALS-1065XT



Original Style Chrome Valve Covers

These OE style reproduction covers offer the highest quality chrome plating, correct wire stands and factory oil deflector "drippers". Valve covers are available with a left side slant to increase booster clearance in tight engine compartments. Also available in tall style to fit roller rockers.

ALS-1065	All BB w/o Slant.....	99.95 pr.
ALS-1165	All BB w/ Left Side Slant*	99.95 pr.
ACC-3362	All BB w/o Drippers	38.99 pr.
ACC-3365	All BB w/ Slant w/o Drippers*.....	31.99 pr.
ALS-1065XT	All BB Tall w/o Left Slant w/o Drippers.....	89.95 pr.
ALS-1165XT	All BB Tall w/ Left Slant w/o Drippers*.....	89.95 pr.

*Use slanted valve covers when brake booster clearance may be an issue.



ALS-1165-OJ



Big Block Valve Covers - Chevrolet Orange

This is a pair of brand new big block valve covers painted in Chevy orange. These valve covers are correct for most big blocks and will fit cars with power brakes.

ALS-1165-OJ	All Big Block.....	109.99 pr.
-------------	--------------------	------------



YSCVC-1

“Yenko” Valve Covers

These limited edition “Cal Custom” style finned aluminum covers feature the notorious “YENKO” Red, White and Blue die cast logos.

YSCVC-1 Most BB “YENKO”.....229.95 pr.
2-5/8” - 3” inside clearance. Will work with most roller rockers.



HARRELVC

Dick Harrel Aluminum Valve Covers

“Cal Custom” finned aluminum covers feature the Dick Harrell die cast medallions.

HARRELVC Most BB.....229.95 pr.
2-5/8” - 3” inside clearance. Will work with most roller rockers.



“Motion” Valve Covers

Original style Cal Custom finned valve covers featuring the notorious Baldwin Motion die cast logos.

MOTION-VC Most BB “Motion”.....289.95 pr.
MOTION-VC-BLACK Most BB “Motion” Black179.95 pr.
Note: 2-5/8” - 3” inside clearance.



ATE-4207

Finned Aluminum Valve Covers

OE style reproduction of original GM high performance valve covers.

ATE-4207 SB229.99 pr.
ATE-4207-BLK SB Black229.95 pr.
HVC-28 Flag Decal..... 8.95 ea.



AVC-540

1967 Chevrolet Script Valve Covers

Excellent reproductions of the original stamped “Chevrolet” valve covers in chrome or ready to paint EDP coating. These valve covers feature the correct wire retainers and “O” stamp.

AVC-540 Chrome169.99 pr.
AVC-541 Paintable.....129.99 pr.





AVC-542

1968 SHP Valve Covers

Accurate reproductions of the original 1968 Z/28 or SS350 high performance valve covers in chrome or ready to paint EDP coating.

AVC-542	Chrome	172.99 pr.
AVC-543	Paintable.....	129.99 pr.



GCS-9215B

Black Painted Valve Covers

This is a pair of high quality tall black painted valve covers. A great inexpensive custom touch to any street machine or sleeper!

GCS-9215B	1964-77 SB.....	31.99 pr.
-----------	-----------------	-----------



AT-3666

Small Block Valve Covers

New original style early small block Chevrolet valve covers. These covers come ready to install in correct Chevrolet orange or chrome.

AT-3662	SB Chrome	119.95 pr.
AT-3666	SB Orange.....	99.95 pr.



AFI-9797

Valve Cover Gaskets

AFP-057	All SB.....	13.95 pr.
AFP-059	All BB.....	13.95 pr.
AFI-9797	BB w/ Silver Coating.....	19.95 pr.



APB-1023

Valve Cover Retainers OEM Bolt Kits

Correct steel stamped zinc plated retainers & OEM bolts.

APB-1023	SB TR Bolts 16pc.....	14.95 kit
APB-2023	BB TR Bolts 28pc.....	23.95 kit
APB-1027	SB M Aluminum 8pc.....	16.99 kit



APO-2043



APR-2136

Valve Cover Oil Caps

Choose from either chrome GM replacement, chrome reproduction with correct "S" or black rubber push in cap.

APX-5763	Replacement.....	6.95 ea.
APR-2136	Reproduction "S".....	16.95 ea.
APO-2043	Rubber "OIL"	5.95 ea.



APB-3508



APB-3509



Valve Cover Grommet

Original GM grommets

APB-3508	All SB.....	8.99 pr.
APB-3509	All BB.....	7.95 pr.



APT-3509



APT-3960

Valve Cover Elbows

Correct GM steel valve cover elbows.

APT-3960	All SB.....	12.95 ea.
APT-3509	All BB.....	11.95 ea.



APH-3961



APH-2109



APH-3843

Valve Cover Hose

Correct marked OEM hose which extends from valve cover to air cleaner base. Choose from open or closed element.

APH-3961	All SB Open.....	11.95 ea.
APH-3843	All BB Open.....	4.95 ea.
APH-2109	1970-72 BB Closed.....	12.95 ea.

OIL SYSTEM



Holley LS Swap Oil Pan

GM's popular LS engines are finding their way into a large variety of vehicles. They make great power, plus they're very durable and reliable. Unfortunately, the factory LS pans don't always fit or they hang too low for today's hot rods. Holley's new LS Retro-fit Engine Oil Pan is designed to help! It provides maximum clearance to the chassis and ground, plus provides an OEM fitment for durability and proper sealing.

- Provides OEM fitment- OEM oil filter mounting, OEM oil cooler port provision, OEM engine NVH suppression, OEM flange gasket and sealing, proper structural rigidity and OEM bell-housing attachments.
- Traditional high-quality cast aluminum appearance with clean exterior styling.
- Provides maximum clearance to chassis
- Cast and machined aluminum
- Complete kit including sump baffle, pick-up tube, sump plug, oil filter stud & oil passage cover.
- Fits GM rear wheel drive applications that were originally equipped with a Small Block or Big Block Chevy engine and traditional rear sump oil pan*

HOL-302-2 1967-81 All 349.99 ea.
 Maximum crankshaft stroke = 4.25"
 *Engine location may need to be adjusted (up / down or fore / aft) for cross member or steering linkage clearance depending on the vehicle, steering configuration and chassis type.
 No volume discount.



AEH-999

Oil Pans

Correct OEM oil pans made in North America.

AJ-221	1967-81 SB w/o SHP.....	129.99 ea.
AEH-999	1967-72 All BB.....	199.99 ea.



ACP-15B

Oil Pan Gasket Set

Correct OEM gaskets.

ACP-15B	All SB.....	19.95 ea.
ACP-2BB	All BB.....	16.95 ea.



BOP-2002

Oil Pan Attaching OEM Bolt Kit

Correct "L" head marked bolts for attaching pan to block

- BOP-2001 All SB 18pc..... 9.95 ea.
- BOP-2002 All BB 24pc..... 13.99 ea.



BPO-1988

Oil Drain Bolt / Washer

Original GM

- BPO-1988 All SB/BB 6.95 ea.



AJ-4

Oil Pan Baffle / Windage Tray

Often installed on most High Performance cars this "windage tray" was used to keep oil from splashing the crankshaft. A MUST!

- AJ-4 Small Block 44.99 ea.
- AJ-6 Big Block 23.95 ea.



APC-744

Oil Pan Clip

Correct clip for retaining positive battery cable routing to solenoid

- APC-744 All SB-BB 5.95 ea.



ATE-1576

ATE-1567

Oil Dipstick Kits

Complete with tube and gauge (Stick)

- ATE-1567 1967-79 SB (Green Dot) 31.99 ea.
- ATE-1576 1967-72 BB (Yellow Dot)..... 49.95 ea.



GCS-S6060

Billet Aluminum Engine Dipstick

Show quality dipstick with billet handle. 11.5" length.

- GCS-S6060 Handle 12.79 ea.
- Note: Oil level varies depending on the oil pan used. You may need to mark the dipstick with your own new full level mark.*



GCS-S5002

Billet Engine Dipstick with Braided Tube

Show quality billet aluminum dipstick with braided tube.

- GCS-S5002 1955-79 SB 31.44 ea.
- GCS-S5001 1980-95 SB 31.44 ea.
- GCS-S5003 1965-90 BB 36.54 ea.

Note: Oil level varies depending on the oil pan used. You may need to mark the dipstick with your own new full level mark.



GCS-S4957BA

Chrome / Billet Dipsticks & Tubes

Show quality dipsticks with matching tubes. A great upgrade to any engine compartment!

- GCS-S4957 1955-79 SB, Chrome, 19" 5.39 ea.
- GCS-S4957BA 1955-79 SB, Billet, 19" 8.79 ea.
- GCS-S9420 1980-82 SB, Chrome, 23" 7.99 ea.
- GCS-S9420BA 1980-82 SB, Billet, 23" 12.99 ea.
- GCS-S9231 1983-85 SB, Chrome, 24.5" 7.99 ea.
- GCS-S9231BA 1983-85 SB, Billet, 24.5" 10.99 ea.
- GCS-S4958 1965-90 BB, Chrome, 21" 6.39 ea.
- GCS-S4958BA 1965-90 BB, Billet, 21" 8.79 ea.

Note: Oil level varies depending on the oil pan used. You may need to mark the dipstick with your own new full level mark.



NFX-25

NF-25

Oil Filter

OE style reproduction of early spin on style filter.

- NFX-25 PF-25 AC Filter "White" 24.99 ea.
- NF-25 PF-25F AC Filter "Blue" 9.99 ea.



GAC-110

Oil Pressure Switch

Correct GM switches for cars without gauges.

- GAC-110 All w/o Gauges 11.95 ea.



N-137

N-133

N-142

Oil Pressure Fittings

- N-137 1968+ All SB 6.99 ea.
- N-133 All BB w/o SHP 16.95 ea.
- N-142 All BB w/ SHP 26.95 ea.
- N-234 1967-69 SB 3/4" Tall 14.99 ea.



CHO-3200

Oil Pressure Lines

Correct black plastic line with fittings for most cars with mechanical gauges.

- CHO-3200 Most w/ Gauges 9.99 ea.



NPZ-134

Oil Pressure Line Kit

Correct oil pressure line for console gauges.

- NPZ-134 1967-69 w/ Gauges 29.95 kit



ALG-456

Oil Line Grommet

Correct firewall grommet for oil line.

- ALG-456 1967-69 All 10.95 ea.



AP-2044

Oil Line Bracket

Correct bracket for retaining line to engine.

- AP-2044 1967-69 All 11.95 ea.



KN-HP2002

KN-PS2002



K&N Oil Filters

K&N Performance Oil Filters have been specially designed for professional installers and service providers. Their high flow design can help to improve engine performance by reducing oil filter restriction. Performance Gold Oil Filters have a Premium Wrench-Off design. Oil Filters have become a favorite among consumers for its durability and easy removal. Our Performance Silver Oil Filters have a fluted canister shape so they can be removed with a traditional oil filter wrench commonly available to commercial installers. These Performance oil filters provide outstanding filtration and engine protection throughout their service life. They are engineered to handle all grades of synthetic, conventional and blended motor oils. The pleated media provides high capacity making them suitable for extended oil change intervals when used in accordance with the vehicle and motor oil manufacturers recommendation.

- KN-HP2002 1967-92 Gold Wrench Off 11.99 ea.
- KN-PS2002 1967-92 Silver Standard Fluted 8.99 ea.

No Volume Discount.

STARTERS & RELATED

NO CORE CHARGE



ASM-10A

Starter Motor

We carry original AC Delco USA remanufactured starter motors complete with warranty. No core charge.

ASM-10A	1967-81 SB Auto	113.99 ea.
ASM-10M	1967-81 SB Manual	113.95 ea.
ASM-20A	1967-81 BB Auto	102.95 ea.
ASM-20M	1967-81 BB Manual	102.99 ea.

No Volume Discount. No Core Charge.



TUF-3193NB



TUF-3510A

Tuff Stuff Gear Reduction Starters

These gear reduction starters will allow you to easily crank over your high performance engine. They use less draw than traditional replacement starters and gear reduction allows them to crank over engines with higher compression. These starters will work on both Small Block Chevy and Big Block Chevy Engines using 153 or 168 tooth flywheels. Please be sure to check your flywheel tooth count before ordering.

TUF-6550B	1.6 H.P., 11:1 Compression White Zinc	143.99 ea.
TUF-6550A	1.6 H.P., 11:1 Compression Chrome	183.99 ea.
TUF-6584B	1.9 H.P., 12:1 Compression Black	139.99 ea.
TUF-6772B	2.6 H.P., 18:1 Compression Black	177.99 ea.
TUF-3193NB	3 H.P., 18:1 Compression White Zinc	175.99 ea.
TUF-3510A	1.9 H.P., 18:1 Compression Chrome*	167.99 ea.
TUF-3510B	1.9 H.P., 18:1 Compression Black*	124.99 ea.

*Offset mounting bolts, 168 tooth flywheel only.



TUF-7629



Tuff Stuff Hot Start Remote Solenoid Kit

Give your starter an extra 12 V boost with these hot start kits from Tuff Stuff! This kit is designed to eliminate hot start problems that are common with starter-mounted solenoids. Ideal for GM full-size OEM starters.

TUF-7629	1964-77 All	23.99 kit
----------	-------------------	-----------

No volume discount.



BV-2070



BV-2072



BV-2074

Starter Motor Bolts OEM

Correct "Knurled" bolts for attaching starter motor to block.

BV-2070	SB 3/8-16 x 1 7/8" (Short)	5.99 ea.
BV-2072	BB 3/8-16 x 3 5/8" (Long)	4.99 ea.
BV-2074	3/8-16 x 4 11/16" (X-Long)	5.99 ea.



ATE-4353

Starter Motor Brace

Correct brace for attaching starter to block.

ATE-4353	1967-72 SB w/o 350	11.95 ea.
ATW-2516	1967-72 SB 350	8.95 ea.
ABB-9655	1967-72 All BB	12.99 ea.
APO-516	Attaching Screw	0.50 ea.



APX-1443

Starter Heat Shield

Correct starter heat shield for big block.

APX-1443	All BB	34.95 ea.
GCS-S6077	Satin	14.39 ea.



ALI-1504



A-193

Starter Solenoid Wire Clip

Correct clip for retaining wire harness to solenoid.

ALI-1504	1967 All V8	17.99 ea.
A-193	1968+ All	24.95 ea.

WATER PUMPS & PULLEYS

NO CORE CHARGE



ABR-0898

AC Delco Water Pumps

Brand new AC Delco water pumps.

ABR-0898	1967-68 SB (Short Style)	63.95 ea.
ABR-0918	1967-68 BB (Short Style)	119.99 ea.
ABR-1109	1969-81 SB (Long Style)	65.95 ea.
ABR-1002	1969-72 BB (Long Style)	89.99 ea.

No Core Charge.



TUF-1461N



TUF-1461N



Tuff Stuff Water Pumps

Tuff Stuff water pumps are available in multiple different finishes. Available in standard flow or high flow (Super Cool) version for high power applications. Also available in "Smoothie" version, which features flat top casting with no top water port or plug.

SS= Short Style LS = Long Style

Small Block

TUF-1354NA	1964-71 SS, Chrome	109.99 ea.
TUF-1354N	1964-71 SS, SC, Cast Finish	76.99 ea.
TUF-1354NC	1964-71 SS, SC, Black	88.99 ea.
TUF-1354NB	1964-71 SS, SC, Chrome	117.99 ea.
TUF-1461N	1964-71 SS, Smoothie, Chrome	93.99 ea.
TUF-1449NA	1969+ SS, Chrome	139.99 ea.
TUF-1511NC	1969+ LS, Platinum, Cast Finish	158.99 ea.
TUF-1449N	1969+ LS, SC, Cast Finish	76.99 ea.
TUF-1449NC	1969+ LS, SC, Black	88.99 ea.
TUF-1449NB	1969+ LS, SC, Chrome	156.99 ea.
TUF-1448NC	1969+ LS, SC, Smoothie, Cast Finish	121.99 ea.
TUF-1448NB	1969+ LS, SC, Smoothie, Polished Aluminium	156.99 ea.

Big Block

TUF-1494N	1964-72 SS, Cast Finish	82.99 ea.
TUF-1494NC	1964-72 SS, SC, Black	105.99 ea.
TUF-1494NA	1964-72 SS, SC, Chrome	139.99 ea.
TUF-1461NA	1969+ LS, Chrome	164.99 ea.
TUF-1461N	1969+ LS, SC, Cast Finish	93.99 ea.
TUF-1461NC	1969+ LS, SC, Black	112.99 ea.



Heater Hose / Bypass Nipples

OE style reproduction zinc plated fitting.

AWN-058	5/8" Short	7.95 ea.
AWN-034	3/4" Short	7.95 ea.
AWN-134	3/4" Long w/ AC	8.95 ea.
APN-1060	3/4" Bypass Slotted	7.95 ea.
AWN-1059	1964-67 SB SHP 90°	22.95 ea.

Water Pump Bypass Hose Kits
Correct OEM GM marked bypass hose with correct clamps.

CPH-1637	1967-68 Z/28	12.95 kit
CPH-1658	1967-68 BB (Molded)	12.95 kit
CPH-1672	1969-72 BB (Ribbed)	9.95 kit
CPB-034	1967 BB Clamp	4.95 ea.



Water Pump OEM Attaching Bolt Kits

Correct style attaching bolts with "TR" head markings.

ATR-3232	1967-68 3 Bolts 1 Stud	8.99 kit
ATR-4334	1969-72 All 4 Bolts M Mark	10.99 kit
AWS-301S	Stud Only (Short)	2.99 ea.
AWS-302L	Stud Only (Long)	3.95 ea.



Tuff Stuff Water Pump Bolt Kits

Chrome plated hex head bolts. Includes 4 bolts, 4 flat washers and 4 lock washers.

TUF-7675A	All SB, Short Style	18.99 ea.
TUF-7676A	All BB, Short Style	18.99 ea.
TUF-7678A	All, Long Style	18.99 ea.

Short Water Pump Washer

This washer is for any Chevrolet engine with a short water pump. Since this part can't be seen when the pulley is installed, most people are unaware it exists, but it provides important support for the pulley.



AWW-65	1967-68 All	4.99 ea.
--------	-------------------	----------

*Works on all cars with short water pump.



AWP-656



AWP-949



AWP-796



AWP-1394

Water Pump Pulley

OE style reproduction of original water pump pulleys.

AWP-0245	1967-68 7" 2 Groove Deep	119.95 ea.
AWP-796	1969-81 SB 1 Groove Deep	29.95 ea.
AWP-240	1969-81 SB 1 Groove Deep Z/28	79.99 ea.
AWP-9950	1967-68 All BB 1 Groove Deep	42.95 ea.
AWP-656	1967-68 BB 2 Groove Deep	99.95 ea.
AWP-1394	1969-81 BB 1 Groove Deep	47.99 ea.
AWP-949	1969-81 All 2 Groove Deep w/ AC	99.99 ea.



Billet Water Pump Pulleys

These show quality billet aluminum water pump pulleys will set your show car apart from the crowd. Made of high quality aircraft aluminum.

GCS-S9478	SB, SWP, 1 Groove, Satin	38.99 ea.
GCS-S9478POL	SB, SWP, 1 Groove, Polished	41.99 ea.
GCS-S9600	SB, SWP, 1 Groove, Chrome	16.79 ea.
GCS-S9479	SB, SWP, 2 Groove, Satin	52.99 ea.
GCS-S9479POL	SB, SWP, 2 Groove, Polished	52.99 ea.
GCS-S9601	SB, SWP, 2 Groove, Chrome	16.79 ea.
GCS-S9482	SB, LWP, 1 Groove, Satin	28.79 ea.
GCS-S9482POL	SB, LWP, 1 Groove, Polished	33.59 ea.
GCS-S9604	SB, LWP, 1 Groove, Chrome	16.79 ea.
GCS-S9483	SB, LWP, 2 Groove, Satin	52.99 ea.
GCS-S9483POL	SB, LWP, 2 Groove, Polished	62.99 ea.
GCS-S9605	SB, LWP, 2 Groove, Chrome	16.79 ea.
GCS-S8840	BB, SWP, 1 Groove, Satin	33.59 ea.
GCS-S8840POL	BB, SWP, 1 Groove, Polished	33.59 ea.
GCS-S8842	BB, SWP, 2 Groove, Satin	52.99 ea.
GCS-S8842POL	BB, SWP, 2 Groove, Polished	46.39 ea.
GCS-S9815	BB, SWP, 2 Groove, Chrome	25.59 ea.
GCS-S8844	BB, LWP, 2 Groove, Satin	42.39 ea.
GCS-S8844POL	BB, LWP, 2 Groove, Polished	37.79 ea.
GCS-S9723	BB, LWP, 2 Groove, Chrome	20.79 ea.

Note: SWP = Short Water Pump. LWP = Long Water Pump.

Hardware

GCS-S0005	Bolts	4.99 ea.
-----------	-------------	----------



Crank Pulleys

All pulleys are original GM or the highest quality reproductions on the market. Each pulley is finished in factory semi gloss black like the originals.

ACP-904	1967-68 327/350 1 Groove	39.95 ea.
ACP-833	1967-68 2 Groove Deep	52.95 ea.
ACP-414	1969-81 SB 3 Groove	69.99 ea.
NQ-457	1969-81 350 2 Groove Deep Z/28	79.99 ea.
ACP-203	1964-68 396 1 Groove*	45.95 ea.
ACP-108	1967-68 396/375 2 Groove Deep**	55.95 ea.
ACP-333	1967-68 396/375 3 Groove Deep Cast	199.95 ea.
ACP-404	1969-79 SB 2 Groove	69.95 ea.
AHQ-1396	1969-81 396 2 Groove Deep	89.99 ea.
ACP-330	1969-81 396/454 3 Groove w/ AC	74.95 ea.

*without Power Steering **for all with power steering use with ADP-61



GCS-S8845POL

GCS-S9480

Billet Crank Pulleys

These show quality billet aluminum crank pulleys will set your show car apart from the crowd. Made of high quality aircraft aluminum.

GCS-S9480	SB, SWP, 1 Groove, Satin.....	31.99 ea.
GCS-S9480POL	SB, SWP, 1 Groove, Polished.....	41.99 ea.
GCS-S9602	SB, SWP, 1 Groove, Chrome.....	18.39 ea.
GCS-S9481	SB, SWP, 2 Groove, Satin.....	41.99 ea.
GCS-S9481POL	SB, SWP, 2 Groove, Polished.....	33.59 ea.
GCS-S9603	SB, SWP, 2 Groove, Chrome.....	16.79 ea.
GCS-S8858	SB, SWP, 3 Groove, Satin.....	57.99 ea.
GCS-S8858POL	SB, SWP, 3 Groove, Polished.....	52.99 ea.
GCS-S8963	SB, SWP, 3 Groove, Chrome.....	31.19 ea.
GCS-S9484	SB, LWP, 1 Groove, Satin.....	52.99 ea.
GCS-S9484POL	SB, LWP, 1 Groove, Polished.....	42.39 ea.
GCS-S9606	SB, LWP, 1 Groove, Chrome.....	29.59 ea.
GCS-S9485	SB, LWP, 2 Groove, Satin.....	33.59 ea.
GCS-S9485POL	SB, LWP, 2 Groove, Polished.....	42.39 ea.
GCS-S9607	SB, LWP, 2 Groove, Chrome.....	29.59 ea.
GCS-S9486	SB, LWP, 3 Groove, Satin.....	52.99 ea.
GCS-S9486POL	SB, LWP, 3 Groove, Polished.....	55.99 ea.
GCS-S9608	SB, LWP, 3 Groove, Chrome.....	32.79 ea.
GCS-S8841	BB, SWP, 1 Groove, Satin.....	27.99 ea.
GCS-S8841POL	BB, SWP, 1 Groove, Polished.....	41.99 ea.
GCS-S9817	BB, SWP, 1 Groove, Chrome.....	23.19 ea.
GCS-S8843	BB, SWP, 2 Groove, Satin.....	33.59 ea.
GCS-S8843POL	BB, SWP, 2 Groove, Polished.....	42.39 ea.
GCS-S9816	BB, SWP, 2 Groove, Chrome.....	24.79 ea.
GCS-S8849	BB, SWP, 3 Groove, Satin.....	57.99 ea.
GCS-S8849POL	BB, SWP, 3 Groove, Polished.....	57.99 ea.
GCS-S8845	BB, LWP, 3 Groove, Satin.....	73.99 ea.
GCS-S8845POL	BB, LWP, 3 Groove, Polished.....	73.99 ea.
GCS-S9724	BB, LWP, 3 Groove, Chrome.....	29.59 ea.

Note: SWP = Short Water Pump. LWP = Long Water Pump.



BFC-333

Crank Pulley Bolt OEM

Attaching bolt kit.

BFC-333	All w/ Fine Thread.....	6.95 kit
BRB-100	All w/ Coarse Thread.....	6.95 kit



BPB-5934

Harmonic Balancer Attaching Bolt-Washer

BPB-5933	1964-72 Most SB.....	14.99 kit
BPB-5934	1965-72 All BB.....	13.99 kit

POWER STEERING



Concourse Series "Banjo" Style Power Steering Pumps

These are brand new banjo style power steering pumps with correct reservoir and inlet and outlet fittings. No core charge!

APS-6086	1967-68 All V8.....	175.95 ea.
APS-6153	1969 SB.....	179.95 ea.
APS-6151	1969 BB.....	179.95 ea.
APS-6165	1970-72 All V8*.....	179.95 ea.

*Use with 1970 hose & brackets. No Volume Discounts.

NO CORE CHARGE

APS-6000R

Power Steering Pumps - Replacement

Completely rebuilt second design power steering pumps. These pumps will differ in appearance from our originals, but will fit and function the same. No core charge!

APS-6000R	1969-72 All.....	99.95 ea.
-----------	------------------	-----------

No volume discount



TUF-6183B

TUF-6195A

Tuff Stuff Power Steering Pumps

GM Saginaw style pumps feature all new components: reservoir, pump assembly, cap & dipstick and hardware when it applies. Rated at 1200 psi, rated to work with most gearbox systems.

TUF-6197A	1967-68 SB Chrome Banjo Style.....	235.99 ea.
TUF-6197B	1967-68 SB Black Banjo Style.....	186.99 ea.
TUF-6195A	1969 BB Chrome Banjo Style.....	235.99 ea.
TUF-6195B	1969 BB Black Banjo Style.....	186.99 ea.
TUF-6193A	1970 All Chrome Banjo Style.....	235.99 ea.
TUF-6193B	1970 All Black Banjo Style.....	186.99 ea.
TUF-6183A	1970-74 All Chrome.....	221.99 ea.
TUF-6183B	1970-74 All Black.....	174.99 ea.
TUF-6182A	1975-78 All Chrome.....	221.99 ea.
TUF-6182B	1975-78 All Black.....	174.99 ea.
TUF-6181A	1979 All Chrome.....	221.99 ea.
TUF-6181B	1979 All Black.....	174.99 ea.
TUF-6180A	1980-81 All Chrome.....	221.99 ea.
TUF-6180B	1980-81 All Black.....	174.99 ea.
TUF-6179A	1982-87 All Chrome.....	221.99 ea.
TUF-6179B	1982-87 All Black.....	174.99 ea.
TUF-6184A	1988-92 All Chrome.....	221.99 ea.
TUF-6184B	1988-92 All Black.....	174.99 ea.

No volume discount.



ADR-077

APC-42

Power Steering Pump Cap

Quality replacement power steering pump cap.

ADR-077	1967-81 All Plastic.....	8.95 ea.
APC-42	All OE Style Metal.....	19.95 ea.



GCS-S8848

GCS-S8948

Billet Power Steering Pulleys

These show quality billet power steering pulleys will set your show car apart from the crowd. Made of high quality aircraft aluminum.

GCS-S8848	1 Groove, Satin.....	29.59 ea.
GCS-S8848POL	1 Groove, Polished.....	35.69 ea.
GCS-S8948	1 Groove, Chrome.....	19.99 ea.
GCS-S8847	2 Groove, Satin.....	41.99 ea.
GCS-S8847POL	2 Groove, Polished.....	38.39 ea.
GCS-S8947	2 Groove, Chrome.....	27.19 ea.



ASP-509

Power Steering Pump Pulleys

OE style reproduction power steering pulleys.

ASP-3847	1967-69 1 Groove Deep Cast	
	302, 396/375, 427.....	155.95 ea.
ASP-509	1967-81 1 Groove.....	36.95 ea.
ASP-107	1969-81 2 Groove w/ AC.....	44.99 ea.
ASP-1395	1969-81 1 Groove SHP.....	49.99 ea.
23-28	Pulley Nut.....	3.95 ea.

BUY'N SAVE
WITH KITS



PSKIT-69FBB

Power Steering Conversion Kit

Are you tired of getting a workout every time you want to turn? Ground Up makes it easy to convert to power steering with this power steering conversion kit! We have taken all of the guesswork out of selecting the parts to convert with this all in one solution! Includes: OEM Banjo Style Power Steering Pump, Pump Cap, Brackets, Hardware, Pulley, Pulley Nut, Pressure Hose and Return Hose.

PSKIT-69FSB	1969 SB w/o AC.....	314.06 kit
PSKIT-69FSBAC	1969 SB w/ AC.....	320.50 kit
PSKIT-69FBB	1969 BB w/o AC.....	282.87 kit
PSKIT-69FBBAC	1969 BB w/ AC.....	289.30 kit
PSKIT-702FSB	1970-72 SB w/o AC.....	304.47 kit
PSKIT-702FSBAC	1970-72 SB w/ AC.....	310.90 kit
PSKIT-702FBB	1970-72 BB w/o AC.....	273.28 kit
PSKIT-702FBBAC	1970-72 BB w/ AC.....	279.71 kit



ADP-61

1967-68 396 Driver Pulley

OE style reproduction of the SS396 only power steering driver pulley.

ADP-61	1967-68 BB Driver.....	44.95 ea.
--------	------------------------	-----------



ARK-678F

BUY'N SAVE
WITH KITS

Power Steering Hose Kits

This kit comes with OEM high pressure hose, low pressure return tube, hose and correct clamps

ARK-678F	1967-68 All V8.....	38.17 kit
ARK-69F	1969 All V8.....	39.96 kit
ARK-70F	1970-72 V8.....	39.96 kit

No Volume Discount

Power Steering OEM High Pressure Hose

New correctly bent OEM high pressure hoses with correct fittings.



OEM



CPX-6616

CPX-6616	1967-68 All V8.....	26.95 ea.
----------	---------------------	-----------



CPX-6602

CPX-6602	1969 All V8.....	26.95 ea.
----------	------------------	-----------



CPX-6618

CPX-6618	1970-72 BB.....	26.95 ea.
----------	-----------------	-----------



CPX-277

CPX-263	1970-1972 SB.....	26.95 ea.
---------	-------------------	-----------

CPX-277	1977-79 All V8.....	26.95 ea.
---------	---------------------	-----------

CPX-634	1980-81 All V8 w/ O Rings.....	26.95 ea.
---------	--------------------------------	-----------



NPX-16

Power Steering Return Hose

Complete with correct pre bent flared tube, OEM hose and correct clamps.

NPX-16	1967-76 All V8.....	17.95 kit
CPS-038	OEM Return Hose.....	2.95 per ft
CPN-512	OEM Clamps Screw Type.....	1.95 ea.



ASC-128



AB-31F

Power Steering Hose Retainers

Correct clip for retaining hose to steering box and chassis.

ASC-128	All V8 On Steering Box.....	12.95 ea.
---------	-----------------------------	-----------

AB-31F	1967-69 All V8 On Frame.....	20.95 ea.
--------	------------------------------	-----------

Power Steering Brackets

Original style reproduction and original GM brackets



ASB-7KIT

Big Block Power Steering Bracket Kit

Complete kit with cradle, adjustment brackets and hardware.

ASB-7KIT	1969-81 All BB.....	63.77 kit
----------	---------------------	-----------

Will work on most BB engines with long style pump.
May need some modification.



ASB-9KIT

1969-72 Small Block Power Steering Bracket Kit

Complete kit with all three brackets.

ASB-9KIT	1969-72 SB.....	88.07 kit
----------	-----------------	-----------

Will work on most SB engines with long style pump.
May need some modification.

BUY'N SAVE
WITH KITS



ASB-366

ASB-366	1967-68 SB Cradle.....	49.95 ea.
---------	------------------------	-----------

For use with short water pump.



ASB-383

ASB-383	1967-68 Z/28 / SS350.....	39.95 kit
---------	---------------------------	-----------

For use with short water pump.



ASB-184

ASB-184	1967-68 SS396 Cradle.....	64.99 ea.
---------	---------------------------	-----------

For use with short water pump.



ASB-186 1967-68 396 Adjuster..... 39.99 ea.
For use with short water pump.



AQW-1418 1969 All BB (3 piece).....64.99 kit
Works with original long water pump & P/S pump..



ASB-3941 1969-76 All SB Cradle..... 25.95 ea.
For use with long water pump.



ASB-874 1969-72 SB Rear Support..... 35.95 ea.
For use with long water pump.



AAB-2610 1969-76 SB Adjuster..... 35.95 ea.
For use with long water pump.



ASB-422 1970-72 All BB Cradle 32.95 ea.
For use with long water pump.



ASB-931 1970-81 All BB Adjuster..... 24.95 ea.
For use with long water pump.



Power Steering Hardware Kits

Our kits feature all correct hardware to attach power steering brackets to engine. A MUST!

G-4804	1967 SB 302,350 15.99 kit
G-4805	1967 BB 396 15.99 kit
G-4917	1968 SB 302,350 15.99 kit
G-4918	1968 BB 396 15.99 kit
BSB-69SB	1969-74 SB All 11.99 kit
BSB-1969	1969 All BB 17.99 kit
BSB-1970	1970+ All BB 12.95 kit

BUY'N SAVE WITH KITS



Power Steering Gearbox Kits

Now you can add one of these awesome "close ratio" gear boxes to your conversion. These boxes are original remanufactured GM units and will add the ultimate handling to your ride. Our kit comes with steering box, GM steering coupler (rag joint) and correct attaching bolts. Choose from fast ratio or super fast ratio! No core charge!

1967-69 Camaro		
GBK-1F	3 - 3.5 Fast 290.49 kit
GBK-1SFF	2.5 Super Fast 316.03 kit
1970-76 Camaro		
GBK-1A	3 - 3.5 Fast 298.24 kit
GBK-1SFA	2.5 Super Fast 323.78 kit

No volume discount. Ships UPS Oversize.



Steering Box Bolt

Complete with correct thick washer and bolt.

BSB-757	1967-69 All 3.95 ea.
BSB-759	1970-76 All 6.99 ea.



Pitman Arm

Manual Steering

DA-985	1967-69 75.95 ea.
DA-138Z	1967-69 Z/28 Fast Ratio 169.95 ea.
DA-811	1970-81 89.95 ea.

Power Steering

D-1870	1967-69 69.95 ea.
DA-711	1970-81 109.99 ea.

Pitman Arm Nut

BX-64K	1967-81 6.95 ea.
--------	---------	----------------

ATE-8869A



ATE-8871



ATJ-411



Steering Coupler

Complete joint for connecting column to box. 1967-69 with manual steering features fine spline and 1970-76 with manual steering features coarse spline.

ATE-8869A	1967-69 Manual 49.95 ea.
ATE-8869B	1970-76 Manual 49.95 ea.
ATE-8871	1967-76 Power 49.95 ea.
ATJ-411	1967-76 Bolt All 5.99 ea.

IIS-70F



IIS-78



IIS-78S



Intermediate Steering Shaft

Restore proper steering stability and safety with this newly remanufactured intermediate steering shaft. This shaft goes from the steering column down to the steering box and wears out over time, causing sloppy steering feel.

IIS-70F	1970-76 All 205.95 ea.
IIS-78	1978-92 All w/o Shroud 119.95 ea.
IIS-78S	1978-92 All w/ Shroud 139.95 ea.

NO CORE CHARGE

ARC-12SF

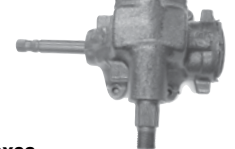

Manual Steering Boxes

Complete remanufactured original Saginaw assemblies. Choose from standard or quick ratio. No core charge.

ARC-12A	1967-69 24:1 Std 289.95 ea.
ARC-12B	1970-76 24:1 Std 289.95 ea.
ARC-12SF	1967-76 16:1 Quick 309.95 ea.

Note: Use ATE-8869B coupler with ARC-12SF.
No volume discount. Ships UPS Oversize.

FPC67ZZSS



THE RIGHT Stuff

Fuel Pump to Carburetor Lines

Correct reproductions of the original fuel lines that run from the fuel pump to the carburetor. Each is CNC bent using original factory blueprints. All lines are available in original steel material (OM) or state of the art show quality stainless steel (SS). All lines are made right here in the USA.

		OM	SS
FPC6702	1967 327/210 2bbl Pre-April.....	19.99 ea.....	25.99 ea.
FPC6703	1967 After April, 1968 All 327/210.....	19.99 ea.....	25.99 ea.
FPC6705	1967-69 350/295, 327/210 5/16".....	19.99 ea.....	25.99 ea.
FPC67ZZ	1967-68 Z/28 4 pc.....	51.99 ea.....	61.99 ea.
FPC6707	1967-69 327/275, 350/295 3/8".....	19.99 ea.....	25.99 ea.
FPC6709	1967-68 396/325.....	19.99 ea.....	25.99 ea.
FPC6901	1969 350 2bbl 5/16".....	19.99 ea.....	25.99 ea.
FPC6902	1969 307, 327 2bbl 5/16".....	19.99 ea.....	25.99 ea.
FPC69XR	1969 Cross Ram, No Block, 3 pc.....	51.99 ea.....	61.99 ea.
FPC69ZZ	1969-72 Z/28 w/ Dual Feed Holley.....	51.99 ea.....	61.99 ea.
FPC7001	1970-72 350/300.....	19.99 ea.....	25.99 ea.
FPC7005	1970 BB Q-Jet.....	19.99 ea.....	25.99 ea.
FPC7203	1971-72 BB Q-Jet.....	36.99 ea.....	50.99 ea.
FPC72ZZ	1972-74 350 4bbl Z/28 Q-Jet.....	21.99 ea.....	27.99 ea.
FPC7801	1978-80 V8 2bbl.....	21.99 ea.....	27.99 ea.
FPC7802	1978-80 V8 4bbl.....	19.99 ea.....	27.99 ea.
FPC8001	1979-81 350 w/ Q-Jet.....	21.99 ea.....	27.99 ea.

Add "SS" to end of part number when ordering stainless.

CPC7007-38

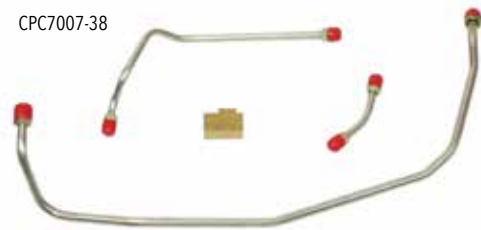

THE RIGHT Stuff

Holley Pump to Carb Lines - New

This fuel pump to carburetor line for use with a new Holley carburetor. OEM carburetors used 5/16 inch inlet nuts, but newer carburetors use 3/8 inch inlet nuts. These lines will improve fuel flow and are designed to be used with these new carburetors.

		OM	SS
APC858	1967-68 BB 8-5/8" Spread.....	48.99 ea.....	58.99 ea.
BPC858	1969 BB 8-5/8" Spread.....	48.99 ea.....	58.99 ea.
BPC938	1969 BB 9-3/8" Spread.....	48.99 ea.....	58.99 ea.
CPC7006-38	1970 BB Short # 747 Pump.....	60.95 ea.....	63.95 ea.
CPC7007-38	1970 BB Long # 768 Pump.....	60.95 ea.....	77.95 ea.
DPC858	1969-72 SB 8-5/8" Spread.....	51.99 ea.....	61.99 ea.
DPC938	1969-72 SB 9-3/8" Spread.....	51.99 ea.....	61.99 ea.

Note: 1970 5/16" lines w/ 3/8" at carb. Add "SS" to end of part number when ordering stainless.

Holley Pump to Carb Lines - Original

Correct reproductions of the original Holley fuel pump to carb lines complete with lines and fuel blocks. These lines are for factory Holleys with 5/16" inlet nuts. These lines will only work on stock engines.

		OM	SS
FPC6775	1967-68 396/375 HP.....	49.99 ea.....	59.99 ea.
FPC6975	1969 396/375 HP.....	49.99 ea.....	59.99 ea.
PCY03	5/16" inlets, 9 3/8" center to center.....	36.99 ea.....	41.99 ea.

Add "SS" to end of part number when ordering stainless.

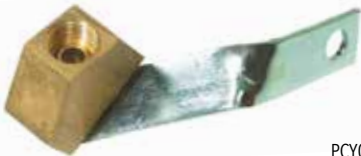

PCY02

Fuel Pump to Carburetor Parts

Correct Y blocks and T blocks for your dual feed Holley carburetor.

PCY01	Y Block w/o Bracket, Brass.....	19.99 ea.
PCY02	Y Block w/ Bracket, Brass.....	28.99 ea.
BPS-7432	Stud for PCY02.....	3.95 ea.
RSBB06	Y Block w/ 3/8" Ports, Used for PCY05.....	24.99 ea.



AHL-516



AHL-38

Carburetor Inlet Fittings

Correct inlet nuts with washers for stock carbs.

AHL-516	5/16".....	12.99 ea.
AHL-38	3/8".....	12.99 ea.



INL-CCF201

Fuel Line Clip Kits

These convenient kits include all of the correct clips needed to install a set of factory fuel lines.

INL-CCF201	1967-68 7pc.....	22.95 kit
INL-CCF202	1969 w/o Return 7pc.....	20.95 kit
INL-CCF203	1969 w/ Return 7pc.....	26.95 kit
INL-CCF205	1970-71 3/8" w/o Return 10pc.....	26.95 kit
INL-CCF206	1970-71 3/8" w/ Return 10pc.....	36.95 kit
INL-CCF207	1972-77 3/8" w/o Return 10pc.....	28.95 kit
INL-CCF208	1972-77 3/8" w/ Return 10pc.....	36.95 kit
INL-CCF209	1978-81 3/8" w/ Return 10pc.....	36.95 kit



AFR-162

1967-68 396 Fuel Line Retainer

Correct fuel line retainer which mounts to the passenger side frame mount on all big blocks.

AFR-162	1967-68 BB.....	10.95 ea.
---------	-----------------	-----------



AFB-239

Z/28 Fuel Line Brace

Correct factory installed brace for carburetor line.

AFB-239	1969-71 Z/28.....	26.99 ea.
---------	-------------------	-----------

AJE-395



ACE-9599

ACE-486



Fuel Pump Hardware

AJE-395	All Activating Rod.....	14.95 ea.
ACE-9599	All SB Plate.....	10.99 ea.
ACE-4867	Fuel Pump Bolts.....	7.95 kit

GCS-S2057



Fuel Pump Block Off Plates

Necessary when using an electric fuel pump.

GCS-S2057	SB, Chrome.....	5.59 ea.
GCS-S2058	BB, Chrome.....	5.59 ea.

ACDelco



AFP-1021

Fuel Pump

Original correct replacement fuel pumps. Brand new AC-Delco units "gold anodized" as original.

AFP-1116	1967-68 327, 350 5/16"	69.95 ea.
AFP-1021	1968-81 All SB 3/8"	41.95 ea.
AFP-1121	1967-81 All BB 3/8"	44.99 ea.
AFP-1124	1968-81 All BB w/ Return	51.95 ea.



AFP-40727

AC Delco Logo Fuel Pump

NOS fuel pump which features the large AC Delco logo. This fuel pump is a must when restoring your car to factory stock.

AFP-40727	1967-72 GM #40727	65.95 ea.
AFP-40503	1967-72 GM #40503	65.95 ea.
AFP-40963	1970-72 GM #40963	65.95 ea.

Note: AFP-40963 has return.



GCS-S2302

Chrome Fuel Pump

Show quality chrome plated fuel pump for all small block. Matching chrome mounting plate with gasket sold separately.

GCS-S2302	SB, Pump	59.99 ea.
GCS-S2310	SB, Plate	6.39 kit

QF-30-350QFT



Quick Fuel Technology Fuel Pumps

For the street cruiser, it's tough to beat the simplicity and reliability of a mechanical fuel pump. Quick Fuel Technology's mechanical pumps flow 110 gallons per hour and utilize lightweight aluminum housings. They feature integrated shutoff valves that are preset at 6.5- to 8 psi, eliminating the need for a separate pressure regulator. For added installation flexibility, the pump casting can be rotated to accommodate various plumbing configurations. 3/8" NPT threads. Gasoline only.

QF-30-350QFT	Small Block	99.99 ea.
QF-30-454QFT	Big Block	107.99 ea.

No volume discount.

Quick Fuel Technology Electric Fuel Pumps

QFT's electric fuel pumps are perfect for combinations that are neither stock nor all out race cars. These pumps flow more than enough fuel to support between 400-750 hp. Mounting hardware and brackets are included.

- 125 GPH Flow Rate
- 14 PSI Maximum Pressure
- Features 3/8" NPT Inlets and Outlets
- Draws 4 Amps or Less at Full Load
- For Carbureted Gasoline Applications Only



QF-30-125-1QFT

QF-30-125-1QFT	Pump Only	114.99 ea.
QF-30-125-1RQFT	Pump/Regulator	131.99 ea.

No volume discount.

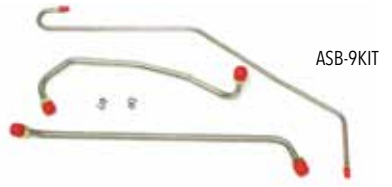

ASB-9KIT

1969 Camaro 350 & 396 3 Piece Line Sets

These unique lines are for use with cars equipped with the GF-432 canister filter and bracket.

		OM	SS
FPC6905	1969 350	36.99 ea.	46.99 ea.
FPC6903	1969 396/325	36.99 ea.	46.99 ea.
FPC6903	1969 396/350	36.99 ea.	36.99 ea.



AXP-3800

Fuel Pump Hose Kit

Correct GM hose for connecting fuel pump to main fuel line. Complete with correct "colored" pinch clamps.

AXP-3800	All 3/8" 3pc	4.95 kit
AXP-1438	All 3/8"-1/4" 6pc	6.95 kit
AXP-6400	All 3/8" 90 Degree Bend 3pc	11.95 kit



ASB-7KIT

GF-432 Fuel Filter & Bracket

This is an OE style reproduction of the original GF-432 fuel filter & bracket for use with 3 piece fuel line. Buy the kit and save!

GF-432K	1969 GF-432 Complete	50.31 kit
AAC-432	1969 GF-432 Filter	39.95 ea.
AFB-234	1969 GF-432 Bracket	15.95 ea.

Holley

Holley Chrome Fuel Pumps

Mechanical pumps designed to work with stock or mildly modified engines.

Free-flow output of 80 GPH (SB) or 80-130 GPH (BB). Body castings can be rotated 360-degrees to ease mounting in difficult places. Heavy duty construction can withstand long periods at high RPM. 1/4" (SB) 3/8" (BB) pipe thread inlet and outlet ports.

HOL-12834	Small Block	91.99 ea.
HOL-12835	Big Block	91.99 ea.

Note: Not compatible with methanol or alcohol. Cannot be used with fuel injection systems.

Holley Electric Fuel Pumps

Holley is proud to introduce the all new Holley Mighty Mite™ electric fuel pumps! They're big on performance, but small in size! They're quiet, easy to install and work with gas, diesel, blended alcohol and E85!

12 volt operation, .25 gal/hr flow, Good for up to 300HP naturally aspirated, Simple 2 wire hookup, Self-priming and regulating.

Quiet operation - 65db, Hose barsbs Fit 5/16" Fuel Hose, Made in the USA

HOL-12-426	All 25 GPH 1.5-4 PSI	49.99 ea.
HOL-12-427	All 32 GPH 4-7 PSI	49.99 ea.

No volume discount.

Holley Fuel Pressure Regulator

Holley fuel pressure regulators are designed to precisely control the fuel pressure from the fuel pump to the carburetor. Too much fuel pressure for a given needle and seat assembly will overload and may cause flooding or drivability problems. Each Holley fuel pressure regulator is fully adjustable so regulating the fuel pressure to your engines needs is simple.

12 volt operation. Preset to 7psi. 3/8" NPT ports (1 in, 1 out, 1 bypass or return). Used in systems with a return line back to the fuel tank

HOL-12-803BP	All Carbureted	87.99 ea.
--------------	----------------------	-----------

No volume discount.

HOL-12-803BP



HOL-12-426



HOL-12834

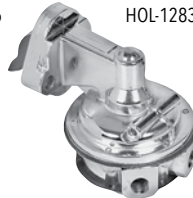

AAC-427



AAC-455

Fuel Filters

Original GM AC Delco

AAC-427	Q-Jet Short Style	4.95 ea.
AAC-455	All Holley Brass	5.99 ea.



GCS-S4297

GCS-S9245

GCS-S9407

GCS-S9177

Chrome Inline Fuel Filters

Choose from a variety of show quality chrome fuel filters to dress up your engine.

Carburetor

GCS-S9407	Bronze Element, 3/8"	8.79 ea.
GCS-S9177	Paper Element, 3/8"	6.39 ea.
GCS-S9245	Glass Element, 3/8"	9.34 ea.

Red Top High Capacity Chrome Fuel Filters

Show quality chrome plated fuel filter with paper element and pipe fittings.

GCS-S4297	Small	33.99 ea.
GCS-S4295	Large	33.99 ea.

NO CORE CHARGE AIT-6961



Alternators

Professionally rebuilt alternator which is proudly made in the USA. Each alternator is 100% tested and rebuilt to exceed OEM specifications.

- AIT-6961 41 Amp External Reg 79.95 ea.
- AIT-6963 55 Amp External Reg 89.95 ea.
- AIT-3342 63 Amp Internal Reg 84.99 ea.

No Volume Discount



TUF-7127D



Tuff Stuff Internally Regulated Alternators

Designed to handle the demand for power needed for today's electronics, Tuff Stuff's high powered internally regulated alternators are perfect if you have added a set of high powered headlights or a high powered stereo system or any other electronic systems to your Camaro. Although meant for 1971 and newer, internally regulated setups can be used on older models that have been converted from external to internally regulated.

- TUF-7127NB 80 Amp, 1 Wire, Chrome 126.99 ea.
- TUF-7127D 100 Amp, 1 Wire, Cast Finish 92.99 ea.
- TUF-7127NF 100 Amp, 1 Wire, Black 126.99 ea.
- TUF-7127ND 100 Amp, 1 Wire, Chrome 126.99 ea.
- TUF-7127NDP 100 Amp, 1 Wire, Polished Alu 126.99 ea.
- TUF-7127NC 100 Amp, 3 Wire, Chrome 109.95 ea.
- TUF-7127K 140 Amp, 1 Wire, Cast Finish 131.99 ea.
- TUF-7127NK 140 Amp, 1 Wire, Chrome 145.99 ea.
- TUF-7139ABULL 100 Amp, Silver Bullet, 1 Wire, Chrome 163.99 ea.
- TUF-7140FBULL 140 Amp, Silver Bullet, 1 Wire, Black 180.99 ea.
- TUF-7140ABULL 140 Amp, Silver Bullet, 1 Wire, Chrome 219.99 ea.

Tuff Stuff Alternator Accessories

- TUF-7500A Chrome Alternator Case Kit 65.99 kit
- TUF-7600A Chrome Fan & Pulley Kit, Single Groove 23.99 kit
- TUF-7600B Chrome Fan & Pulley Kit, Double Groove 26.99 kit
- TUF-7610E Chrome Alternator Pulley, Single Groove 17.99 ea.



APX-1724

Alternator Fan Kit

Correct AC Delco fan zinc plated as original. Comes with special nut.

- APX-1724 All Fan / Nut 15.95 kit



ABN-105



ABB-5790

Alternator Pulleys

- ABB-5799 Standard (2 3/4" OD) 20.95 ea.
- ABB-5790 All w/ SHP (3 1/4" OD) 39.95 ea.
- ABN-105 Correct Retaining Nut 3.99 ea.

GCS-S9487



Billet Alternator Pulleys

Show quality billet alternator pulleys.

- GCS-S9487 1 Groove, Satin 20.79 ea.
- GCS-S9487POL 1 Groove, Polished 25.59 ea.
- GCS-S9447 2 Groove, Chrome 14.39 ea.



AVC-1144

APX-2559

Alternator Pigtail & Boot

Correct plug in "pigtail" for rear of alternator.

- AVC-1144 1967-81 All Pigtail 4.95 ea.
- APX-2559 Rear Alternator Boot 4.95 ea.

GCS-S6679



Alternator Dress Up Kit

This kit is designed to take your stock internally regulated alternator and make it show ready. This kit includes a chrome alternator case, pulley, fan and hardware.

- GCS-S6679 1973-85 GM 35.19 kit

Note: For 1973-85 internal regulated alternators only.



AR-0180

1967-68 Z/28

Alternator Bracket Kit

Correct upper and lower bracket stamped "GT" for all 1967-68 SB.

- AR-0180 1967-68 Z/28 79.95 kit



AA-45KIT

Big Block Alternator Bracket Kit

This is a complete set of alternator brackets and hardware for your Camaro big block with short water pump. This kit works on all cars with short water pumps.

- AA-45KIT 1967-68 BB Short Pump 75.55 kit



KK-301

1969-81 Big Block Alternator Mounting Kit

OE style reproduction of upper-lower brackets, lower mounting stud, lower spacer-brace and upper adjustment bolt w/ special washer

- AKK-301 1969-81 All BB 69.99 kit

Small Block Alternator Brackets

OE style reproduction alternator brackets for your small block Chevy



AAB-3400

- AAB-3400 1967-68 SB Upper 29.95 ea.



AAB-64L

- AAB-64L 1967-68 SB Lower 39.95 ea.

For exhaust manifolds.



AAB-65L

- AAB-65L 1967-68 SB Lower 17.95 ea.

Use with AAB-64L if you have headers.



ACE-5333

- ACE-5333 1969-81 SB Lower 16.95 ea.



ACE-2956

- ACE-2956 1969-81 SB Upper 29.99 ea.

Big Block Alternator Brackets

OE style reproduction alternator brackets for your big block Chevy.



AAB-4500

- AAB-4500 1968 BB Upper 19.95 ea.



ARZ-0027

- ARZ-0027 1968 BB Lower 46.95 ea.



AK-173

- AK-173 1969-72 BB Upper 36.95 ea.











AK-175

- AK-175 1969-72 BB Lower 29.95 ea.

OE Style Chrome Alternator Brackets





These high quality brackets will give your show car that finishing touch!

	GCS-S9315	SB Upper SWP..... 14.99 ea.		GCS-S9637	SB Lower LWP (69-75)..... 5.94 ea.		GCS-S9318	BB Upper LWP (69-92)..... 13.49 ea.
	GCS-S9316	SB Upper LWP (69-75)..... 13.49 ea.		GCS-S9502	BB Lower SWP..... 27.99 ea.		GCS-S9638	BB Lower LWP (69-92)..... 5.94 ea.
	GCS-S9317	SB Upper LWP (76-86)..... 12.79 ea.		GCS-S9581	BB Upper SWP 11.99 ea.		GCS-S9254	Bracket for Headers..... 10.39 ea.

Note: SWP = Short Water Pump. LWP = Long Water Pump.





Custom Style Alternator Brackets

These chrome plated steel alternator brackets will give your engine a unique custom look that will stand out from the crowd.

	GCS-S9319	SB Upper SWP..... 11.99 ea.		GCS-S9320	V8 Upper LWP (69-75)..... 10.39 ea.		GCS-S1637	SB Upper LWP (76-86)..... 15.29 ea.
	GCS-S9321	SB Upper LWP (76-86)..... 12.99 ea.		GCS-S1647	BB Upper LWP (69-92)..... 15.29 ea.			

Alternator Hardware

All of the correct hardware needed to mount your alternator!

	BRB-938	1969-72 SB Lower Bolt..... 4.95 ea.
	BN-339	1969-72 BB Lwr Stud/Nut..... 10.99 ea.
	APX-1138	1969-72 SB Spacer Brace..... 17.99 ea.
	APX-1038	1969-72 BB Spacer/Brace..... 15.95 ea.

	AWB-1114	1964-72 Upper Adjustment Kit..... 5.99 kit
---	----------	--

	ABC-23	1969-72 Bat Cable Clip SB..... 13.95 ea.
---	--------	--

For top of alternator

	ATE-5416	1969-72 Heater Hose Retainer..... 6.99 ea.
---	----------	--

For top of alternator

	BZ-117	1968 BB 396,427..... 15.99 kit
---	--------	--------------------------------

Alternator Mounting Kits

These complete kits make installing your alternator and bracket easy.

G-4828	1967-68 Z/28..... 16.99 kit
G-4645	1967-68 327, 350..... 14.99 kit
G-4766	1967-68 396,427..... 16.99 kit
BZ-117	1968 BB 396,427..... 15.99 kit
G-4962	1969-74 SB All..... 14.99 kit

	AW-506	1964-72 Neg Cable Ground Bolt/Washer..... 0.95 ea.
---	--------	--